

OPERATOR'S MANUAL

■ ALPHA-1500

■ ALPHA-3100

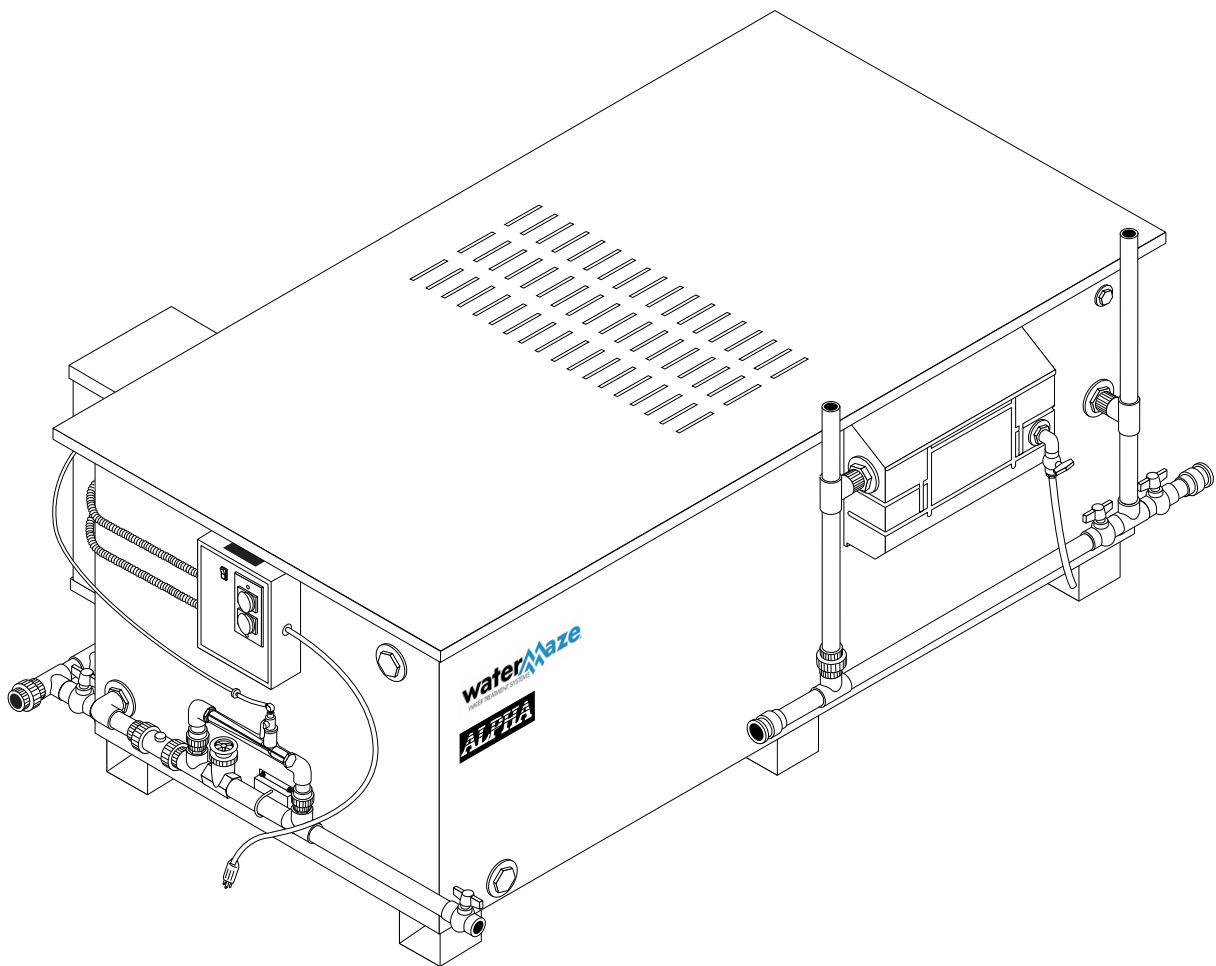

CONTENTS

Introduction	4
Owner/User Responsibility	4
Unpacking	4
Safety Instructions	4-5
General Operating Techniques	5, 10
Installation	6-10
Start-Up	11-12
Operation	12
General Maintenance and Service	12
Chemical Maintenance	13
Owner Chemical Maintenance Program	13
Daily Chemical Maintenance	14
Optional ORP/pH Controller	14-16
Submersible Sump Pumps	17
Pump Safety Information	17
Pre-installation/Sump Pit Info	18
Pump Installation	18
Pump Operation	18
Pump Maintenance	18
Sump Pump Assembly	19
Sump Pump Breakdown & Parts List	20
Peristaltic Metering Pump	21
Ozone Generator Operation	22
Ozone Generator Maintenance	22
Ozone Generator Testing	23
Ozone Generator Breakdown	24
Ozone Generator Parts List	25

CONTENTS

Inlet Side - Alpha-1500 Exploded View and Parts List 26

Inlet Side - Alpha-3100 Exploded View and Parts List 27

Right Side - Alpha-1500 Exploded View and Parts List 28-29

Right Side - Alpha-3100 Exploded View and Parts List 30-31

Discharge Side, Exploded View and Parts List 32

Top View - Alpha 1500 33

Top View - Alpha-3100 34

Troubleshooting 35-36

Preventative Maintenance 37

Specifications 38

Warranty 39

Model Number _____
Serial Number _____
Date of Purchase _____
The model and serial numbers will be found on a decal attached to the Alpha. You should record both serial number and date of purchase and keep in a safe place for future reference.

INTRODUCTION

Your owner's manual has been prepared to provide you with a simple and understandable guide for equipment operation and maintenance, based on the latest product information available at the time of printing. To keep your machine in top running condition, follow the specific maintenance and troubleshooting procedures given in this manual. When ordering parts please specify model and serial number.

This manual should be considered a permanent part of the machine and should remain with the machine if resold.

Owner/User Responsibility:

The owner and/or user must have an understanding of the manufacturer's operating instructions and warnings before using this *WATER MAZE* machine. Warning information should be emphasized and understood. If the operator is not fluent in English, the manufacturer's instructions and warnings shall be read to and discussed with the operator in the operator's native language by the purchaser/owner, making sure that the operator comprehends its contents.

The owner and/or user must study and maintain the manufacturers' instructions for future reference.

NOTE: *WATER MAZE*, Inc. reserves the right to make changes at anytime without incurring any obligations.

This manual should be considered a permanent part of the machine and should remain with it if machine is resold.

When ordering parts, please specify model and serial number.

UNPACKING

1. Alpha module with cover
2. Sump pump in container with float level control
3. Sump pump with 1-1/2" hose x 25' (3.81 cm x 7.62m) long with camlock connections
4. Two 1-1/2" (3.81 cm) ball valves for recycle system
5. 1-1/2" x 16' (3.81 cm x 4.89 m) recycle hose back to pit
6. Ozone Generator
7. Operator's Manual
8. Drain Valve Manifold

Note any damage to machine or components for claims against the freight lines.

SAFETY INSTRUCTIONS

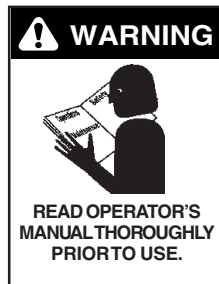

WARNING: To reduce the risk of injury, read operating instructions carefully before using.

1. Read the owner's manual thoroughly. Failure to follow the instructions could cause a malfunction of the machine and result in death, serious injury and/or property damage.



WARNING: Wire the system for correct voltage. See "Electrical" section of this manual and motor nameplate.

WARNING: Follow the wiring instructions in this manual when connecting the system to the power lines.

WARNING: All wiring must be performed by a qualified electrician.

WARNING: Meet the National Electrical Code and local codes for all wiring.

2. The installation of the machine must comply with local and/or national codes.

WARNING: Ground system before connecting to the power supply.

3. This machine, when installed, must be electrically grounded in accordance with local and/or national codes. Do not spray water near electrical components.
4. Never make adjustments on the machine while it is in operation, except for those described in this manual.



5. Do not discharge gasoline or other volatile hydrocarbons into the Alpha. This could cause a gas vapor build-up under the lid which could become an explosive mixture.

6. Before servicing the machine, refer to all the MSDS's on the material identified in the waste stream. You must comply with all warnings and wear all protective clothing as stated on the MSDS's.



7. Protect from freezing and UV light.
8. Protect inlet and outlet hose from vehicle traffic and sharp objects.

9. Be certain couplers on hoses have been locked before operating.
10. Before disconnecting hoses, turn machine off.
11. Inlet water temperature must not exceed 95°F/35°C.
12. When making repairs disconnect machine from electrical source.
13. The best insurance against an accident is precaution and knowledge of the equipment.
14. *WATER MAZE* is not liable for any modifications or the use of components not purchased from *WATER MAZE*.
15. The Alpha and its components will freeze, and must be located in a heated enclosure in cold climates.
16. Running the system without water will damage the pump and may void the warranty.
17. The Alpha should be installed and started up by an authorized *WATER MAZE* dealer.
18. The Alpha and its components must be protected from weather, i.e. wind, rain, direct sun, etc.

GENERAL OPERATING TECHNIQUES

The only operator adjustment to the Alpha is the valve on the inlet to the Alpha. The sump pump supplied with the Alpha will pump about 30 GPM (113.55 L/M). The flow to the Alpha should be 25 GPM (94.63 L/M) or less; therefore, the flow control valve must be slightly closed. The recommended nominal flow rate is 10-15 GPM (37.85 - 56.78 L/M).

INSTALLATION

These machines are designed for indoor use only. Machines must be stored indoors when not in use.

Location

The Alpha must be installed on a level surface, preferably a concrete pad near the wastewater collection sump. In cold climates the Alpha will freeze and should be located in a heated enclosure. The Alpha must be located in a heated enclosure for at least 24 hours prior to start up.

INSTALLATION
FRONT VIEW ALPHA-1500
(INLET END)

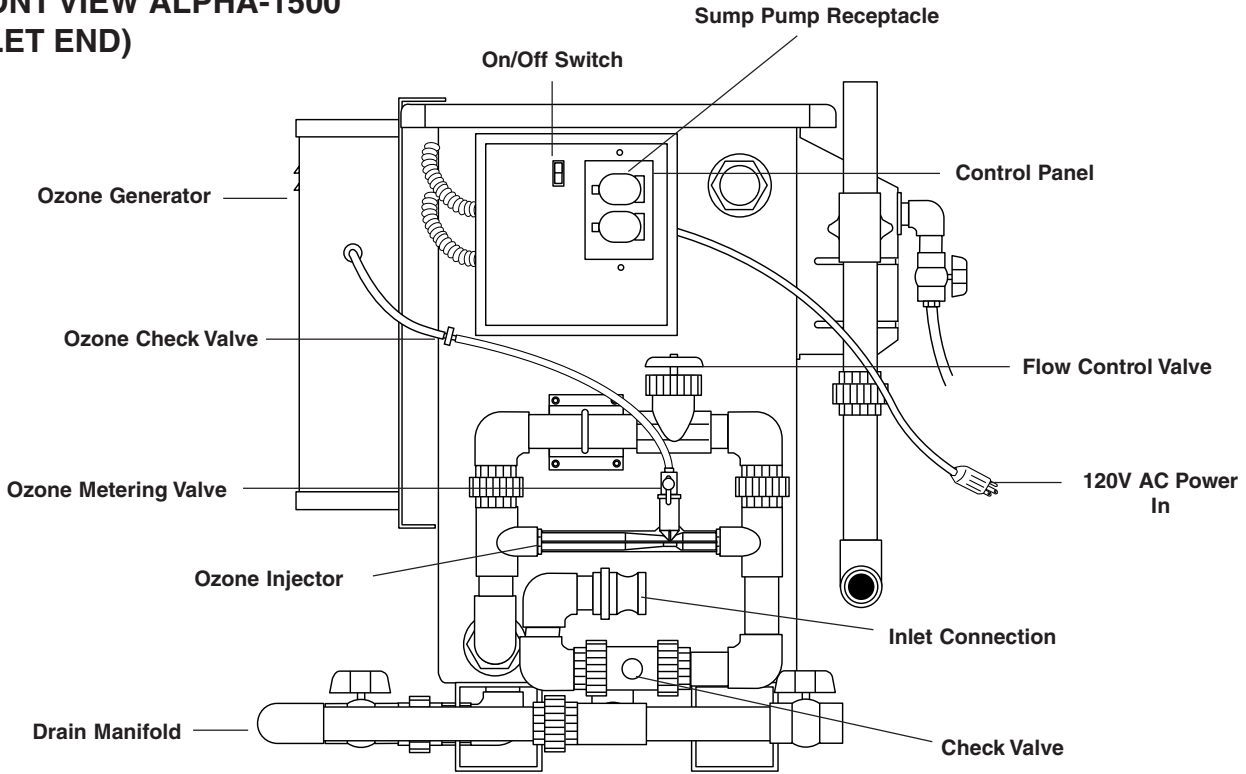

Figure 1

INSTALLATION
FRONT VIEW ALPHA-3100
(INLET END)

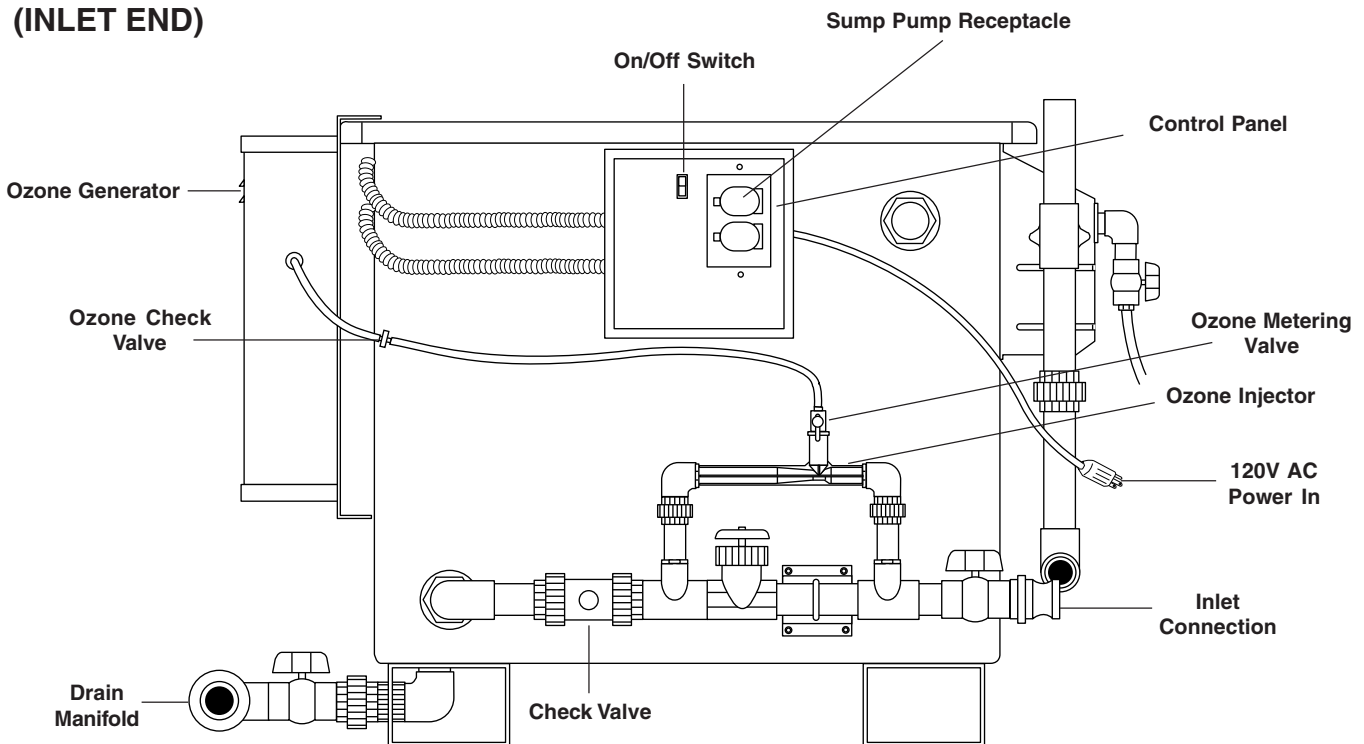

Figure 2

INSTALLATION
SIDE VIEW ALPHA-1500

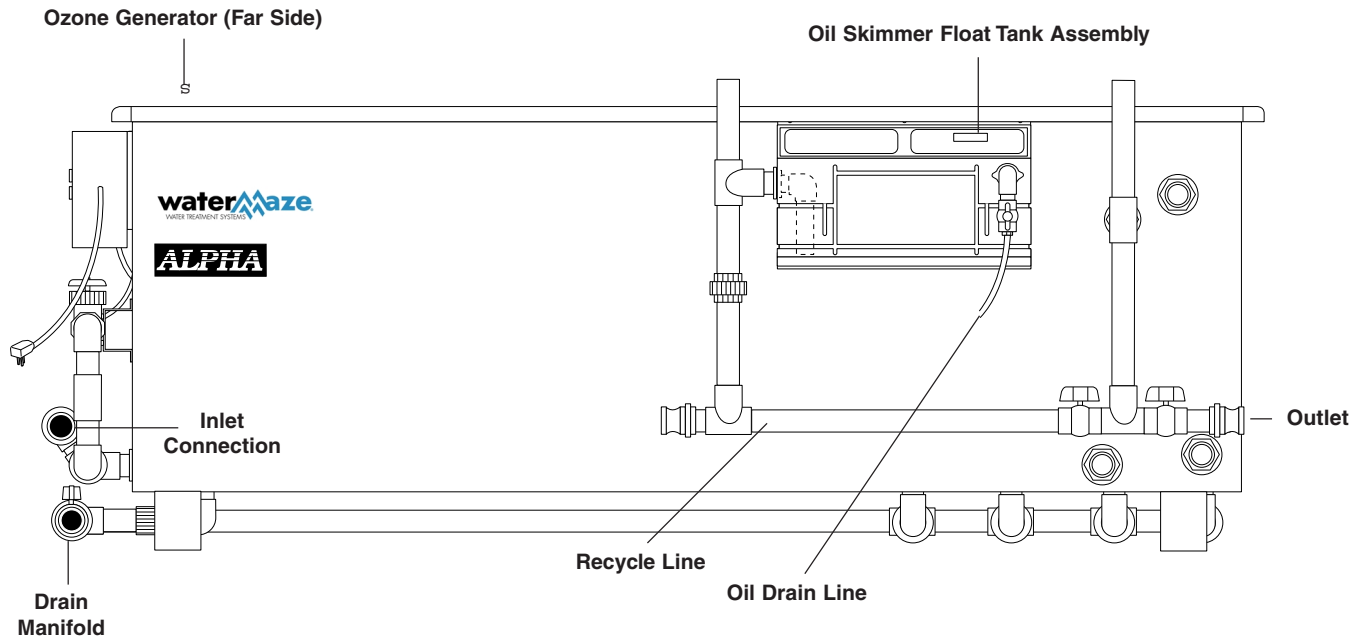

Figure 3

INSTALLATION
SIDE VIEW ALPHA-3100

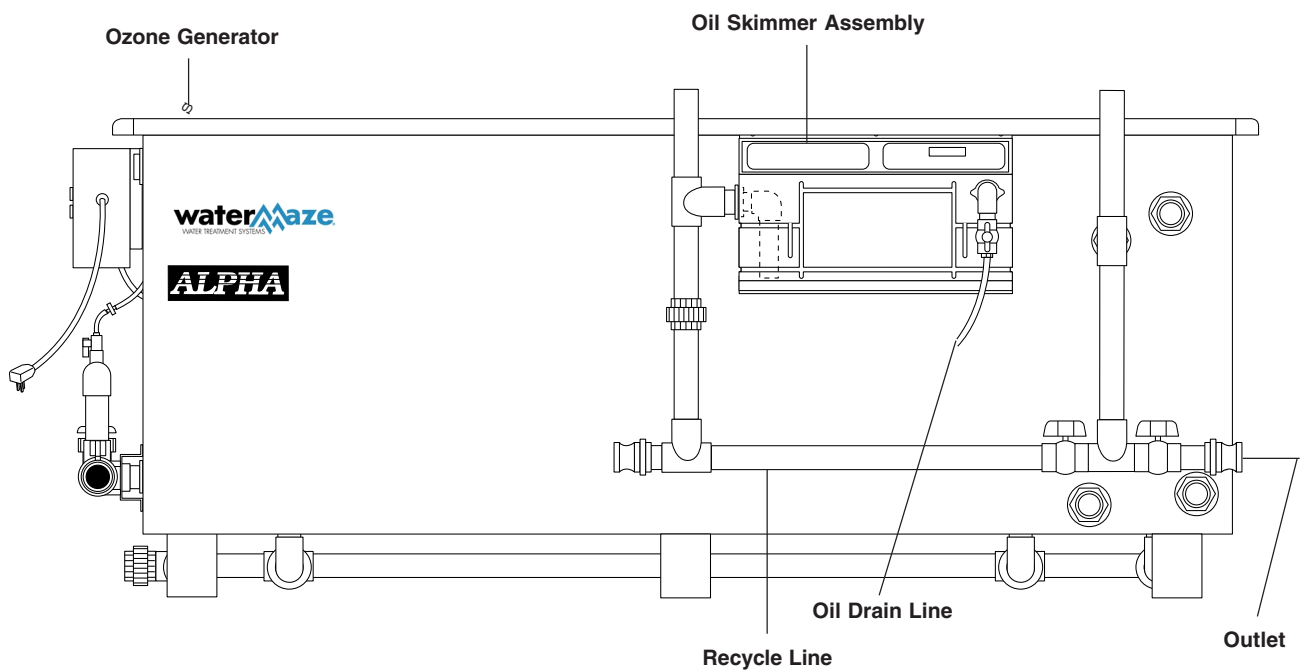

Figure 4

INSTALLATION
TOP VIEW ALPHA-1500

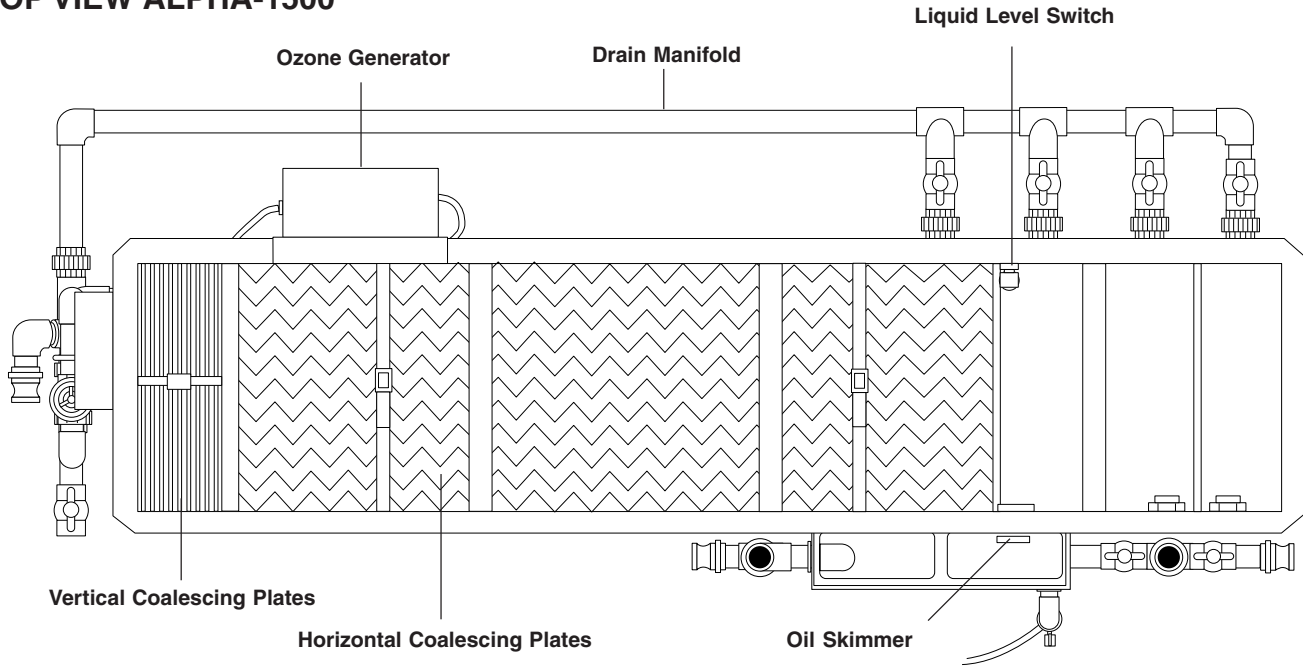

Figure 5

INSTALLATION
TOP VIEW ALPHA-3100

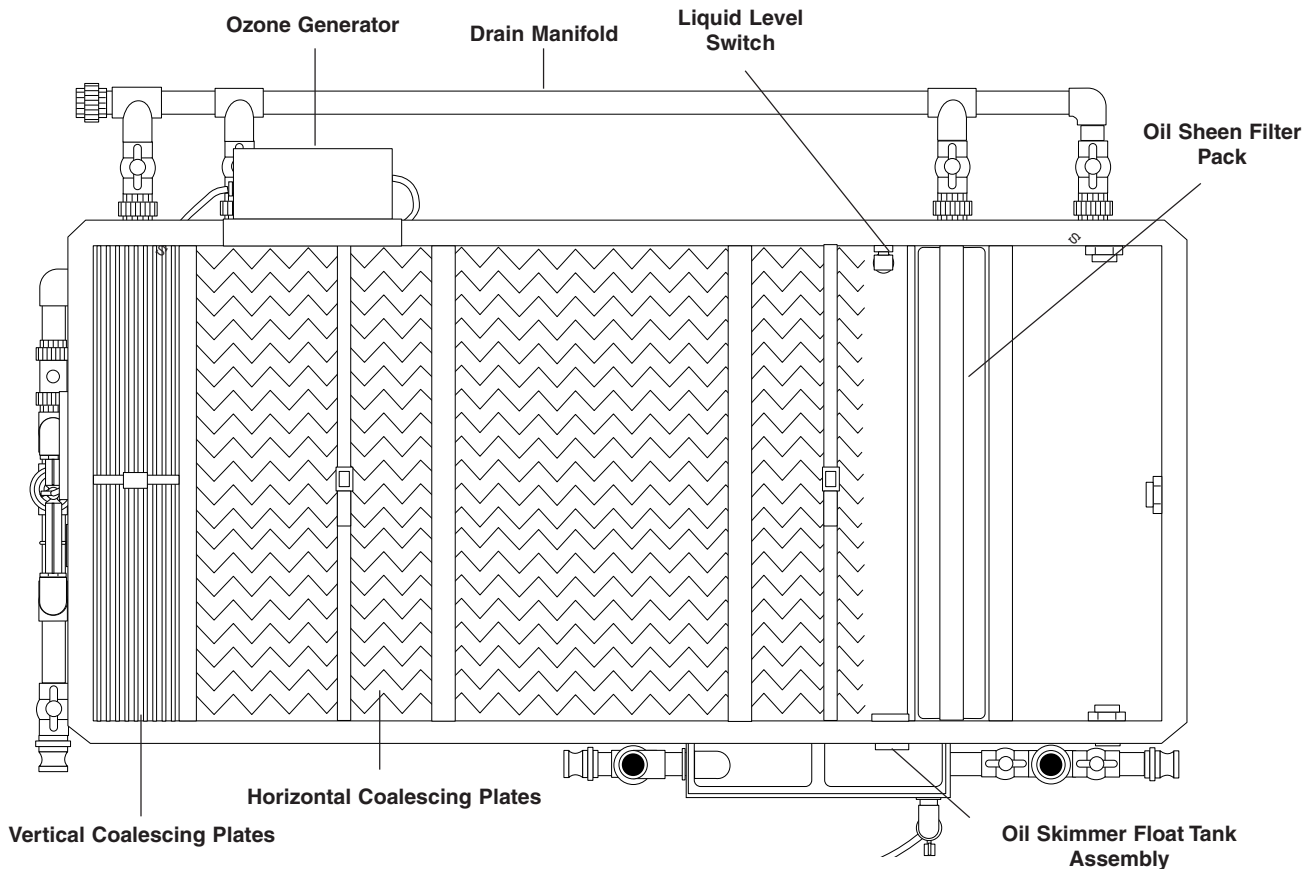

Figure 6

**TYPICAL INSTALLATION ALPHA ONLY
(discharged through sewer system)**

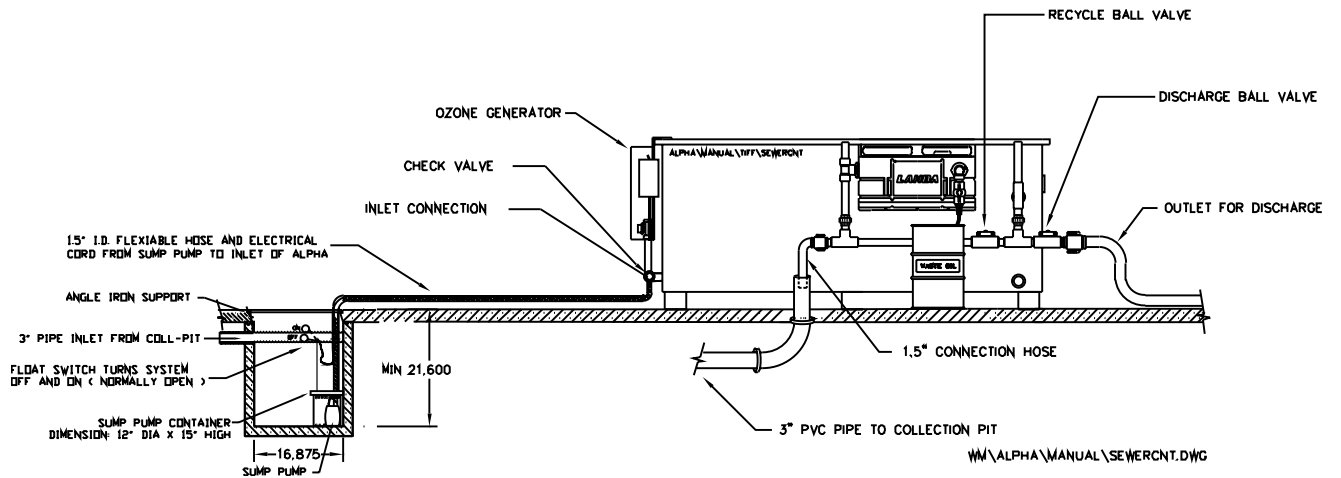

Figure 7

**INSTALLATION
AUTO DISCHARGE OPTION**

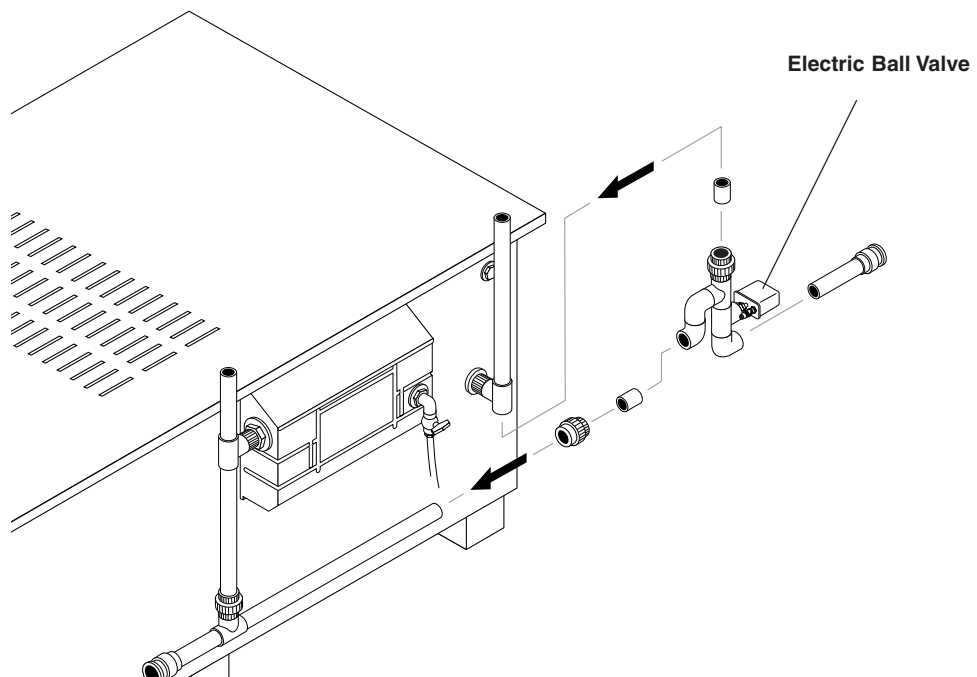

Figure 8

Familiarization With Alpha

The Alpha machine consists of several separate items which must be installed.

- ◆ The most obvious component is a stainless steel separator tank which is the heart of the Alpha. Take a minute to become familiar with this machine.
- ◆ Additional items furnished with the Alpha include:
 - Sump pump with 1-1/2" (3.81 cm) male quick connect coupler and power cord.
 - Perforated sump pump protection/installation container.
 - Sump pump level on/off float control for pump.
 - 1-1/2" x 16' (3.81 cm x 4.89 m) recycle hose.
 - 1-1/2" (3.81 cm) ball valve for recycle system.
 - 1-1/2" x 25' (3.81 cm x 7.62 m) inlet hose with quick connect (cut to length as needed).
 - Drain valve manifold

Leveling Alpha Machine

The Alpha Machine must be set level both side to side and end to end. **This is important** to assure the machine will give you optimum performance.

Sump Pump/Level Control

- ◆ Your Alpha Sump Pump comes in a prepackaged perforated protection container. This container is designed to protect the pump from clogging and damage from debris. There is a level on/off control attached to the pump which plugs into the Alpha and then the pump plugs into the float control on the Alpha only installation.
 - Insert the Level Control Float Tree into the strain relief provided on top of the sump pump container provided.
 - Float tether length must be a minimum of 2" (5.08 cm) long.
 - The turnoff point for the float level control must be 2" (5.08 cm) above the pump container.
 - If you have the optional Auto Discharge Kit, refer to page 20 for proper float location.
 - The float must travel its complete arc without:
 - Water going over top of pit
 - Float touching side walls or bottom
 - Float interfering with electrical wiring, plumbing, bottom or side walls of pit, or any other object.
- ◆ Lower the sump pump container, with pump and float attached, into the sump. Check to assure the float can operate freely.
- ◆ Connect the pump hose to the inlet of the Alpha. This is a quick connect camlock fitting; be sure it is secured.

- ◆ Plug the float into the electrical outlet on the Alpha and then plug the power cord for the pump into the back of the float.
- ◆ Secure the electrical cords of the pump and the float to 1-1/2" (3.81 cm) water hose with nylon tie wraps.

Discharge

Connect the 1-1/2" (3.81 cm) discharge line to the male camlock with the other end into the proper sewer discharge (see Figure 7).

For discharge, close the recycle ball valve. During the night or on weekends and holidays, open the recycle ball valve. Add water to the collection pit until the pump starts.

Connect 1-1/2" (3.81 cm) hose to the recycle port on the Alpha (see Figure 7). The recycle line should be plumbed back to the collection pit so when the Alpha is in the recycle mode, the water in all the pits is circulated to control bacteria.

ORP/pH Controller Option

Install pH/ORP injectors and sensors per drawing on page 28 or 30. Install sensor into pipe so sensor tip is half way into pipe, touching fluid, but not touching bottom of pipe. Follow instructions on page 14 to 15 and instructions that come with controller.

Auto Discharge Option

Tie wrap the N/C and N/O floats to discharge pipe coming off sump pump. Position both floats at the same level towards the upper part of the pit.

Run float wires to electrical box on Alpha and wire according to wire diagrams.

When the water level rises and lifts the floats in the pit, the electric auto discharge valve rotates to discharge water. When the water level drops and floats fall, the electric ball valve rotates and directs water back to the pits.

Electrical

The machine, when installed, must be electrically grounded in accordance with local and/or national codes. Check for proper electrical supply. Plug the cord into a 120V 15 amp electrical outlet. It is recommended that a Ground Fault Circuit Interrupter be installed in the circuit breaker for all Wash-Water equipment.

Note: Always test all electrical outlets for proper voltage before plugging in any equipment.

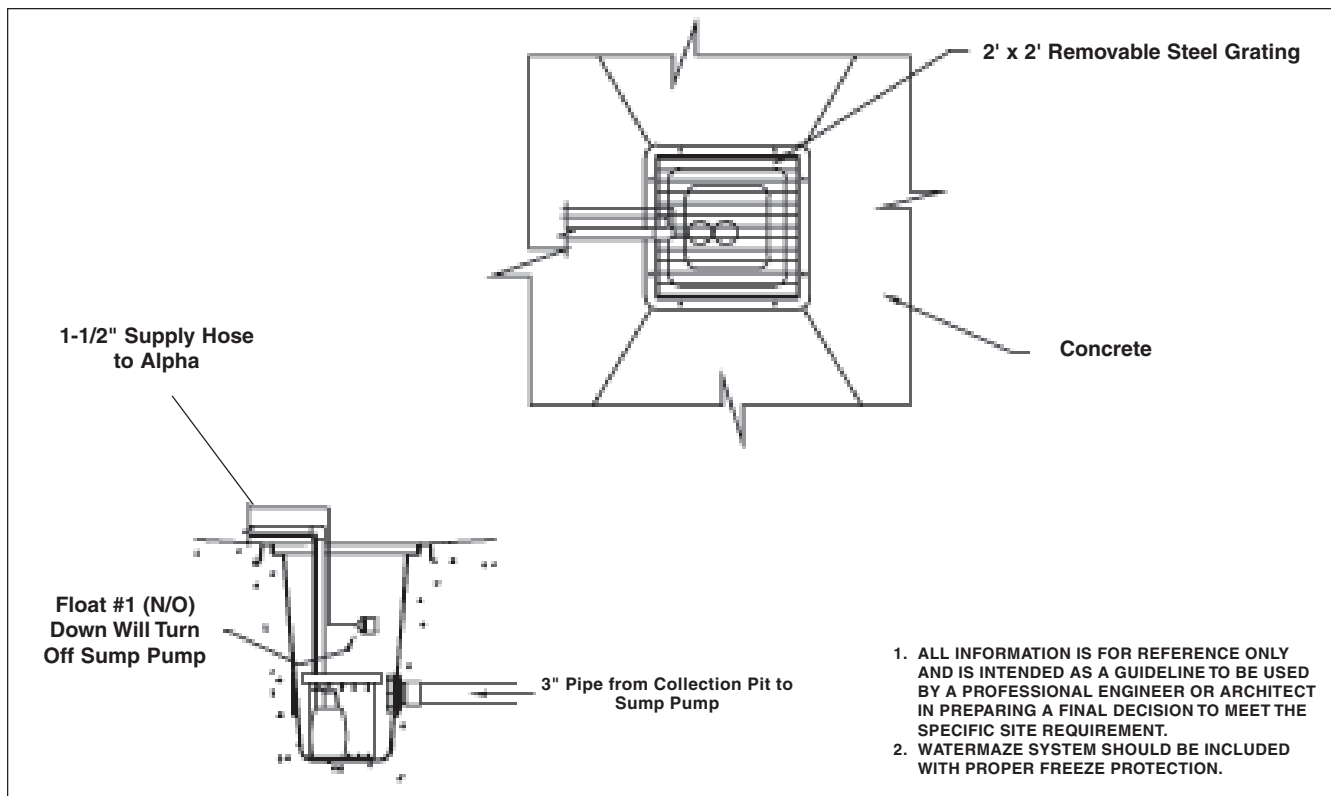

Figure 9

START-UP

Check List Before Starting:

	Yes	No
1. Is Alpha level from side to side and end to end?	___	___
2. Is inlet hose connected to pump and Alpha?	___	___
3. Is outlet hose connected to Alpha and directed to the drain?	___	___
4. Is the voltage correct?	___	___
5. Have the pump and float been connected to the proper outlet on Alpha?	___	___
6. Is the recycle hose attached?	___	___

Start-Up:

- Add water to the sump to activate the float switch.
- Turn the sump pump switch on the Alpha to "ON" (see Figures 1 & 2).
- Adjust the length of the Float Level Control to the desired level.

- Add additional water to the sump (or Alpha directly) until the Alpha is full of water (water is exiting the outlet).
- Adjust the height of the gate inside the Alpha that controls the flow into the oil skimmer. Skim off the oil with a small amount of water. The oil will stay in the oil skimmer while the water returns to the pit through the return line.
- Check the machine for leaks (the machine was hydrostatically tested at the factory but may have been damaged in shipment).
- Check that the machine is level side to side by observing the flow over the baffles. Shut off the inlet valve and gradually reopen it. At low flow rates when the machine is level, flow will be even across the complete top of the baffle.
- Check level, end to end, by observing the water level in relation to the coalescing pack.
- Check the overflow shutoff switch by manually lifting the liquid level switch (see Figures 5 & 6).
- Check the recycle line to make sure the water is flowing back to the collection pit.

Start-Up Check List:

	Yes	No
1. Sump pump plugged into float level control on Alpha?	___	___
2. Sump pump float control working?	___	___
3. High level limit switch working?	___	___
4. Oil skimmer working properly?	___	___
5. Is water in Alpha level?	___	___
6. Recycle system working?	___	___
7. Level control float working?	___	___

OPERATION

After start-up, the only operational adjustment on the Alpha is the inlet flow control valve (see Figures 1 & 2). The sump pump will supply about 30-40 GPM (95 - 114 LPM) of wastewater to the Alpha which exceeds the Alpha's oil/water separation capacity. **Throttle the valve on the Alpha** until the incoming water is the same flow as the recycle water through the recycle line going back to the collection pit.

This will give adequate flow through the ozone injector to meter the ozone generator properly (see Figure 16). If at anytime the incoming flow is adjusted, the ozone generator must be metered again.

GENERAL MAINTENANCE AND SERVICE

Periodic Maintenance

• **Oil Skimmer Collection Tank**

Monitor the level of oil in the oil skimmer. Empty as needed.

• **Solids Removal**

Settled solids are collected in the inlet solids collection chamber. The solids must be removed periodically as dictated by the dirt load coming into the machine. The procedure for removal is as follows.

- Disconnect the machine from the electrical power source.
- **Before opening the drain valve**, be sure the flow of solids is directed to the collection pit. Open each drain valve individually and remove the solids.
- Remove the vertical coalescing pack (see Figures 5 & 6 for location). To remove, lift with the nylon strap that surrounds the coalescing pack.
- After removal of the vertical coalescing pack, hose out the remaining solids in the bottom of the chamber.

- Replace the vertical coalescing pack and close valve. **NOTE:** The vertical coalescing pack can be cleaned, if desired, by washing it with a garden hose or a pressure washer.
- If the solids chamber cannot be drained back to the collection pit, you can use the *WATER MAZE* Pit Cleaner and Sludge Cart for the solids removal on the Alpha 3100. You can use a shop vac for the Alpha 1500.

Service

- Check the electrical cords to assure they are safe, with no damage or cracking.
- Check the inlet and outlet hoses for leaks or damage.
- **Oil Sheen Filter Pack**
The oil sheen filter pack should be removed and the media replaced once a year or as needed (Alpha 3100).
- Remove the filter pack (suitcase like filter, see Figure 6 for location) by removing the retaining bracket and lifting up with the handles on the filter, as shown below.

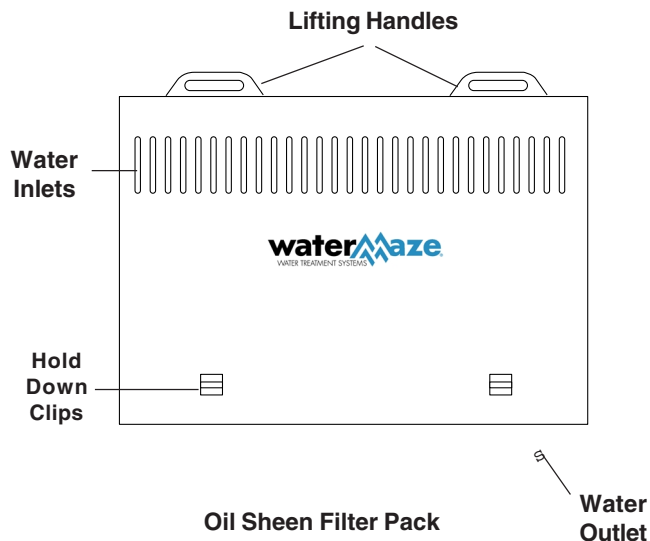

Figure 10

- Slide the filter case back into the Alpha.
 - The slots on top of the case should be facing the inlet.
 - Push the filter firmly down and replace the retaining bracket.

NOTE: If the filter media needs servicing prior to the yearly change out, the filter can be removed and separated. Periodic cleaning of the filter media can be performed by using a hot water pressure washer. **NEVER** clean the filter with detergents as this will cause a deterioration of the media's ability to attract oil and dirt.

CHEMICAL MAINTENANCE PROGRAM

Owner Chemical Maintenance Program to Maintain Water Quality:

Daily monitoring and adjustment of *WATER MAZE* water chemistry is essential. If not monitored and controlled, the recycled water becomes chemically unbalanced, resulting in a host of problems such as algae and bacteria growth, obnoxious odors, iron discoloration and ultimately is unfit for reuse or sewer discharge.

The daily monitoring and adjustment maintenance program, if followed, will provide suitable water. The proper maintenance of the water is not complicated and depends upon a few basic principles:

1. PHYSICAL - effective filtration and recirculation of the water

Effective recirculation of the water through the collection pit, and the Alpha system is achieved only if the system is utilized often (daily 6-8 hours or more) or if the system is set to recirculate the water throughout the total system. *WATER MAZE* has provided controls and procedures to achieve continuous effective water recirculation throughout the process. The Alpha, when operated properly, achieves effective filtration and recirculation.

2. CHEMICAL - proper adjustment of alkalinity and pH

The most important factor to control and maintain is the pH of the water (i.e. the acidity or alkalinity). If the water is acidic (low pH) it will dissolve iron into solution. The presence of iron of more than 0.2 ppm will result in rusty staining of virtually anything the water comes in contact with. Alkaline water can cause cloudiness and greatly reduces the effectiveness of chlorination. Many cleaning detergents are alkaline and will make the water too alkaline. The proper pH range to maintain is 6.8 - 7.2.

Alkalinity refers to the soluble salts in the water. These include bicarbonates, carbonates, hydroxides and other alkali compounds. The water's total alkalinity controls its resistance (buffering ability) to large fluctuations in pH levels.

Another factor which should be monitored for proper water chemistry balancing is calcium hardness. The presence of too much calcium can lead to the formulation of scale.

3. BIOLOGICAL - adequate disinfection, bacteria, and odor control

Chlorination and ozonization are used to control bacteria, and odor formation. For chlorine to be effective, it must be available as free chlorine. If the proper pH and alkalinity is not maintained, or if the water contains dirt

particles, the chlorine will be combined chlorine and not be effective in the control of algae and bacteria growth. Combined chlorine has only 1/15th the strength of free chlorine.

Inadequate or improper addition of chlorine could result in bacteria growth. Once bacterial growth starts, the system must be shock treated. It is best to minimize the chances of bacteria problems.

The killing of bacteria by chlorine exists in two phases:

1. The penetration of the active germicidal principal (hypochlorous acid) into the bacterial cell and
2. The chemical combination of this ingredient with the protoplasm (the complex composition which forms the essential part of plant and animal cells). This combination is directly responsible for the death of the organism.

The activity of this germicidal effect is reduced in alkaline solutions (those with a pH greater than 7.5) and expressed as follows:

pH	% of Effectiveness
4.0	100.0
5.0	99.6
6.0	95.8
7.0	69.7
8.0	18.7
9.0	2.2
10.0	0.2

Hypochlorite when added to solutions with a pH lower than 6.0 can produce oxide which is toxic. In vehicle washing, almost all cleaning compounds are alkaline in nature. Hypochlorite will still control bacterial growth and thus smell at higher alkaline ranges, but as the table indicates, its effectiveness is reduced.

To compensate for this inhibited activity, a larger quantity of hypochlorite is used. This controls bacterial growth, but also increases operational costs.

Typical hypochlorite has a pH of approximately 11.6. This high pH increases the pH of holding tank water, making pH adjustment more difficult.

Trichloro-S-Triazine Trione is a chlorine compound which has a pH of 3.0 and when added to holding tanks aids in the reduction of tank pH levels.

Unlike hypochlorite, which is usually 15 percent chlorine and will produce sodium or calcium salts in holding tanks, these new products are 99 percent chlorine which means that if a solid "puck" of chlorine is used, the total effectiveness of the puck is superior to that of hypochlorite and no negative by-products are produced.

DAILY CHEMICAL MAINTENANCE

Step 1. Collect a water sample from the outlet of the Alpha. **NOTE:** Be sure that the water is circulating from the pit through the Alpha and back to pit.

Step 2. Using the test strips supplied, measure:

- A. The pH.
- B. The residual chlorine (systems with chlorine).
- C. The alkalinity.
- D. The calcium hardness.

Step 3. If the pH is 6.8-7.2 go to Step 4. If not, adjust the pH of the water that is recycled between the Alpha and the pit to pH 6.8-7.2. Muriatic acid or Alum can be used to lower the pH. Soda ash (sodium carbonate) or caustic soda (sodium hydroxide) can be used to raise the pH.

Adjust the pH gradually, allowing complete mixing after adding a chemical. Take a new sample, read the pH and continue to adjust gradually until the desired pH is achieved.

Step 4. The total alkalinity should be between 50-150 ppm. If the total alkalinity is too low, add sodium bicarbonate to raise it. If total alkalinity is too high, add muriatic acid to bring it within acceptable range. This will also decrease the pH. If the pH goes below 6.8, add sodium bicarbonate to increase the pH. This procedure may have to be repeated several times to get the pH and a total alkalinity into the proper range.

Step 5. The calcium hardness should not exceed 25 grains. If it is too high, some water must be removed from the system and fresh makeup water added. Alternatively, an ion exchange water softener may have to be added to the system to reduce and maintain lower calcium hardness levels.

Step 6. (Systems using a chlorinator) Free chlorine levels should be 1-2 ppm and must be maintained by adjusting the flow through the automatic chlorinator, or the regular addition of liquid chlorine. A 10-50% concentrated liquid chlorine is available. Household bleach can be used, but contains only 5% chlorine. Chlorine continually dissipates and becomes used up and the chlorine level must be adjusted daily. Remember, chlorine is most effective when the pH level is correct (7.0).

Initially, extra time is needed to achieve proper water chemistry balance. However, once achieved, it can be easily maintained in a minimum amount of time with daily monitoring and adjustment.

OPTIONAL ORP/PH DIGITAL CONTROLLER - MODEL 250

The Oxidation Reduction Potential (ORP) and pH of the water stream are controlled automatically by the digital controller. The controller receives input from the ORP sensor on the activity of the sanitizer and input from the pH sensor on the pH level of the waste stream. The level of ORP and pH being sensed and the requested levels programmed in the controller will determine if outputs from the controller are sent to the feed pumps. If sanitizer or pH adjustments are needed, the output will turn the corresponding feed pump on. This will inject the required sanitizer or pH until programmed levels are reached and the feed pump will stop.

Acid/Base Jumper

Because most systems are dealing with a high pH situation, the controller is factory set for acid feed. If you require a base feed, turn power off to entire system. Open plastic door on the controller, remove the four screws on display board, carefully pull back board and turn over. Reposition the JP14 jumper to the base position. Return board and door to original position.

Start-Up

Turn switch on right side of controller to the "ON" position. Upon power-up the controller will display "109" and then "ACD" for acid feed or "BSE" for base feed, depending on your requirements.

Feed Mode

The feed mode for the pH and sanitizer can be set to "OFF", MANUAL or AUTOMATIC. Set to Automatic. To select the desired feed mode, press [ORP] or [pH] until the corresponding LED indicator light is illuminated. There is a short delay before activation. **NOTE:** Holding the switch for more than 5 seconds resets the setpoint and calibration for [ORP] or [pH] to original factory values.

ORP Control Setpoint

The ORP setpoint is factory set at 550mV, which is recommended to maintain water quality by killing germs and bacteria. There is no need for ORP calibration.

The sanitizing concentration required to generate a desired ORP value varies with pH and overall water quality, particularly Total Dissolved Solids (TDS) concentration and organic load.

To change the ORP control setpoint:

- Press [SETPOINT].
- Press [ORP]; the display flashes
- Use [UP] and [DOWN] arrows to adjust the ORP value
- Press [SETPOINT] again to save the new value.

pH Calibration

To calibrate the pH, use a reliable, fresh test kit (Phenol Red). Note the value of the pH and compare it to the display value.

To change the pH calibration:

- Press [CALIBRATION]
- Press [pH]; the display flashes
- Use the [UP] and [DOWN] arrows to adjust the pH value
- Press the [CALIBRATION] again to save the new value.

Out-of-Range Alarms

The out-of-range alarms are factory set at 450 and 650mV for ORP and 6.5 to 7.5 for pH. If the ORP is below the low limit, the red LED alarm flashes but the sanitizer feed continues.

If the pH limits are exceeded, the red LED alarm flashes and the pH feeder continues.

To change an alarm limit:

- Press [LOW LIMIT] or [HIGH LIMIT]
- Press [ORP] or [pH]; the display flashes
- Use the [UP] and [DOWN] arrows to adjust the value
- Press [LOW LIMIT] or [HIGH LIMIT] again.

CAUTION: Increasing the out-of-range limits may casue overfeeding of chemicals.

ORP AND PH SENSOR MAINTENANCE

The controller is virtually maintenance free. The enclosure and front panel can be cleaned with a soft cloth moistened with a mild soap and water solution or a glass cleaner. Do not use abrasives or harsh chemicals.

Sensor Cleaning/Testing

The sensor tips must be kept clean and free from chemical deposits and contamination to function properly. After saturation in the waste stream, the sensors may need to be cleaned on a weekly or monthly basis depending on the water quality and other facility-specific characteristics. Slow response and inconsistent readings are indications that the sensors are in need of cleaning.

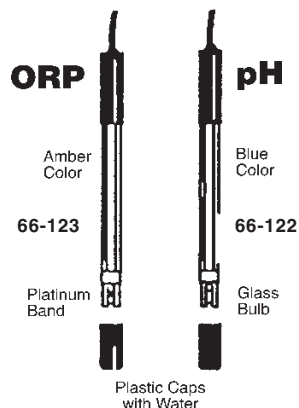

To clean a sensor, carefully remove it from the compression fitting or holding bracket. Clean the tip of the sensor with a mild liquid detergent (Joy, etc) solution. Rinse with fresh water and soak the sensor in a mild acid solution for five minutes. Rinse with fresh water and reinstall the sensor.

To check sensor for proper operation place a small amount of white vinegar, muriatic or hydrochloric acid into a cup and place sensor probe into solution. For the pH sensor, the needle should drop. For the ORP sensor, the needle should rise.

NOTE: Only clean one sensor at a time. Sensors must stay in some kind of liquid at all times.

Sensor Replacement

For preventative maintenance it is also recommended to replace the sensors on an annual basis or as performance diminishes.

Sensor Storage

Extended exposure to atmospheric conditions will cause the sensor tips to dry out. Always remove and properly store the sensors if they are to be winterized or inactive.

Store the sensors with the original cap provided, making sure that each cap is filled with clean water. If the storage containers have been misplaced, store the sensors individually in small glass or plastic containers with clean water covering the sensor tips.

Terminal Block Wiring

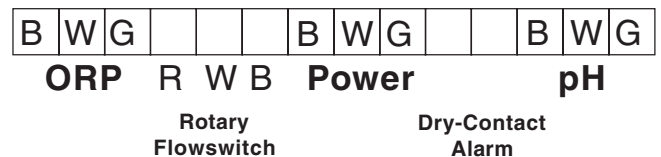

B=black, W=white, G=green, R=red

TROUBLESHOOTING - ORP-pH SENSORS

All controllers are manufactured to the highest quality standards and thoroughly tested before leaving the factory. State-of-the-art designs and fabrication technology should ensure years for trouble-free operation.

PROBLEM	SOLUTION
NO LIGHTS ARE ON WITH POWER ON	Check for power going to controller.
	Check for damaged power connector.
	Check internal fuse (1A slow blo) marked F3 on control board.
ILLOGICAL pH AND ORP VALUE DISPLAYS	The sensor cable connections may be reversed. Verify that the sensor cables are properly connected to their respective BNC connectors on the controller unit.
ORP FEEDER DOES NOT ACTIVATE	Make sure the AUTO feed light for ORP is on.
	Check the ORP setpoint.
	Check ORP relay fuse (5A slow blow) marked F2 on control board.
pH FEEDER DOES NOT ACTIVATE	Verify that the acid/base feed jumper JP14 on the control board is properly set.
	Make sure the AUTO feed light for pH is on.
	Check the pH relay fuse (5A slow blow) marked F2 on control board.
pH REQUIRES FREQUENT CALIBRATION	Clean or replace the sensor as outlined in the maintenance section.
INCONSISTANT OR SLOW pH OR ORP READINGS	Verify that the sensor cables are properly connected to their respective BNC connectors and the controller unit.
	Clean or replace the sensor as outlined in the maintenance section.
	Replace the sensors if needed.
CHEMICAL FEEDER RUNS CONTINUOUSLY	Make sure the AUTO feed mode is selected.
	Verify that the chemical feeders are properly connected to their respective connectors or controller unit.

SUBMERSIBLE SUMP PUMPS

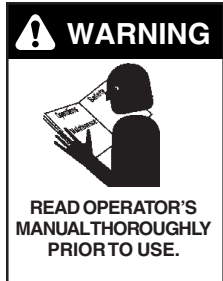

Read instructions carefully before attempting to install, operate, or service the pump. Protect yourself and others by observing all safety information and additional instructions included with this equipment. Failure to comply with instructions could result in personal injury and/or

property damage! Retain instructions for future reference.

PUMP SAFETY INFORMATION

1. Know the pump application, limitations, and potential hazards.

WARNING: Do not use to pump high concentrations of flammable or explosive fluids such as gasoline, fuel oil, kerosene etc. Do not use in explosive atmospheres. Pump should only be used with liquids compatible with pump components materials. Failure to follow this warning can result in personal injury or property damage.

2. Make certain that the power source conforms to the requirements of your PUMP (115 V).
3. Disconnect power before servicing.
4. Release all pressure within the system before servicing any component.
5. Drain all liquids from the system before servicing.
6. Secure all lines before starting the pump. An unsecured line will whip, possibly causing personal injury and/or property damage.
7. Check hoses for weak or worn condition before each use, making certain that all connections are secure.
8. Periodically inspect the pump and system components. Perform routine maintenance as required (see Maintenance).
9. Personal Safety:



- a. Before servicing the machine, refer to all MSDS's on the material identified in the waste stream. You must comply with all warnings and wear all protective clothing stated on the MSDS's.
- b. Keep work area clean, uncluttered and properly lighted — replace all unused equipment.

- c. Keep visitors at a safe distance from work area.
 - d. Make workshop childproof — with padlocks, master switches, and by removing starter keys.
10. When wiring an electrically driven pump, follow all electrical and safety codes, as well as the most recent National Electrical Code (NEC) and the Occupational Safety and Health Act (OSHA).



WARNING: Risk of electric shock.

This equipment is only for use on 115 volt (single phase) and is equipped with an approved 3-prong conductor cord and 3-prong grounding-type plug (as shown in Figures 1 & 2) for your protection against shock hazards. It should be plugged directly into a properly installed and grounded 3-prong grounding-type receptacle. It is recommended that a Ground Fault Circuit Interrupter be installed in the circuit breaker for all Wash Water equipment.

11. All wiring must be performed by a qualified electrician.
12. Make certain that the power source conforms to the requirements of your equipment.
13. Protect the electrical cord from sharp objects, hot surfaces, oil, and chemicals. Avoid kinking the cord. Replace or repair damaged or worn cords immediately.
14. Use wire of adequate size to minimize the voltage drop at the motor.
15. Disconnect power before servicing a motor or its load. If the power disconnected is out-of-sight, lock it in the open position and tag it to prevent unexpected application of power.
16. Do not touch an operating motor. Modern motors are designed to operate at high temperatures.
17. Do not handle a pump or pump motor with wet hands or when standing on a wet or damp surface, or in water.
18. The pump motor is equipped with an automatic resetting thermal protector and may restart unexpectedly. Protector tripping is an indication of motor overloading as a result of operating the pump at low heads (low discharge restriction), excessively high or low voltage, inadequate wiring, incorrect motor connections, or a defective motor or pump.
19. DO NOT run the pump without water. This will damage the pump.

PRE-INSTALLATION SUMP PIT INFORMATION

(For Sump Pit Installation Only)

The sump pump can be installed in a sump pit with a minimum diameter of 18" (45.72 cm) and a depth of 24" (60.96 cm). (Pit dimensions less than these will cause rapid cycling and shortened pump life). It is recommended that the sump pit be no smaller than 2' x 2' x 3' (.61 m x .61 m x .91 m). The sump pit may be constructed of tile, concrete, steel, fiberglass or plastic. Check local codes for approved materials. Make sure there are no small stones, gravel, sand, dirt silt, etc. that may clog or damage the pump and/or pump seal, and cause pump failure. If there are stones or gravel, clean these out before installing the pump. Test pump for proper operation (see Operation) before installing sump pit cover. A sump pit cover will prevent debris from possibly clogging or damaging the pump. It will also prevent persons from falling in and causing injury to themselves. If an existing pit is being used, it must be thoroughly cleaned before installation.

SUMP PUMP INSTALLATION

WARNING: This sump pump is not designed for use in septic tanks or underground vaults to handle raw sewage or effluents. It should never be used in hazardous or explosive locations. Do not use power cord to lift motor. Always use the handle.

1. The sump pump should not be suspended by means of the discharge pipe or power cord. Instead it should be resting on a solid foundation in the bottom of the pit. Clean the sump pit of small stones, gravel, sand, dirt, silt, etc., which could clog or damage pump, pump seal, and cause pump failure.
2. The sump pump is designed for 115 V, 60 HZ operation and requires a circuit of 15 amperes. It is supplied with a 3-wire cord set with a grounding-type plug for use in a 3-wire, grounded outlet. For safety, the pump should always be electrically grounded to a suitable electrical ground such as a grounded water pipe or a properly grounded metallic raceway, or ground wire system.
3. After all piping and controls have been installed, the machine is ready for operation.

PUMP OPERATION

WARNING: Do not touch sump pump, pump motor, water or discharge piping when the pump is connected to electrical power. Do not handle pump or pump motor with wet hands or when standing on wet or damp surface, or in water. Never touch the

sump pump or discharge piping when machine is operating or fails to operate. Always disconnect the pump cord (power) before handling.

1. The shaft seal depends on water for lubrication. Do not operate the pump unless it is submerged in water. Dry running (pump not pumping water) will cause seal damage and eventual pump failure.
2. The motor is equipped with an automatic reset thermal protector. This means if the temperature in the motor should rise unduly, the switch will cut off all power before damage can be done to the motor. When the motor has cooled sufficiently, the switch will reset automatically and restart the motor. If the protector trips repeatedly (cycling on protector) the pump should be removed and checked for the cause of difficulty. Low voltage, long extension cords, clogged impeller, very low head or lift, etc., can cause cycling. Cycling on the protector eventually causes motor burnout.

PUMP MAINTENANCE

WARNING: Before attempting to service, disconnect power from machine. Do not handle pump with wet hands or when standing on wet or damp surfaces or when in water. Failure to follow precaution can result in personal injury and/or property damage.

NOTE: This is a difficult pump to repair, therefore only qualified electricians or servicemen should attempt to repair this machine. Improper repair and/or assembly can cause an electrical shock hazard.

1. Insert a screwdriver through one hole of the strainer until it touches the wear plate and press it downwards (towards the bottom). Repeat procedure until strainer is free and can be removed (Fig. 11).
2. Remove the three screws holding the wear plate and remove the plate (Fig. 12).
3. Loosen and remove the nut on the motor shaft (13 mm). To prevent the impeller from rotating when the nut is loosened, insert a screwdriver between the blades of the impeller and the sand shield in the impeller housing (Fig 13).
Remove impeller. If impeller sticks, use a pair of pliers or two screwdrivers to free impeller from shaft.
4. Clean all parts and flush pump with water through the discharge port to remove possible impurities between the motor and the intermediate chamber. Check the impeller to determine if it is worn or defective. If the wear plate is worn, turn it over so the opposite side points towards the impeller. If the plate has been turned over already, or if it is defective, replace it.

Assemble pump in reverse order of dismantling.

SUMP PUMP ASSEMBLY
MODEL 300 #5-2340

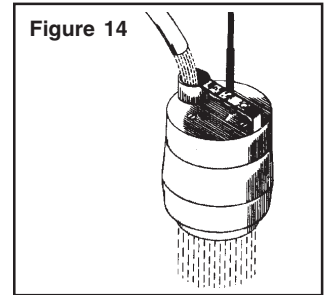
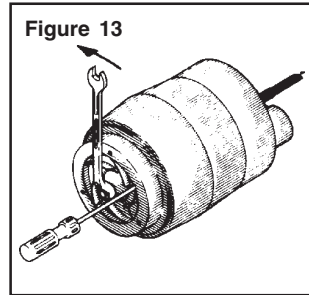
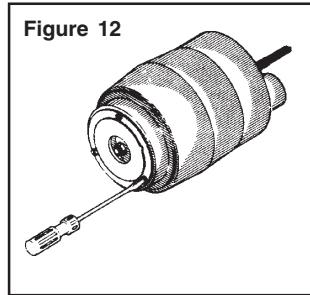
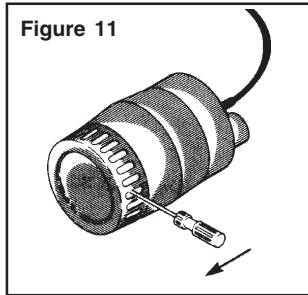

- A. Impeller
- B. Washer
- C. Lock Nut
- D. Wear Plate
- E. Screw

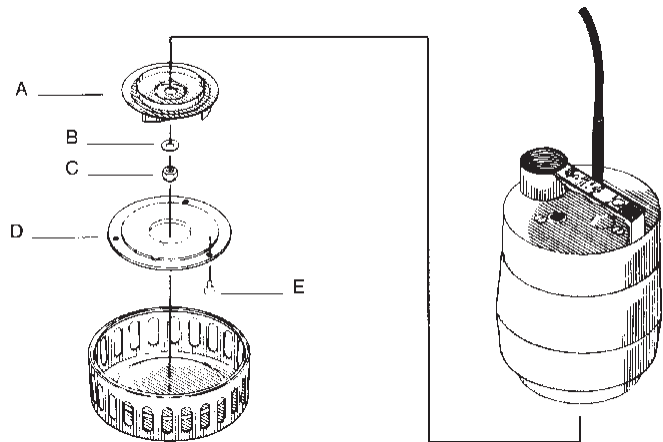

PART

NUMBER	DESCRIPTION
64-015180	Wear Plate Kit
64-015293	Gasket Kit
64-015182	Impeller Kit

Dimensions, Weights & Electrical								
Model	HP	Volts	Phase	Amps	Shipping Weight	Shipping Carton L x W x H	Packing Vol. (Cu. Ft.)	Max. Water Temperature
AP12	1/2 .37 kw	115	1	8	24 lbs.	7-3/4" x 7-3/4" x 12-3/4" 19.69 cm x 19.69 cm x 32.39 cm	0.5	131° F

Performance Table					
Model	5 Ft. 1.52 m	10 Ft. 3.05 m	15 Ft. 4.57 m	20 Ft. 6.10 m	25 Ft. 7.62 m
AP-12	72 gpm	64 gpm	56 gpm	44 gpm	30 gpm

**SUMP PUMP
ASSEMBLY & PARTS LIST**

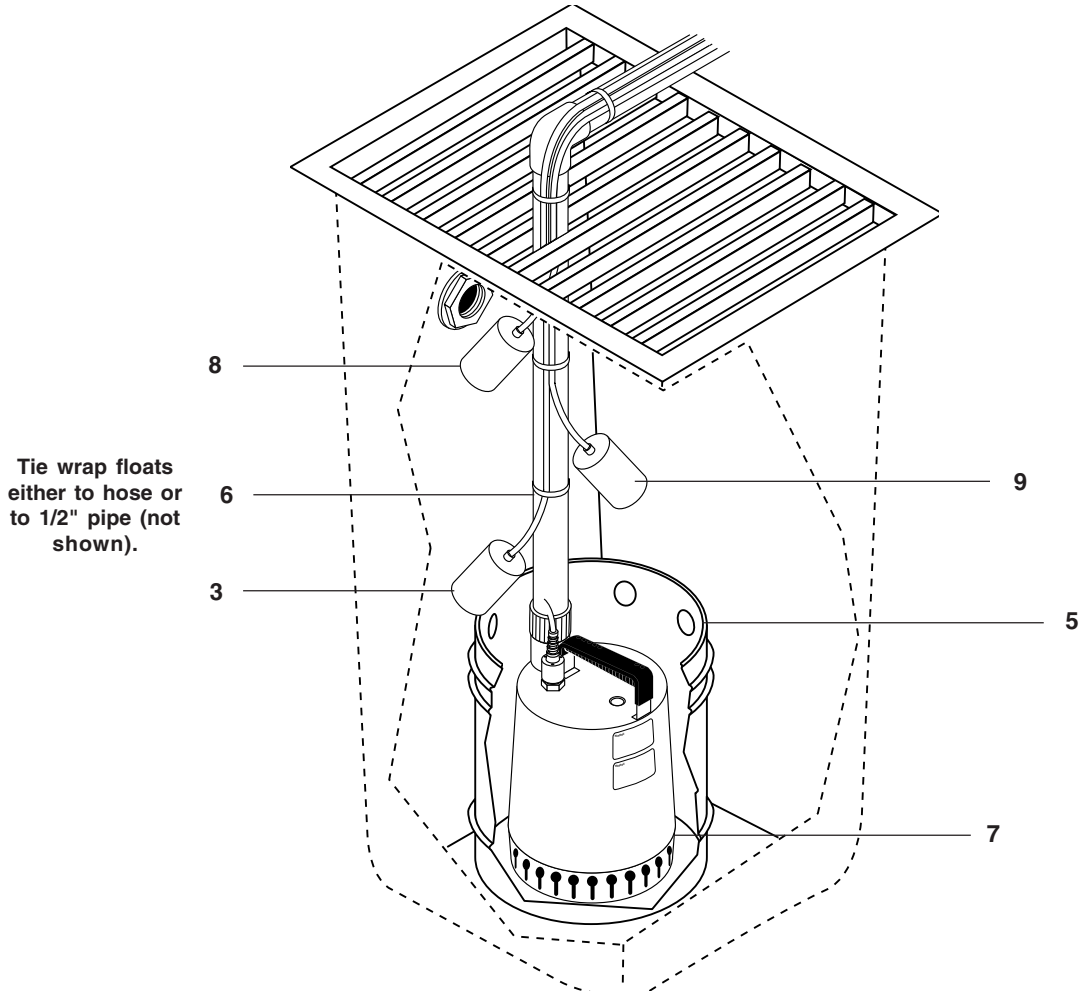

ITEM	PART NO.	DESCRIPTION	QTY
1	2-0100010	▲ Pipe, CPVC S40, 1/2" (1.27 cm) /ft.	3.5
2	2-9027	▲ C-Clamp, Plastic, 5/16" (.79 cm)	2
3	6-02180	Switch, Float, N/O, w/Plug	1
4	4-04080	▲ Lid Only, 6.5 gal., (24.60 L) Reike Sr.	1
5	4-0408	Pail Only, 6.5 gal., (24.60 L) Polly White	1

ITEM	PART NO.	DESCRIPTION	QTY
6	6-05132	Wrap, Ty, 11 Black	5
7	5-2340	Pump, Sump, Automatic 1/2 HP (.37 kw) SS	1
8	6-02177	Switch, Float N/O (optional with auto discharge)	1
9	6-02178	Switch, Float N/C (optional with auto discharge)	1

▲ Not Shown

**SERIES VARIABLE SPEED
PERISTALTIC METERING PUMP MODELS VSP 20
#5-2360 TECHNICAL INFORMATION**

Feed Rate	2.6 - 20 GPD
Tubing Size	7/16" O.D. x 1/4" I.D.
Dimensions	5" H x 6-1/4" W x 7" D
Standard Accessories Included	Head Tubing Injection Fitting with Check Valve Strainer Polyethylene Tubing (1/4 O.D. x 15) Tubing Sleeve (for strainer connection)
Electrical Rating	115V 50/60Hz
Materials:	
Pump Head	Polycarbonate
Pump Head Tubing	Special Synthetic Rubber
Strainer and Injection Point Fitting	PVC
Maximum System Pressure	25 psi (maximum allowed at injection fitting)

INSTALLATION DIAGRAM
Figure 15

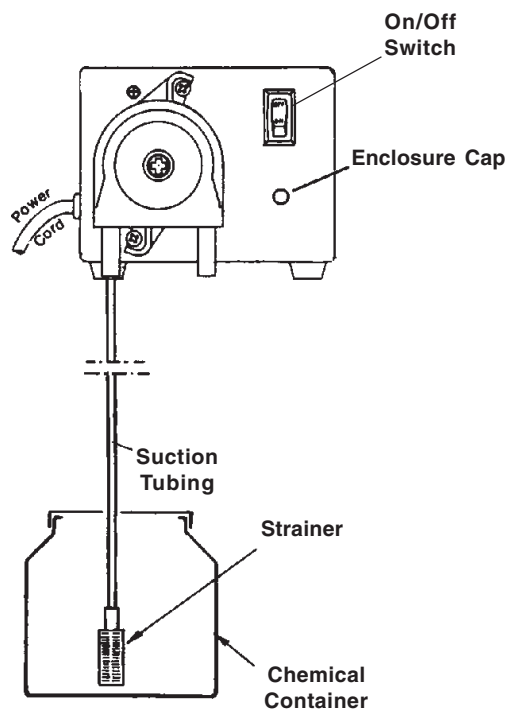

OZONE GENERATOR OPERATION

The indicator light on the Ozone Generator will have a dim green light or no light if the machine is working. It will have a bright green light if the machine has a malfunction.

Setting the Ozone Generator

An SCFH (Standard Cubic Feet per Hour) gauge is used to accurately measure the amount of air flowing through the ozone delivery line, or in other words, the amount of ozone being injected into the water.

1. With the pump running, disconnect the tubing from the ozone check valve and connect the tubing to the bottom fitting on the gauge. This tube is from the ozone generator.
2. While holding the gauge vertically, connect the tubing from the top of the gauge to the ozone injector and read the amount indicated on the gauge. **NOTE:** You are measuring suction, so make sure tubing is attached properly.
3. Begin adjusting metering valve until a 10 SCFH flow for the Series 101 is achieved on the SCFH gauge. **NOTE:** Series 200 is set at 20 SCFH and Series 400 at 40 SCFH. The Alpha machine comes with series 101 standards.
4. Reconnect tubing to the ozone check valve.

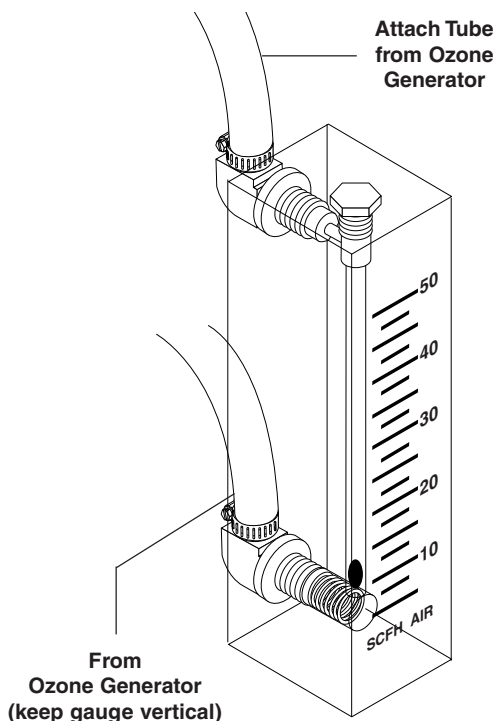

Figure 16

OZONE GENERATOR MAINTENANCE

CAUTION: Never look at the unshielded ozone lamp while operating the machine. This lamp can cause severe eye and skin damage. There is a green indicator light that will turn bright green if there is a problem. It will be OFF to DIM under normal running conditions.

Lamp:

The lamp has a 9,000 hour life expectancy.

Testing the Lamp:

To test the ozone lamp use a voltmeter set on ohms. First remove the ozone cover and unplug the lamp plug from the ozone lamp. **NOTE:** There are two filaments, an upper and a lower, inside the lamp. Place one of the voltmeter leads on one of the lamp prongs and with the other lead, touch all of the three remaining prongs. If continuity is not achieved, replace the ozone lamp (Part #6-0534). You should get continuity from two prongs for the upper filament and from the other two prongs for the lower filament (see diagram on page 24).

To test the ballast, use a voltmeter set on the correct voltage (120V or 240V). Place one of the voltmeter leads into the lamp plug where the white wire goes into it and plug the other voltmeter lead into the lamp plug where the blue wire goes into it. If no voltage is present, replace the ballast (Part #6-05231 - 120V, Part #6-05232 - 240V). If the lamp has continuity and the voltage is good on the ballast but the lamp still will not come on, there is a problem with the starter inside the ballast and the ballast must be replaced.

Replacing the Lamp:

Replacement lamps are available from your Water Maze Dealer should one be needed. Simply turn off the power, remove the two screws on the power pack cover and remove the cover. Disconnect the plug on the end of the ozone lamp. Now, loosen the lamp holder locking ring from around the end of the lamp by turning it counter clockwise and remove it. Remove the lamp by grabbing the rubber bushing around the end of the lamp and pulling it straight out. Remove the rubber bushing from the lamp and install it on your new lamp, making sure the outer edge of the bushing is flush with the outer edge of the silver end cap on the lamp. Now, slide the lamp back into the reaction chamber. The lamp holder may now be reinstalled and tightened. Reinstall the plug onto the lamp and replace the pack cover.

Caution: Keep the lamp free of fingerprints and dust particles. Handle only the metal end caps. You can clean the lamp with rubbing alcohol and a soft cloth. A dirty lamp will not allow maximum ozone output.

OZONE GENERATOR TESTING

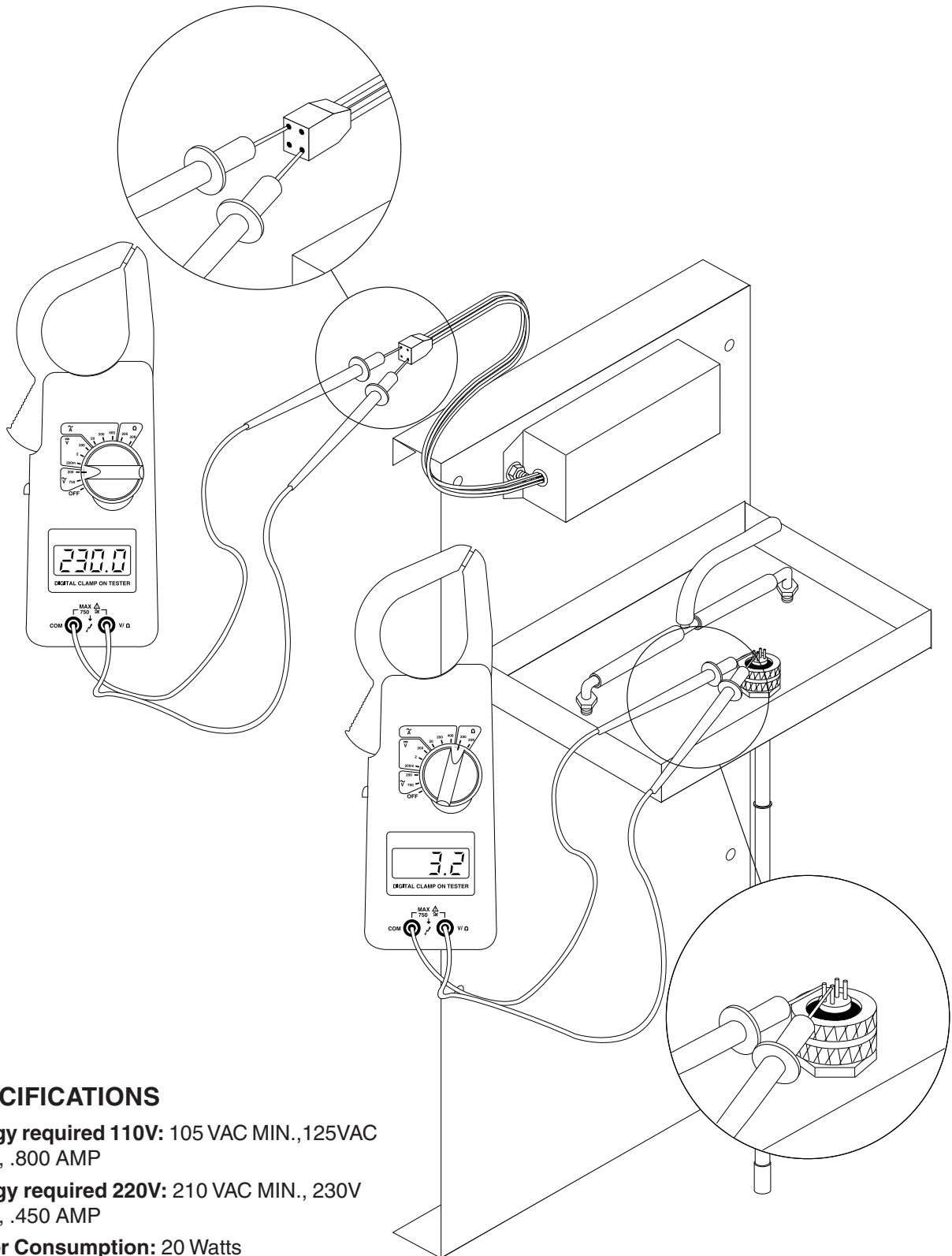

SPECIFICATIONS

Energy required 110V: 105 VAC MIN., 125VAC MAX., .800 AMP

Energy required 220V: 210 VAC MIN., 230V MAX., .450 AMP

Power Consumption: 20 Watts

Average Lamp Life: 9,000 Hours

Lamp Wavelength: 185 nm

Dimensions: 10½" x 23½" x 8" (26.67 cm x 59.69 cm x 20.32 cm)

OZONE GENERATOR
PARTS BREAKDOWN

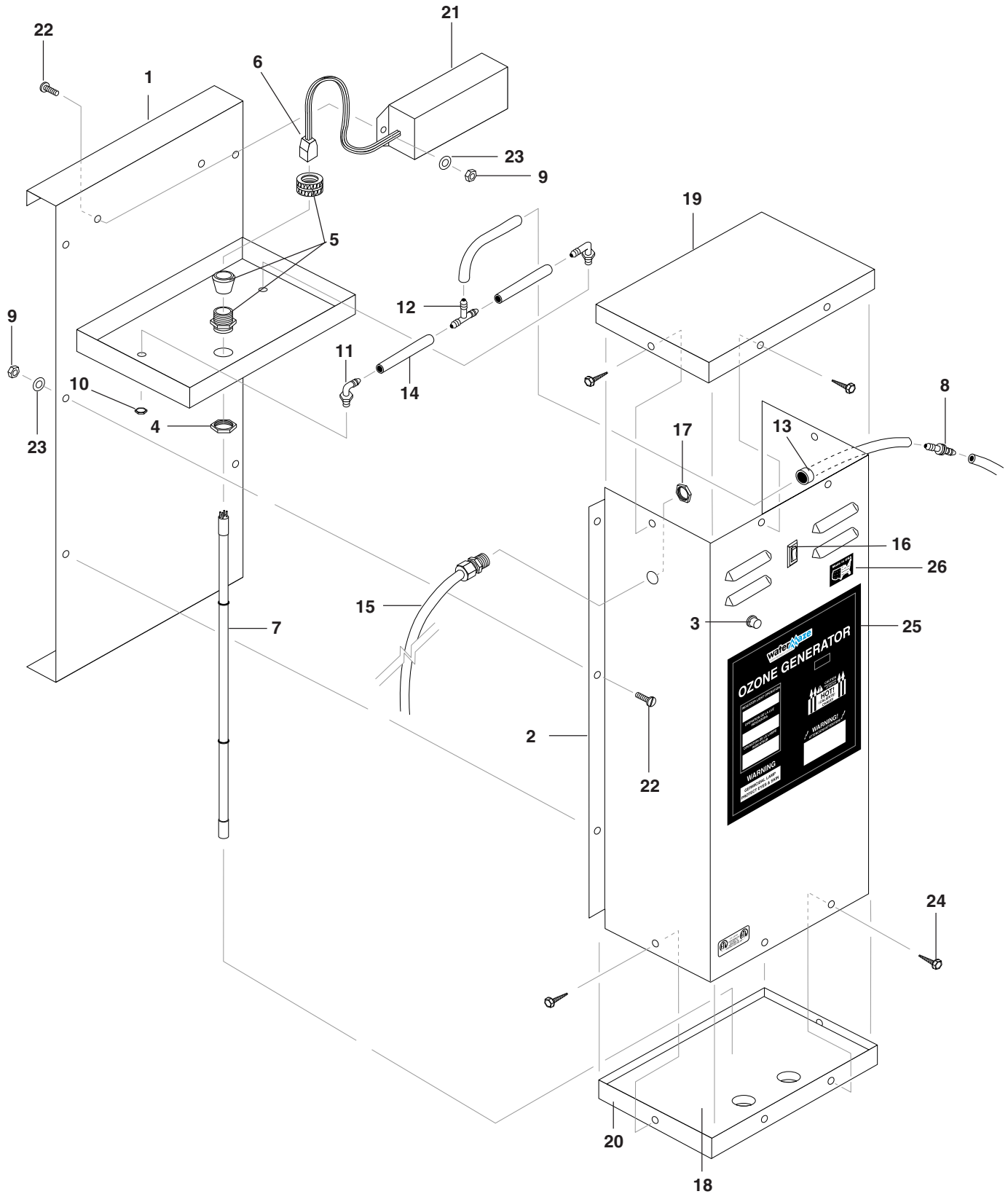

**OZONE GENERATOR • SERIES 101
PARTS LIST**

ITEM	PART NO.	DESCRIPTION	QTY
1	95-0750018	Ozone Box, Back, 101, 200	1
2	95-0750019	Ozone Box, Front, 101, 200	1
3	6-020530	Light, Indicator, Green, 125V	1
4	6-05172	Locknut, 3/4" (19.05 mm) Conduit	1
5	6-05220	Connector, Aluminum Cord SCH1037	1
6	6-05233	Connector, 4 Pin Plug	1
7	6-0534	Lamp, Ozone Replacement	1
8	2-307	Ozone Check Valve	1
9	17-22282	Nut, 10/32" (7.94 mm) NF ST ST KEP	12
10	2-0110	Locknut, 3/8" (9.53 mm) Nylon	2
11	2-01112	Connector, 3/8" x 3/8" (9.53 mm x 9.53 mm), Male Elbow (Kynar)	2
12	2-01133	Tee, 3/8" (9.53 mm) (Kynar)	1
13	2-0141	Bushing, 1/2" (12.7 mm) Snap	1
14	4-02080002	Tubing, 3/8" x 1/2" (9.53 mm x 12.7 mm) Clear Vinyl	6
15	6-0101	Cord, Service, SEO, 16/3 (30.48)	8 ft.

ITEM	PART NO.	DESCRIPTION	QTY
16	6-020251	Switch, Curvette 120V & 220V	1
17	6-05153	Strain Relief, 1/2" (12.7 mm) NPT Ozone Gen	1
18	2-01044	Cushion, 1/2" x 8-3/4" x 5-3/4", (12.7 mm x 22.23 cm x 14.61 cm) 101, 200	1
19	95-07500181	Ozone Box , Top, 101, 200	1
20	95-07500182	Ozone Box, Bottom, 101, 200	1
21	6-05231	Ballast, 120V, Ozone Generator	1
22	90-10001	Screw, 10/32" x 1/2" (7.94 mm x 12.7 mm) Slot Pan MS ZN	12
23	90-400012	Washer, 10 x SAE ZN	12
24	90-2999	Screw, #10 x 1/2" (12.7 mm) Tek Hex Head	8
25	10-3018	Label, Ozone Generator Operating Instructions	1

INLET SIDE (Front)

ALPHA-1500

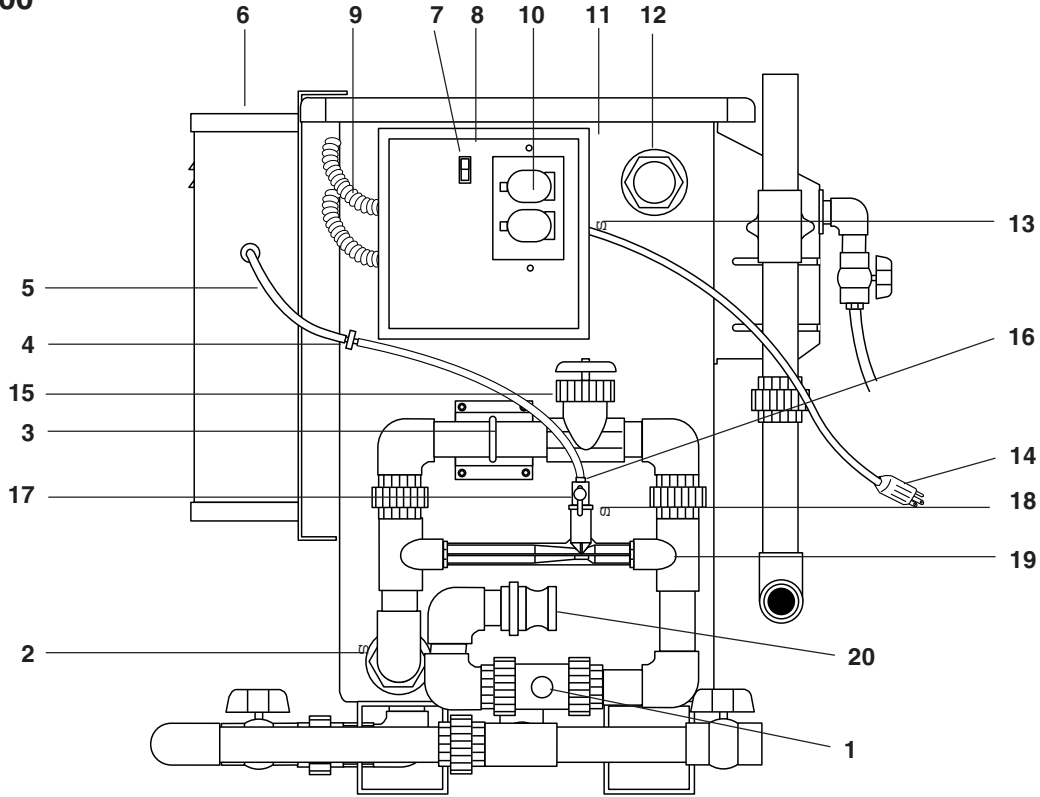

ITEM	PART NO.	DESCRIPTION	QTY
1	2-301	Valve, 1" PVC Ball Check	1
2	2-010052	Bulkhead, Cycl. 1-1/2" (3.81 cm) PVC SP 1023	6
2	2-0100155	Bushing, 1-1/2" x 1" (5.08 mm x 3.81 cm) MT x FT, PVC 80	1
3	2-0100192	Hanger, Pipe, 1" (3.81 cm) Clic #32	1
4	2-307	Valve, 3/8" Tubing Check S-46-01-0008	1
5	4-02080002	Tubing, 3/8" x 1/2" Clear Vinyl /ft. (30.48 cm)	3
6	6-0540	Ozone Generator, Series 101 (120V)	1
7	6-020251	Switch, Corvette, 120V & 220V	2
8	6-0374	▲ Relay, Power Omron G4B112T FDCUSR PAC 120	1
	6-03907	Box, Plastic, 8" x 8" x 4" (20.32 cm x 20.32 cm x 10.16 cm), w/Lid	1
	95-07500090	Panel Control, Alpha	1

ITEM	PART NO.	DESCRIPTION	QTY
9	6-05152	Strain Relief	2
10	6-0408	Receptacle, Duplex, 115V	1
	6-0409	Cover, SC, Duplex, 3780SC	1
11	95-075001001	Tank Assy Welded, Alpha 1500 Stainless Steel	1
12	2-010052	Bulkhead, Clyc, 1-1/2" (3.81 cm) SP1023	1
13	6-05180	Connector, Strain Relief, TB2522	1
14	6-04011	Plug Male, 115V, 15 amp Heavy Duty	1
15	2-3034	Valve Gate, PVC 1" (2.54 cm), FIPT x FIPT	1
16	2-01117	Connector, Male (Poly) 3/8" x 1/4" (9.53 mm x 6.35 mm)	1
17	2-30157	Valve, Ozone Metering, Plastic	1
18	2-01118	Nipple, Hex Red, 1/2" x 1/4" (12.7 mm x 6.35 mm) (Poly)	1
19	3-1403	Injector, Ozone	1
20	2-2020	Camlock, 1-1/2" (3.81 cm) Male x MPT	1

▲ Not Shown

INLET SIDE (FRONT) ALPHA-3100

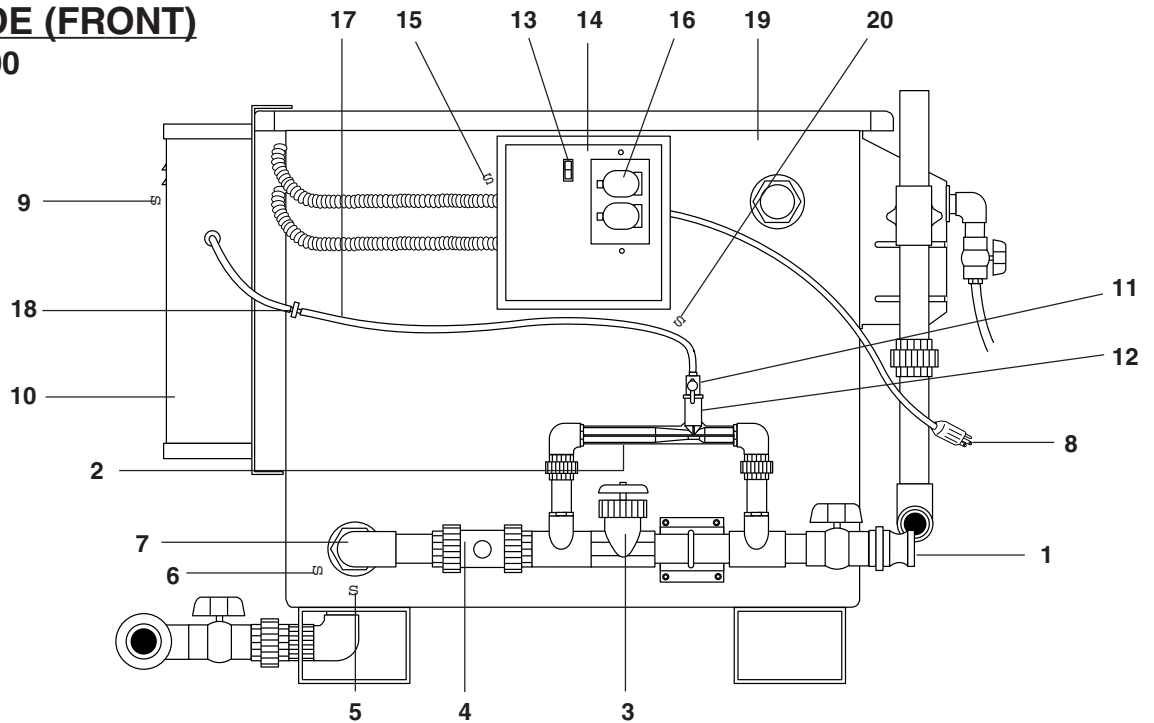

ITEM	PART NO.	DESCRIPTION	QTY
	91-WMA150	Alpha Inlet Manifold Assy, 1-1/2" (3.81 cm)	1
1	2-2020	Camlock 1-1/2" (3.81 cm) Male x MPT	1
2	3-1403	Injector, Ozone	1
3	2-3035	Valve, Gate, PVC, 1-1/2" (3.81 cm) Slip x Slip	1
4	2-30095	Valve, 1-1/2" (3.81 cm) PVC, Ball Check	1
5	2-01002	Nipple, PVC Close, 1-1/2" (3.81 cm)	1
6	2-010052	Bulkhead, Clyc. 1-1/2" (3.81 cm) PVC SP1023	1
7	2-0100132	Elbow, PVC 80, 1-1/2" (3.81 cm) Slip x FIPT	1
8	6-04011	Plug, Male 115V, 15 amp Heavy Duty	1
9	6-02053	Light, Indicator, Red, 125V	1
10	6-0540	Ozone Generator, Series 101 (120V)	1
	6-0534	▲ Lamp, S-1200 Ozone Replacement	1
	6-05233	▲ Connector, 4 Pin Plug	1
10	6-05231	▲ Ballast, 120V, Ozone Generator	1

ITEM	PART NO.	DESCRIPTION	QTY
11	2-30157	Valve, Ozone Metering, Plastic	1
12	2-01118	Nipple, Hex Red, 1/2" x 1/4" (12.7 mm x 6.25 mm) Poly	1
13	6-020251	Switch, Curvette, 120V & 220V	2
14	6-03907	Box, Plastic, 8" x 8" x 4" (20.32 cm x 20.32 cm x 10.16 cm) , w/Lid	1
	95-07500090	Panel Control, Alpha	1
	10-4010	Label, Alpha Control Panel	1
	6-05180	Connector, Strain Relief, TB2522	1
	6-0374	▲ Relay, Power Omron	1
15	6-05152	Strain Relief	2
16	6-0408	Receptacle, Duplex, 115V	1
	6-0409	Cover, SC, Duplex, 3780-SC	1
17	4-02080002	Tubing, 3/8" x 1-1/2" (9.53 mm x 3.81 cm) Black Vinyl /ft. (30.48 cm)	3
18	2-307	Valve 3/8" (9.53 mm) Tubing Check	1
19	95-07121020	Tank Only, Alpha-3100, Stainless Steel	1
20	2-01117	Connector, Male (Poly) 3/8" x 1/4" (9.53 mm x 6.25 mm)	1

▲ Not Shown

RIGHT SIDE VIEW
ALPHA 1500

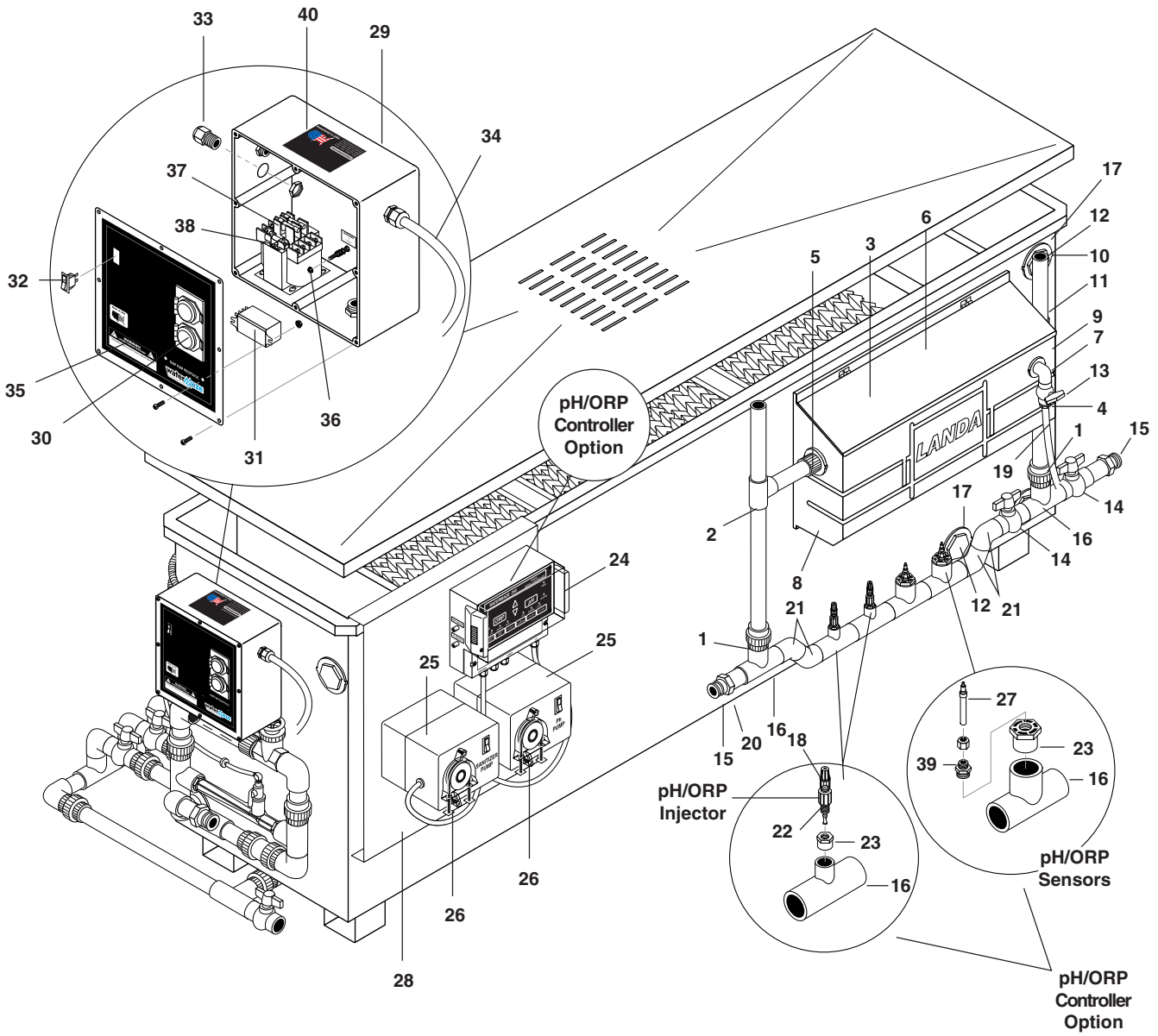

RIGHT SIDE VIEW ALPHA 1500 PARTS LIST

ITEM	PART NO.	DESCRIPTION	QTY	ITEM	PART NO.	DESCRIPTION	QTY
1	2-0100430	Union, 1-1/2" (3.81 cm) S x S	2	20	2-0100312	Adapter, 1-1/2" FT x 1-1/2" Slip (3.81 cm x 3.81 cm)	2
2	2-01002032	Tee, 1-1/2" (3.81 cm) S x S x T	2	21	2-0100133	Elbow, 1-1/2" Slip x Slip x Slip, PVC 80, 45°	4
3	2-0100132	▲ Elbow, 1-1/2" (3.81 cm) SLIP x FIPT, PVC 80, 90°	1	22	2-0100159	Bushing, 1/2" x 1/4" MT x FT	2
4	2-11081	Push-On Barb 3/4" x 3/4" (19.05 mm x 19.05 mm) MPT	1	23	2-0100158	Bushing, 1-1/2" x 1/2" SPG x FT4	
5	2-01002	Nipple, PVC 80 1-1/2" (3.81 cm)	1	24	66-CH250-24	Controller Only, CH250 ORP/pH, Digital	1
6	95-075001053	▲ Slide, Stainless	1	25	5-2359	Pump, Metering, 24V	2
	95-075001050	▲ Trough Assembly	1	26	66-800431	Tubing, 15' Roll	2
7	2-01001326	Elbow, 90° 3/4" (19.05 mm) FIPT x FIPT	1		4-02080007	▲ Tube	2 ft.
8	2-01164	Float Tank	1	27	66-122	Sensor, pH	1
9	2-010058	Bulkhead, 3/4" (19.05 mm) Plastic	1		66-123	▲ Sensor, ORP	1
10	2-010049	▲ Bulkhead, 1/2" (12.7 mm) Plastic	2	28	95-02500019	Bracket, pH/ORP Controller	1
	2-01001391	▲ Plug, 1/2" MIPT, PVC 80	1	29	6-03907	Box, Plastic, 8 x 8 x 4	1
11	2-010052	Bulkhead, Cyc. 1-1/2" (3.81 cm) SP1023	4	30	6-0408	Receptacle, Duplex, 115V	1
	2-01006	▲ Nipple, PVC 80, 1-1/2" x 2-1/2" (3.81 cm x 6.35 cm)	1	31	6-0374	Relay, Power Omron	1
12	2-0100146	Plug, 1-1/2" (3.81 cm), PVC 80	3	32	6-020251	Switch, Corvette	1
13	2-3092	Ball Valve, 3/4" (19.05 mm) PVC	1	33	6-05153	Strain Relief	2
14	2-3093	Valve, 1-1/2" S x S	2	34	6-01041	Cord, Electric, 12/3	15ft
15	2-2020	Adapter, 1-1/2" Male x 1-1/2" Male Thrd Camlock (3.81 cm x 3.81 cm)	1	35	10-4010	Label, Control Panel	1
16	2-0100201	Tee, 1-1/2" S x S x S	2	36	6-60121	Transformer, Micron, 120/240V-24V, .050 KVA	1
17	2-010052	Bulkhead, Cyc, 1-1/2" (3.81 cm) SP 1023	6	37	6-02299	Fuse, KTK-R2, 600V	2
18	66-8800712	Injector	2	38	6-02320	Fuse, 2-1/2 Amp, 250V	1
19	4-02120000	Hose, Push-On, 3/4" (19.05 mm) (30.48 cm)	1.5 ft.	39	66-524	Compression Fitting	2
				40	10-08023	Label, Assembled In USA	1
						▲ Not Shown	

RIGHT SIDE VIEW
ALPHA-3100

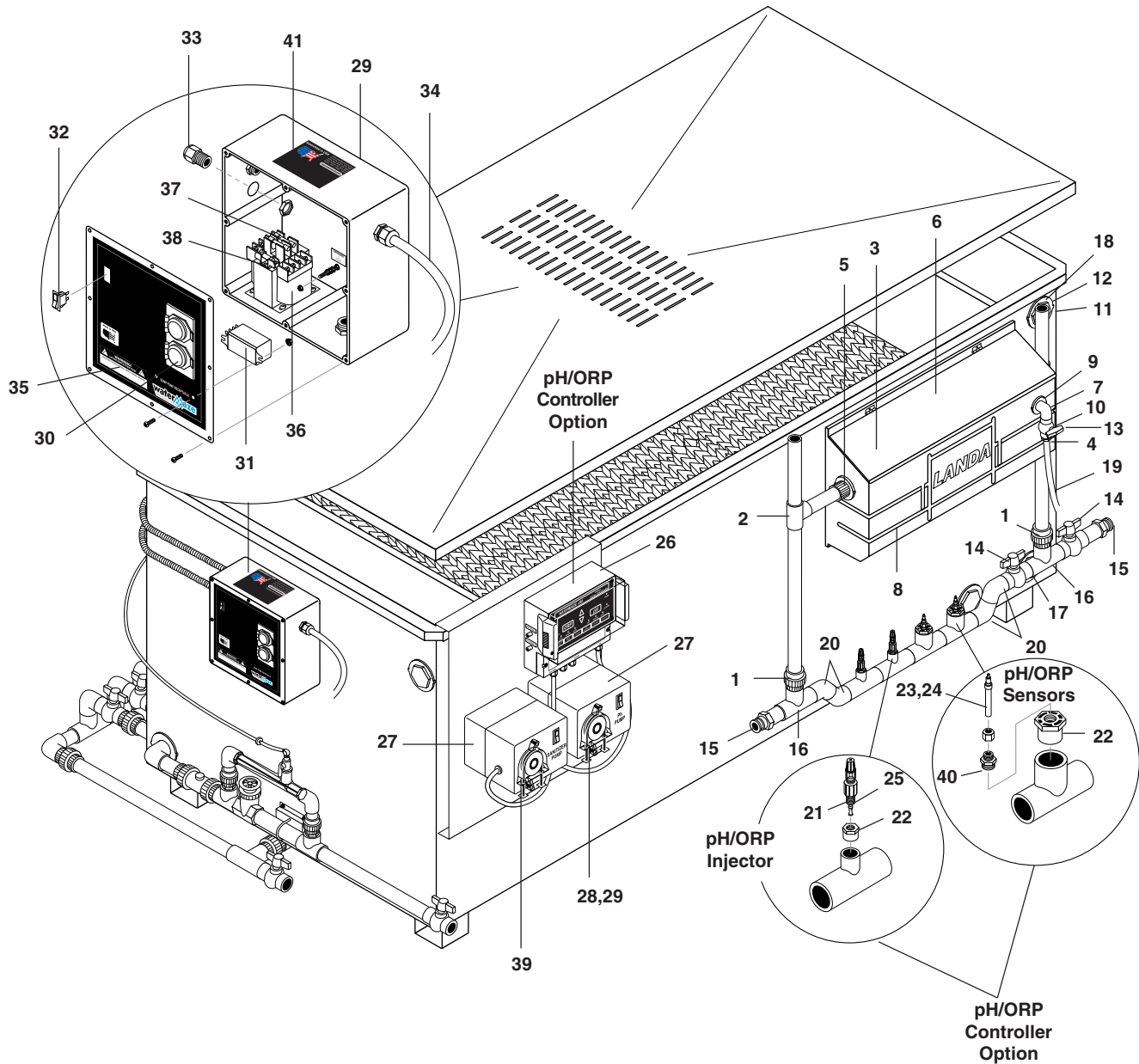

**RIGHT SIDE VIEW
ALPHA-3100 EXPLODED VIEW**

ITEM	PART NO.	DESCRIPTION	QTY	ITEM	PART NO.	DESCRIPTION	QTY
1	2-0100430	Union, 1-1/2" (3.81 cm) S x S	2	20	2-0100133	Elbow, 1-1/2" Slip x Slip, PVC 80, 45°	4
2	2-01002032	Tee 1-1/2" (3.81 cm) S x S x T	2	21	2-0100159	Bushing, 1/2" x 1/4" MT x FT	2
3	2-0100132	▲ Elbow, 1-1/2" (3.81 cm) S x FIPT	1	22	2-0100158	Bushing, 1-1/2" x 1/2" SPG x FT4	
4	2-11081	Push-On Barb, 3/4" x 3/4" (19.05 mm x 19.05 mm) MPT	1	23	66-122	Sensor, pH	1
5	2-01002	Nipple, PVC 80 1-1/2" (3.81 cm)	1	24	66-123	Sensor ORP	1
6	95-075001053	▲ Slide, Stainless	1	25	66-8800172	Injector, IPF	2
	95-075001050	▲ Through Assembly	1	26	66-CH250-24	Controller Only, CH250 ORP/pH Digital	1
	2-01251	▲ Gasket, Oil Skimmer	1	27	5-2359	Pump, Metering, 24V	2
7	2-01001326	Elbow, 90° 3/4" (19.05 mm) FIPT x FIPT	1	28	66-8800431	Tubing, 15' Roll	2
8	2-01164	Float Tank	1	29	6-03907	Box, Plastic, 8" x 8" x 4"	1
9	2-010058	Bulkhead, 3/4" (19.05 mm) Plastic	1	30	6-0408	Receptacle, Duplex, 115V	1
10	2-01001	Nipple, Close 3/4" (19.05 mm)	1	31	6-0374	Relay, Power Omron	1
11	2-01002	Nipple, PVC 80, 1-1/2" Close (3.81 cm)	1	32	6-020251	Switch, Curvette	1
12	2-010049	▲ Bulkhead Fitting, 1/2" (12.7 mm) PVC	1	33	6-05153	Strain Relief	2
13	2-3021	Valve, 3/4" (19.05 mm) PVC Ball	1	34	6-01041	Cord, Electric, 12/3	15 ft.
14	2-3093	Valve, 1-1/2" (3.81 cm) S x S	2	35	10-4010	Label, Control Panel	1
15	2-2020	Adapter, 1-1/2" Male x 1-1/2" Male Thrd Camlock (3.81 cm x 3.81 cm)	2	36	6-60121	Transformer, Micron, 120/240V-24V, .050 KVA	1
16	2-0100201	Tee, 1-1/2" (3.81 cm) S x S x S	2	37	6-02299	Fuse, KTK-R2, 600V	2
17	2-010052	Bulkhead, Cyc, 1-1/2" (3.81 cm) SP 1026	6	38	6-02320	Fuse, 2-1/2 Amp, 250V	1
18	2-0100146	Plug, 1-1/2" (3.81 cm) PVC 80	4	39	4-02080007	Tube	2 ft.
19	4-02120000	Hose, Push-On, 3/4" (19.05 mm) (30.48 cm)	1.5 ft.	40	66-524	Compression Fitting	2
				41	10-08023	Label, Assembled In USA	1

▲ Not Shown

DISCHARGE SIDE
ALL MODELS

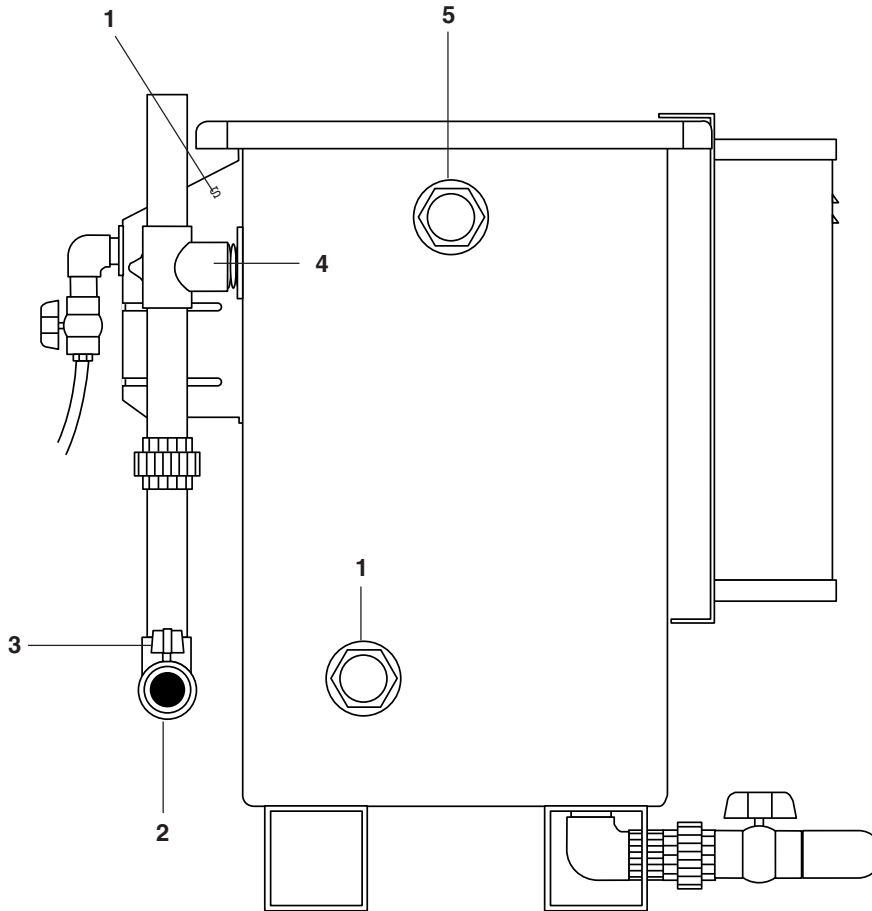

ITEM	PART NO.	DESCRIPTION	QTY
1	2-01001391	Plug, 1/2" (12.7 mm) MIPT PVC 80	2
	2-010049	Bulkhead, 1/2" (12.7 mm) PVC	2
2	2-2020	Camlock, 1-1/2" (3.81 cm) Male x MPT	2
3	2-3093	Valve Ball, PVC 1-1/2" (3.81 cm) S x S	2
4	2-01002	Nipple, PVC 80, 1-1/2" (3.81 cm) Close	1
5	2-0100146	Plug, 1-1/2" (3.81 cm) PVC 80	4
	2-010052	Bulkhead, Cyc. 1-1/2" (3.81 cm) SP 1023	6

TOP VIEW ALPHA-1500

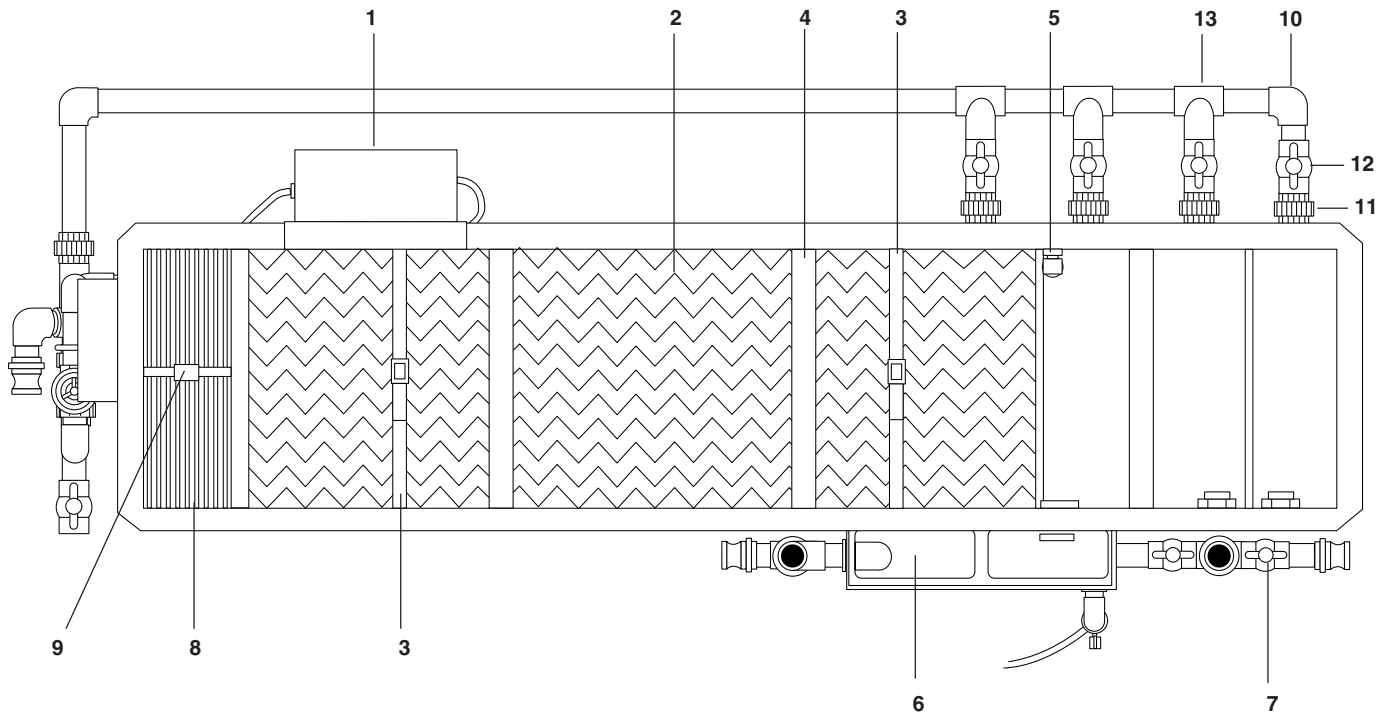

ITEM	PART NO.	DESCRIPTION	QTY
1	6-0540	Ozone Generator Series 101 (120v)	1
	6-0534	▲ Lamp, S-1200 Ozone Replacement	1
	6-05233	▲ Connector, 4 Pin Plug	1
	6-05231	▲ Ballast, 120v, Ozone Generator	1
2	2-01174	Grid, Horizontal Coalescing Alpha-1500	16
	2-01180	Grid, Horizontal Coalescing Alpha-500	16
3	30-737	Strap, Coalescing Grid, 112" (284.48 cm) Alpha-500 Alpha-1500	1 2
4	95-07500013	Retainer, Coalescing Pack, SS Alpha	1
5	6-0933	Switch, Liquid Level	1

ITEM	PART NO.	DESCRIPTION	QTY
6	30-534	Oil Skimmer Assembly	1
7	2-3093	Valve, Ball, 1-1/2" (3.81 cm) S x S	2
8	2-011731	Grid, Vertical Coalescing Alpha 4	4
9	30-727	Strap Coalescing Grid, 60" (152.4 cm)	1
	95-07500093	▲ Cover, Lid Alpha-1500, Aluminum	1
	95-07500094	▲ Cover, Lid Alpha-500, Aluminum	1
10	2-01001322	Elbow, 1.5" SxS PVC 80 90°	2
11	2-0100430	Union, 1.5" SxS, PVC 80	5
	2-0100302	▲ Adaptor, 1.5" SxMT	5
12	2-3093	Valve 1.5" S80 PVC SxS	5
13	2-0100201	Tee, 1.5" SxSxS, PVC 80	4
		▲ Not Shown	

TOP VIEW
ALPHA-3100

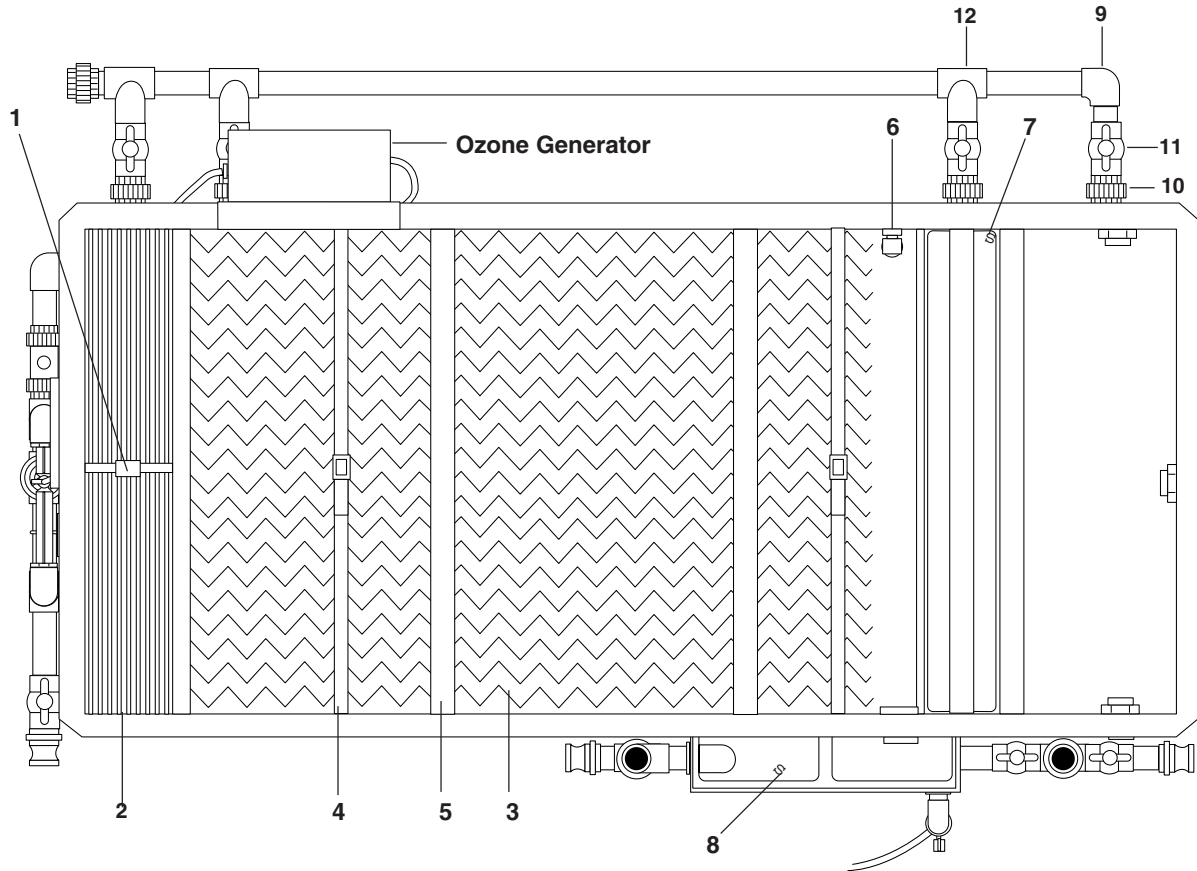

ITEM	PART NO.	DESCRIPTION	QTY
1	30-727	Strap, Coalescing Grid, 60"	1
2	2-01173	Grid Vertical Coalescing	9
3	2-01174	Grid Horizontal Coalescing	36
4	30-737	▲ Strap, Coalescing Grid 112" (284.48 cm)	2
5	95-07500003	Retainer, Coalescing Pack, SS	3
6	6-0933	Switch, Liquid Level	1
7	2-01175	Suitcase, Pom Pom Filters	1
	2-01176	▲ Pom Pom, Sorbaid	2
8	30-534	Oil Skimmer Assembly	1

ITEM	PART NO.	DESCRIPTION	QTY
8	95-075001050	Skimmer Trough	1
	2-01251	Gasket, Oil Wheel	1
	95-045001051	Face Plate Assembly	1
	95-07500092	▲ Cover, Lid Alpha-3100, Aluminum	1
9	2-01001322	Elbow, 1.5" SxS, PVC 80	1
10	2-0100430	Union, 1.5" SxS, PVC 80	4
	2-0100302	▲ Adaptor, 1.5" SxMT	4
11	2-3093	Valve 1.5" S 80 SxS	4
12	2-0100201	Tee, 1.5" SxSxS, PVC 80	3

▲ Not Shown

TROUBLESHOOTING

PROBLEM	POSSIBLE CAUSE	SOLUTION
NO FLOW OF WATER INTO ALPHA	Control switch not in "ON" position	Turn switch to "ON" position.
	Water in sump not high enough to activate level switch	Lift float level switch and see if pump turns on.
	Alpha not plugged in	Plug in Alpha.
	High level limit switch shut off	Check on/off functioning. Adjust, repair or replace.
	Debris in pump impeller	Unplug pump and remove from container. Check impeller. Clean/repair.
	Flow control valve in "OFF" position	Open valve.
	Dirt collection chamber full	Drain and clean.
	Dirt lodged in control valve or check valve	Clean as needed.
	Frozen water in lines or valves	Thaw out with warm water.
EXCESSIVE WATER FLOWING INTO OIL SKIMMER	Tank not level end to end or side to side	Level tank.
	High level limit switch not functioning	Check ON/OFF functioning. Adjust, repair or replace.
	Water coming into Alpha faster than machine is rated for	Adjust flow control valve.
	Oil sheen filter pack plugged (Alpha 3100)	Remove and clean.
	Discharge line plugged or valve closed	Remove obstruction or open valve.
OIL ON TOP OF WATER IN EXIT CHAMBER	Oil sheen filter pack not firmly in place (Alpha 3100)	Push down on filter firmly to lock in place.
	Oil sheen filter pack dirty (Alpha 3100)	Remove and replace/clean media.

TROUBLESHOOTING

PROBLEM	POSSIBLE CAUSE	SOLUTION
PUMP WON'T START	Tripped breaker	Reset breaker.
	Low line voltage	If voltage under recommended minimum, check size of wiring from main switch on property. If OK, contact power company.
	Defective motor	Replace motor.
	Pump filled with mud or debris	Remove pump base and clean out mud or debris.
PUMP STARTS AND STOPS TOO OFTEN	Low line voltage	If voltage under recommended minimum, check size of wiring from main switch on property. If OK, contact power company.
	Long extension cords	Shorten extension cord.
	Clogged impeller	Remove housing, unclog.
	Faulty motor protector	Replace pump.
	Very low head or lift	Increase head or lift.
	Back flow of water from long discharge line	Add check valve as close as possible to pump (see installation).
	Sump pit too small	Increase size of pit.
PUMP WON'T SHUT	Defective float switch	Replace.
OFF PUMP OPERATED BUT DELIVERS LITTLE OR NO WATER	Low line voltage	If voltage under recommended minimum, check size of wiring from main switch on property. If OK, contact power company.
	Fouled sediment screen	Clean, repair or replace as needed.
	Worn or defective pump parts or plugged impeller	Replace worn parts or entire pump. Clean parts if required.
	Pump air locked	Turn pump "On-Off" several times. Fill hose manually with water.
	Wear plate and impeller worn	Check and replace if needed.

PREVENTATIVE MAINTENANCE

This Alpha machine was produced with the best available materials and quality craftsmanship. However, you as the owner have certain responsibilities for the correct care of the equipment. Attention to regular preventative maintenance procedures will assist in preserving the performance of your equipment. Contact your WATER MAZE, Inc. dealer for maintenance. Regular preventative maintenance will add many hours to the life of your pressure washer. Perform maintenance more often under severe conditions.

MAINTENANCE SCHEDULE	
System Flow Rate - Check visually Alpha 3100 - Completely covering exit pipe All Units: Make sure the overflow switch in the coalescing chamber is not "cycling"	Daily
Exit Pipe - Check for obstructions	Daily
Ozone Generator - Check indicator light. (light "on" indicates malfunction)	Daily
Check control panel to make sure switches are on and voltage is connected to unit	Daily
Check all plumbing for leaks	Daily
Check water chemistry and make needed adjustments	Daily
Coalescing Chamber - Check for solids accumulation. Clean out if over 4" of solids	Weekly
Ozone Generator - Check air flow. Set to 10 SCFM	Monthly
Inlet (first) Chamber - Check for solids accumulation. Clean as required	Monthly
Suck sludge and debris from pits	Monthly
Check sump pump and if necessary clean out dirt and debris	Monthly
Clean dirt or grease from float	Monthly
Check float wires for cuts or frays	Monthly
Coalescing Plates - Remove and inspect. Clean with warm water - no detergents. When reinstalling make sure pack fits snug to bottom	Monthly
Oil Skimmer - Drain off oil layer if over 1/2" (12.7 mm) thick. Close drain when done. Check input flow to skimmer. Adjust "slot" height for flow rate of "just a trickle"	Monthly or as needed
Alpha 3100 Only Remove "suitcase filter". Open, remove and rinse "pom pom filters." Use warm water - no detergents. Reassemble and install	Quarterly or as needed
Ozone Generator Bulb - Replace	As needed

SPECIFICATIONS

MODEL		ALPHA 1500	ALPHA 3100
FLOW RANGE	GPM (LPM)	0-15 (56.78)	0-30 (113.55)
HOLDING CAPACITY	GAL (LTR)	125 (473.13)	250 (946.25)
ELECTRICAL	V/AMP	120/12	120/12
COALESCING PACK		500 sq. ft. (152.35)	1000 sq. ft. (304.79)
OZONATOR		Series 101	Series 101
SUMP PUMP		1/2 HP, 120V (.37 kw)	1/2 HP, 120V (.37 kw)
OIL SKIMMER		Manual	Manual
TANK MATERIAL		Stainless Steel	Stainless Steel
DIMENSIONS	L/W/H IN (CM)	80/36/31" (203.2/91.44/78.74)	83/48/32" (210.82/121.92/81.28)
MACHINE ONLY WEIGHT	LBS (KG)	325 (147.73)	490 (222.73)
SHIPPING WEIGHT	LBS (KG)	545 (247.73)	760 (345.45)



LIMITED NEW PRODUCT WARRANTY WASH WATER / WATER TREATMENT SYSTEMS

WHAT THIS WARRANTY COVERS

All *WATER MAZE* water treatment systems are warranted by to the original purchaser to be free from defects in materials and workmanship under normal use, for the periods specified below. This Limited Warranty, subject to the exclusions shown below, is calculated from the date of the original purchase, and applies to the original components only. Any parts replaced under this warranty will assume the remainder of the part's warranty period. A 60 day grace period will be given for installation.

ONE YEAR PARTS AND 30 DAY LABOR WARRANTY:

All components excluding normal wear items as described below.

WARRANTY PROVIDED BY OTHER MANUFACTURERS:

Motors, which are warranted by their respective manufacturers, are serviced through these manufacturers' local authorized service centers. *WATER MAZE* cannot provide warranty on these items.

WHAT THIS WARRANTY DOES NOT COVER

This warranty does not cover the following items:

1. Normal wear items, such as seals, filters, gaskets, O-rings, packings, pistons, brushes, filtering media, ozone bulbs, sensors, UV scanners, oil-skimmer belt, impedance sensor. O-rings and minor leaks covered first time on original start-up only.
2. Damage or malfunctions resulting from accidents, abuse, modifications, alterations, incorrect installation, improper servicing, failure to follow manufacturer's maintenance instructions, or use of the equipment beyond its stated usage specifications as contained in the operator's manual.
3. Damage due to freezing, sludge build-up, chemical deterioration (oxidation, chloride or fluoride corrosion), and rust.
4. Damage to components from fluctuations in electrical or water supply.
5. Normal maintenance service, including adjustments.
6. Transportation to service center, field labor charges, or freight damage.
7. Death of microbes (Biostax 900 and 100)

WHAT YOU MUST DO TO OBTAIN WARRANTY SERVICE

While not required for warranty service, we request that you register your *WATER MAZE* Product by returning the completed registration card. In order to obtain warranty service on items warranted by *WATER MAZE*, you must return the product to your Authorized *WATER MAZE* Dealer, freight prepaid, with proof of purchase, within the applicable warranty period. If the product is permanently installed, you must notify your Authorized *WATER MAZE* Dealer of the defect. Your Authorized *WATER MAZE* Dealer will file a claim with *WATER MAZE*, who must subsequently verify the defect. In most cases, the part must be returned to *WATER MAZE* freight prepaid with the claim. For warranty service on components warranted by other manufacturer's, your Authorized *WATER MAZE* Dealer can help you obtain warranty service through these manufacturers' local authorized service centers.

LIMITATION OF LIABILITY

WATER MAZE'S liability for special, incidental, or consequential damages is expressly disclaimed. In no event shall *WATER MAZE'S* liability exceed the purchase price of the product in question. *WATER MAZE* makes every effort to ensure that all illustrations and specifications are correct, however, these do not imply a warranty that the product is merchantable or fit for a particular purpose, or that the product will actually conform to the illustrations and specifications. **THE WARRANTY CONTAINED HEREIN IS IN LIEU OF ALL OTHER WARRANTIES, EXPRESS OR IMPLIED, INCLUDING ANY IMPLIED WARRANTY OF FITNESS FOR THE PARTICULAR PURPOSE, INCLUDING QUALITY OF WATER TREATMENT.** *WATER MAZE* does not authorize any other party, including authorized *WATER MAZE* Dealers, to make any representation or promise on behalf of *WATER MAZE*, or to modify the terms, conditions, or limitations in any way. It is the buyer's responsibility to ensure that the installation and use of *WATER MAZE* products conforms to local codes. While *WATER MAZE* attempts to assure that its products meet national codes, it cannot be responsible for how the customer chooses to use or install the product.



Form #8.913-964.0 • 96-629 • Revised 8/08 • Printed in U.S.A.