



# HBG

## OPERATOR'S MANUAL

---

■ HBG-15

■ HBG-30

---

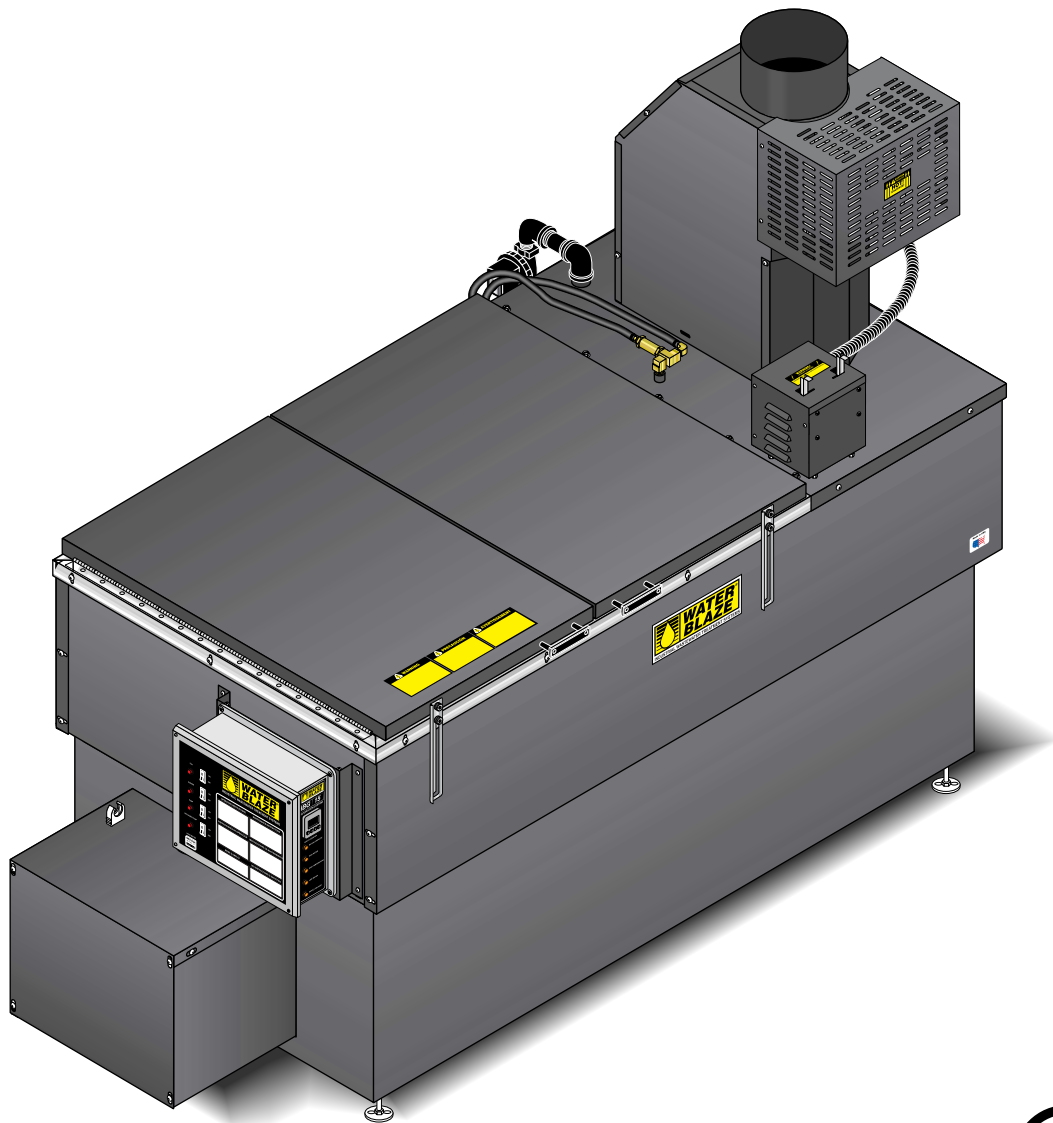

---

For technical assistance or the dealer nearest you consult our web page at [www.waterblaze.com](http://www.waterblaze.com) or call (800-562-4993) or (360) 833-2874



## CONTENTS

Introduction .....	5
General Safety Information .....	5-6
Electrical Safety Information .....	6
Standard Safety Features .....	6-7
Installation .....	7-9
HBG-15, HBG-30 Component Identification .....	8
Gas Pressure Test .....	9-10
Pre Start Checklist .....	10
Operating Instructions .....	11
Maintenance .....	12
HBG Fuel and Air Settings .....	12
Auto Fill Operating Characteristics .....	13
Air Assisted Defoamer Operating Characteristics .....	13
Batch Cycle Counter .....	14-16
Installation Dimensions .....	17
Exploded View HBG-15 .....	18-19
Exploded View Parts List HBG-15 .....	20-21
Exploded View HBG-30 .....	22-23
Exploded View Parts List HBG-30 .....	24
Control Panel Exploded View & Parts List .....	25
HBG-15 Float Assembly Exploded View .....	26
HBG-15 Float Assembly Parts List .....	27
HBG-30 Float Assembly Exploded View .....	28
HBG-30 Float Assembly Parts List .....	29
HBG Auto Fill Option Exploded View .....	30
HBG Auto Fill Option Parts List .....	31
HBG Defoamer Option Exploded View .....	32
HBG Defoamer Option Parts List .....	33
HBG Oil Skimmer Option Exploded View .....	34
HBG Oil Skimmer Option Parts List .....	35
Replacing Pump Head Tubing .....	36
VSP20 Metering Anti-Foam Pump .....	37
Burner Assembly HBG-30 #HSG400 & Parts List .....	38-39
Gas Train Assembly and Parts List .....	39

# CONTENTS

Troubleshooting ..... 40-41  
HBG Cost Formulas ..... 42  
Specifications ..... 42  
Preventative Maintenance ..... 43  
Warranty ..... 44

Model Number _____
Serial Number _____
Date of Purchase _____
The model and serial numbers will be found on a decal attached to the evaporator. You should record both serial number and date of purchase and keep in a safe place for future reference.

## INTRODUCTION

Thank you for purchasing a *WATER BLAZE* HBG.

This manual covers the operation and maintenance of HBG evaporators. All information in this manual is based on the latest product information available at time of printing.

*WATER BLAZE* reserves the right to make changes at any time without incurring any obligation.

### Owner/User Responsibility:

The owner and/or user must have an understanding of the manufacturer's operating instructions and warnings before using this *WATER BLAZE* machine. Warning information should be emphasized and understood. If the operator is not fluent in English, the manufacturer's instructions and warnings shall be read to and discussed with the operator in the operator's native language by the purchaser/owner, making sure that the operator comprehends its contents.

Owner and/or user must study and maintain for future reference the manufacturers' instructions.

**This manual should be considered a permanent part of the machine and should remain with it if machine is resold.**

**When ordering parts, please specify model and serial number.**

**Please Note:** *WATER BLAZE* is not responsible for procurement of regulatory and/or operating permits that may be required by city, county, state or federal agencies. It is the customer who is responsible for procurement of any hazardous or non-hazardous regulatory and/or operating permits, compliance with codes or other governmental requirements associated with the installation, use, or disposal of waste associated with this equipment. Submerged combustion can be classified as incineration in specific jurisdictions. It is the customer's responsibility for procurement of appropriate local and state permits as needed.

The guidelines listed in the evaporator feasibility report are specific only to the waste stream submitted for the evaluation and estimated emissions. Moreover, *WATER BLAZE* is not responsible for the operation or maintenance of the evaporator unit. If the unit is subjected to any waste stream other than that which has been tested by the named laboratory, operation may cause adverse effects on the equipment and will negate any warranty of parts or equipment.

## IMPORTANT SAFETY INFORMATION

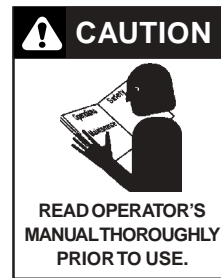

**CAUTION:** To reduce the risk of injury, read operating instructions carefully before using.

1. Read the owner's manual thoroughly. Failure to follow instructions could cause a malfunction of the evaporator and result in death, serious bodily injury and/or property damage.

**CAUTION:** Read the information on the serial plate and burner labels to verify proper fuel connection.

2. All installations must comply with local codes. Contact your electrician, plumber, utility company or the selling distributor for specific details.



3. To protect the operator from electrical shock, the machine must be electrically grounded. It is the responsibility of the owner to connect this machine to a UL grounded receptacle of proper voltage and amperage ratings. Do not touch machine with wet hands or while standing in water. Always disconnect power before servicing.

4. Never make adjustments on the machine while it is in operation except those prescribed in this manual.

**CAUTION:** Use extreme caution when opening the lid of the evaporator. Hot and possibly corrosive steam will be emitted.

5. DO NOT use concentrated flammable liquids that could pose an explosion hazard.



**WARNING:** Flammable liquids can create fumes which can ignite causing property damage or severe injury.

6. **WARNING:** DO NOT attempt to evaporate flammable wastes of any kind, i.e., DO NOT process solvents, pure oils, etc.
7. DO NOT locate machine in the vicinity of any flammable vapors, liquids or solids.
8. Before servicing the machine, refer to all MSDS's on the material identified in the waste stream. You must comply with all warnings and wear all protective clothing stated on the MSDS.
9. When the machine is working, do not cover or place in a closed space where ventilation is insufficient. Avoid installing machines in small confined areas. Adequate oxygen is needed for the evaporation process.

10. The HBG and components will freeze if not in operation. In cold climates locate HBG in heated enclosure.
11. Running the system without water damages the tank floor and voids the warranty.  
**NOTE:** Allow tank to cool before adding wastewater or damage will occur to tank floor due to thermal shock.
12. The HBG must be installed and training provided by an authorized dealer.
13. Do not operate the equipment in an unvented, enclosed area. Carbon monoxide may accumulate.



14. If you smell gas, shut off the gas supply valve, extinguish any open flame and test all joints with a soap solution. If the odor persists, call your gas supplier immediately.
15. Only those liquid wastes that have been approved by *WATER BLAZE*, and the proper regulatory agencies, should be placed

in the HBG machine. Test methods as outlined in *WATER BLAZE* Profile 3518 must be obtained. **NOTE:** *WATER BLAZE* is not liable for the performance and the warranty will be void when waste liquids that are not tested and approved are introduced into the HBG.

<b>FOR YOUR SAFETY READ BEFORE LIGHTING</b>
<b>WARNING</b>
If you do not follow these instructions exactly, a fire or explosion may result, causing property damage, personal injury or loss of life.
A. This appliance has a pilot which must be electrically ignited. <i>When lighting the pilot, follow these instructions exactly.</i>
B. Before lighting, smell all around the appliance area for gas. Be sure to smell next to the floor because some gas is heavier than air and will settle on the floor.
<b>FOR YOUR SAFETY WHAT TO DO IF YOU SMELL GAS</b>
<ul style="list-style-type: none"> <li>• Do not try to light any appliance.</li> <li>• Do not touch any electrical switch. Do not use any phone in the building.</li> <li>• Immediately call your gas supplier from a neighbor's phone. Follow the gas supplier's instructions.</li> <li>• If you cannot reach your gas supplier, call the fire department.</li> </ul>
C. Use only your hand to push in or turn the gas control knob. Never use tools. If the knob will not push in or turn by hand, don't try to repair it. Call a qualified service technician. Attempted repair or use of force may result in a fire or explosion.
D. Do not use this appliance if any part has been under water. Immediately call a qualified service technician to inspect the appliance and to replace any part of the control system and any gas control which has been under water.

16. Chemistry limitations include:
  - Maximum 1,000 mg/L chlorides for 316L stainless steel.
  - Maximum 20,000 mg/L chlorides for duplex 2205 stainless steel.
  - Maximum 40,000 mg/L chlorides for AL-6XN stainless steel pH between 7.0 and 9.0.
  - Initial oil concentration between 500 and 5,000 mg/L or a corrosion inhibitor for carbon steel.

Deviations from these parameters must be approved by Engineering.

## ELECTRICAL SAFETY



Ground equipment before connecting to the electrical power supply. Failure to ground the equipment can cause a severe or fatal electrical shock hazard. Do not ground to a gas supply line. To avoid dangerous or fatal electrical shock, disconnect the power to the equipment before working on any electrical connection or making any repairs.

Supply voltage must be within  $\pm 10\%$  of the nameplate voltage. Incorrect voltage can cause a fire or seriously damage the equipment and void the warranty. If in doubt, consult a licensed electrician.

Connect the equipment to a dedicated circuit breaker.



**CAUTION:** *This machine is equipped with an electronic ignition system. Lighting of the pilot is accomplished through electronic spark ignition. Do not attempt to light the appliance manually as a burn injury or electrical shock may result.*

## STANDARD SAFETY FEATURES

The HBG uses gas and electricity to operate. This can be a fatal combination if not handled properly. For this reason, the HBG has been designed with safety in mind. You will find these standard safety features on all HBG equipment:

### 1. Batch Cycle Controller

This controller counts how many times the machine has evaporated and refilled. At a predetermined number of batch cycles, the controller will shut down the evaporator. Maintenance must be performed before the batch cycle controller is reset.

## 2. Low Water Float Switch

This float switch insures that there is water covering the floor of the evaporator. When the water level drops to a certain level, the low water float switch turns off the burner.

## 3. High Water Float Switch

This float will turn off the HBG when the water level becomes too high.

## 4. On-Off Switch

The burner on-off switch disconnects power to the burner.

## 5. Manual Reset High Temperature Switch

If the underneath floor temperature below the tank exceeds a maximum temperature HBG-15: mild steel 700°, stainless steel 900°; HBG-30: mild steel 500°, stainless steel 700°, the manual reset temperature switch will trip, turning off the burner. To reset, push black button on side of electrical box.

## INSTALLATION

1. **LOCATION**-Locate the HBG evaporator on a concrete surface and level with leveling feet supplied with the machine.

**NOTE:** Leveling feet must be screwed into the bottom of the flame box when it is removed from pallet. HBG-30's must have fifth leveling foot screwed into the burner support bracket located below the burner. Burner support bracket is to keep the burner level at all times. Protect machine from damaging environments such as wind, rain, sun and freezing temperatures.

**Caution: For natural gas, air ventilation should be located near the ceiling. For liquid propane, air ventilation should be located near the floor. Air ventilation openings and evaporator stack should be located a safe distance from building climate control air intake ducts.**

2. **ELECTRICAL**-The standard HBG requires 120 volts. Refer to the serial plate for proper voltage and amp requirements for your machine. All electrical lines must be tested with a voltage meter for proper voltage before connecting to the HBG.

**CAUTION: All electrical lines must be installed by qualified personnel only. All installations must be electrically grounded and conform to all local and National Electrical codes.**

Use a strain relief at the rear of the control panel for connecting to the main power supply. Electrical conduit must be run all the way to the connection point in accordance with local codes. To connect the power wires inside the electrical box, locate the wiring terminal strip and follow wiring diagram to make sure

black wire is connected to the proper terminal. Connect the white neutral wire to terminal #N. Then connect the ground wire to the grounding stud on the back of the electrical box. Confirm that voltage is going to the correct terminals.

3. **AUTO FILL FLOAT** - Remove float wires from pump switch (black and white wires). With strain relief supplied, attach to wastewater tank near bottom and thread float wires through strain relief and tighten. **Note:** Leave at least a 3 inch tether from the strain relief for float to work correctly. Rewire float wires into pump switch.
4. **GAS PIPING** - All piping must comply with local codes and ordinances or the National Fuel Gas Code ANSI Z223. 1-1984 and NFPA No. 54. A sediment trap or drip leg must be installed in the supply line to the burner.

A union shall be installed in the gas line adjacent to and upstream from the control manifold and downstream from the manual main shut off valve.

A 1/8" N.P.T. plugged tap accessible for test gauge connection shall be installed immediately upstream of the gas supply connection for the purpose of determining the gas supply pressure to the burner.

A manual shut off valve shall be installed in the gas supply line external to the appliance.

The gas line should be a separate supply direct from the meter to the burner. It is recommended that new pipe be used and located so that a minimum amount of work is required in future servicing. Piping should be durable, substantial and gas tight. It should be clear and free from cutting burrs and defects in structure or threading. Cast iron fittings or aluminum tubing should not be used for the main gas supply. Joint compounds (pipe dope) should be used sparingly on male threads only and be approved for all gases.

The building structure should not be weakened by installation of the gas piping. The piping should not be supported by other piping, but should be firmly supported with pipe hooks, straps, bands or hangers. Butt or tap welded pipe should not be bent.

The gas piping should be so installed as to prevent an accumulation of condensation and it must be protected against freezing. A horizontal pipe should be pitched so that it grades toward the meter and is free from sags. The pipe should not be run through or in an air duct or clothes chute.

The HBG and its individual gas valve must be disconnected from the gas supply piping system during any pressure testing of the system at test pressures in excess of 1/2 psig.



**COMPONENT IDENTIFICATION**

**HBG-15 TOP  
HBG-30 BOTTOM**

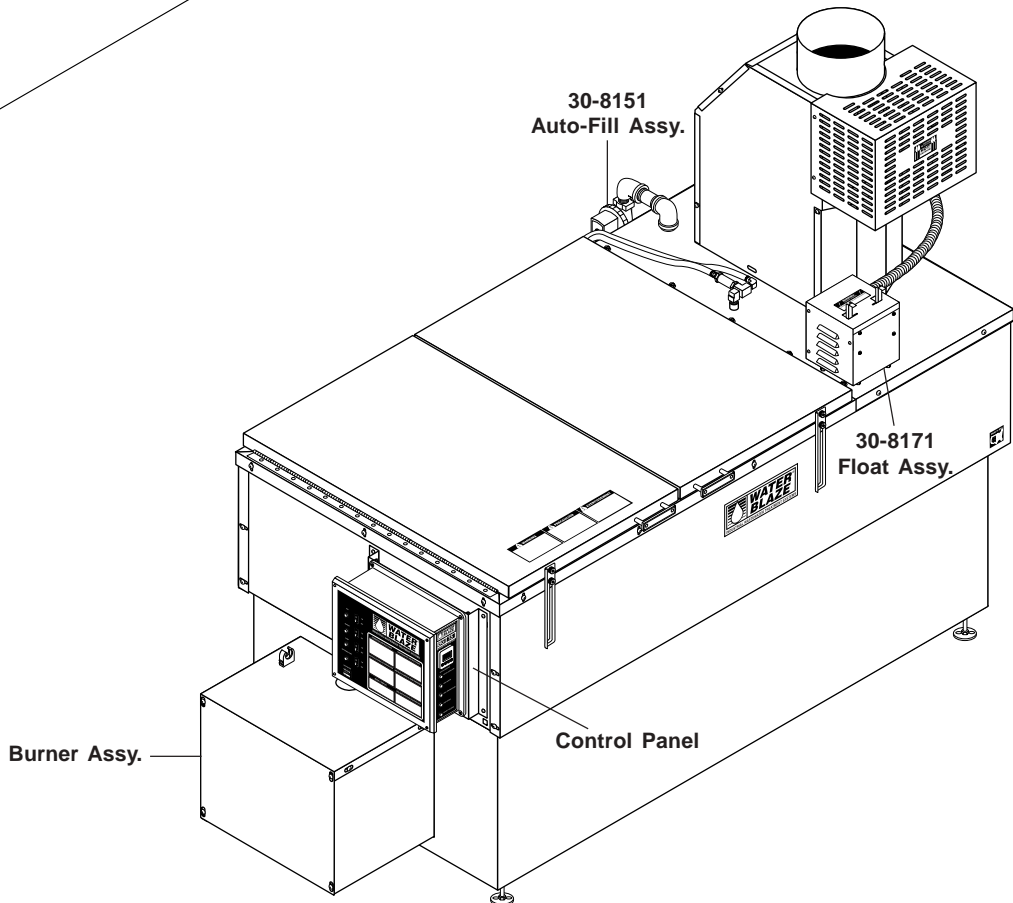
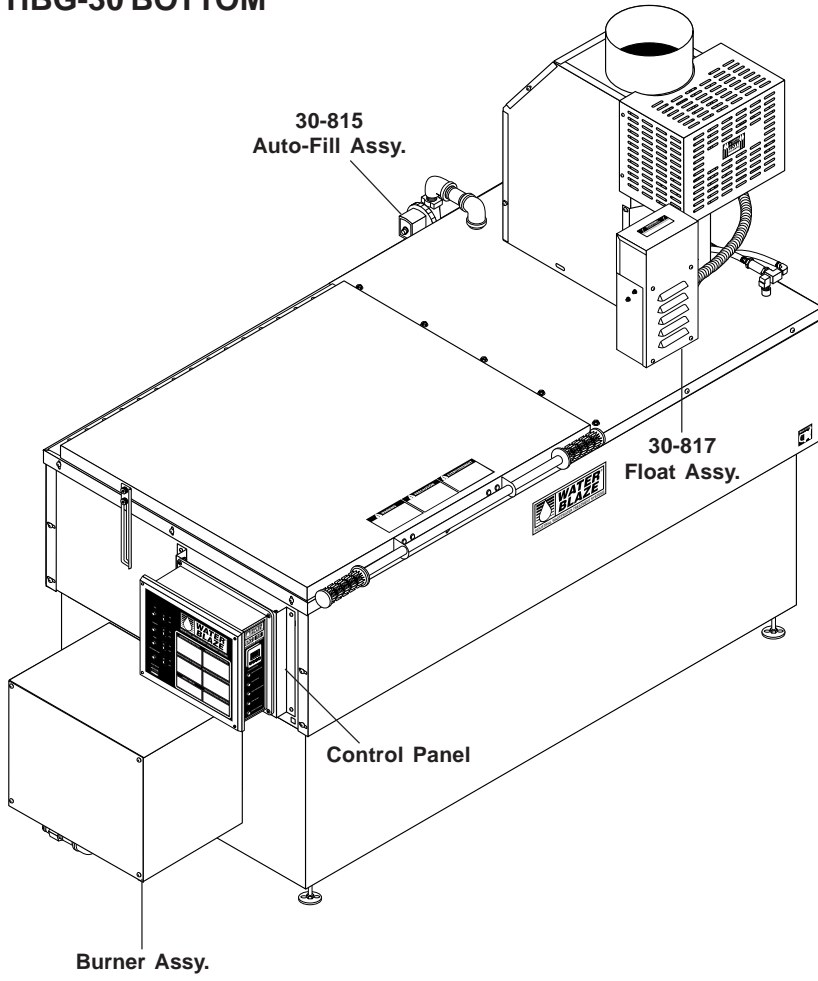



**TESTING PIPING FOR LEAKS** - Before allowing gas under pressure into the piping, all openings from which gas can escape should be closed. Immediately after turning on gas, the system should be checked for leaks. This can be done by watching the 1/2 cubic foot test dial for 5 minutes for any movement, or by soaping each pipe connection and watching for bubbles. If a leak is found, make the necessary repairs and repeat the above test.

Defective pipes or fittings should be replaced and not repaired. Never use a flame or fire in any form to locate gas leaks—use a soap solution.

After the piping and meter have been checked completely, purge the system of air. Be sure to relight all the gas pilots on other appliances.

**PURGING** - After the piping has been checked, all piping and appliances receiving gas through the meter shall be fully purged. A suggested method for purging the gas line to the burner is to disconnect the pilot line at the outlet of the pilot valve. Under no circumstances shall the line be purged into the combustion chamber.

After the gas line to the burner has been fully purged and the pilot line reconnected, the gas supply at other pilot burners, located on other gas appliances which were extinguished as the result of interrupted service, shall be reignited.

**GAS SUPPLY PIPE & PRESSURE** - The burner gas valve will accept a 3/4" (HBG-30) and 1/2" (HBG-15) gas line.

The minimum inlet gas supply pressure is 4.5" W.C. for natural gas and 11.0" W.C. for L.P. gas; the maximum gas supply pressure is 14" W.C. for natural gas

and L.P. gas (vapor). A regulator may be needed to obtain the required pressure. Refer to chart on page 12 for settings.

- WASTEWATER** - Wastewater is introduced into the evaporator using a bucket or the optional autofill pump. A 20 mesh stainless steel strainer protects the pump from debris. The connection between the above ground wastewater tank and the HBG machine is made by using a 3/4" I.D. or larger supply hose with common connectors supplied by the customer. The connection is located on the rear of the machine where the 20 mesh strainer is connected to the pump. *WATER BLAZE* recommends the installation of a ball valve next to the strainer that will allow stoppage of the waste stream during maintenance. A 3" sludge valve (2-30047 brass valve) is recommended (not supplied) to allow easy removal of sludge and concentrated wastewater.

**NOTE:** The HBG optional autofill air diaphragm pump is automatically controlled by floats and will supply wastewater as needed after startup.

**CAUTION: Foaming chemicals will affect the evaporation process in the HBG. An anti-foaming agent may need to be added to counteract the foam.**

An automatic anti-foam dispenser can be used to automatically add anti-foam (#7-8116). Contact your *WATER BLAZE* representative to purchase the defoamer best suited to your application. (Defoamer sold separately.)

- VENTING** - Each evaporator must have its own vent stack — A 6" vent pipe (HBG-15) and 10" vent pipe (HBG-30). The stack temperature will reach 450°F.

Recommended Materials:

- Class B Vent Pipe
- Stainless Steel Pipe
- Boiler Stacking

**NOTE:** If possible, the stack should be a single piece. However, if the stack has seams, the seams must be sealed with duct sealant to prevent moisture leaks; since the exhaust is water saturated. A tube of RTV silicone will be supplied with each machine shipped for this purpose. Moisture leakage may result in damage to the HBG electrical systems. All stack installations must be performed only by qualified personnel.

The top of the exhaust stack should be sufficiently high above the roof for proper dispersion of the exhaust. The stack should be unobstructed and in compliance with all local and federal codes. Avoid 90° bends in the stack. A straight stack is always best.

## GAS PRESSURE TEST

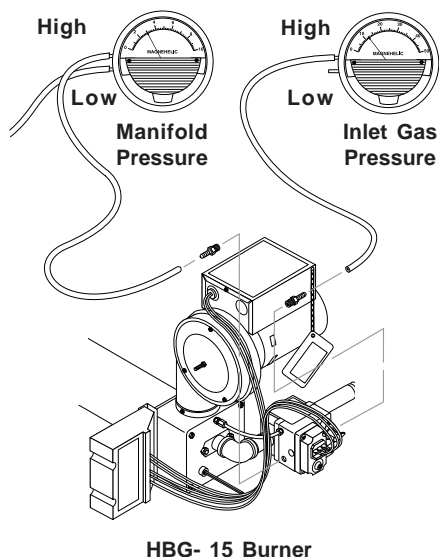

A vertical discharge design should be used, together with a vertical rain diverter. A conventional rain cap is not recommended for the HBG because of induced back pressure. A vertical rain diverter is an oversized piece of stack material that is concentric with the stack. The diverter extends 6" down over the top of the stack to allow flexibility in positioning fasteners. Both rain protection and back pressure reduction is achieved with this design. This type of rain diverter can be purchased from your local dealer.

7. **Air Requirements** - An air compressor capable of delivering a minimum of 4 cubic feet per minute (CFM) of air at 60-100 psi to work the optional auto fill air diaphragm pump and air assisted defoamer system. **NOTE:** Air supply must be on at all times for machine to operate.

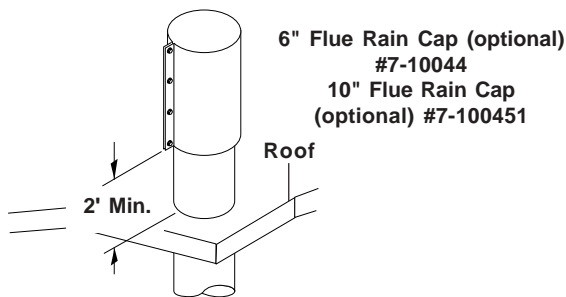

## PRE-START CHECK LIST

	YES	NO
Has gas supply been inspected by an authorized contractor to meet local codes?		
Has air supply hose been connected and adjusted?		
Is machine shielded from moisture or water spray?		
Is the voltage correct and are the circuit breaker and supply cord adequate according to specifications and serial plate notation?		
Is the machine electrically grounded?		
Is there ample wastewater supply?		
Have all flammable liquids or gases been removed from the installation location?		
Is there adequate gas supply for the BTU rating of the burner?		
Is incoming gas supply pressure to the machine between 6-14 w.c.i. or 1/2 psig?		
Has the proper gas regulator been installed for pressure and volume?		
Is the machine properly vented to allow adequate flow?		
Are the propane tanks large enough, according to the rating of the machine, to prevent freezing?		
Have gas lines been checked for gas leaks?		
Have all operators using this machine been instructed properly and have they read the manual?		
Has the machine been installed according to the operator's manual instructions?		
Has wastewater pH been adjusted between 8 - 10?		

**CAUTION:** If "NO" has been checked on any of the above questions, do not operate the machine.

## OPERATING INSTRUCTIONS

**NOTE:** If the waste stream being evaporated does not contain between 500-5000 mg/L of oil and you are using a mild steel tank, it is extremely important to add 1 quart of 20 to 40 weight chemical oil to the HBG-15 tank (2 quarts to the HBG-30 tank) each time maintenance is performed. This amount of oil will equal approx. 1/8" of oil on the top surface of the HBG liquid. This additive will impede corrosion. If this operation is not performed, the tank warranty will be void.

1. Supply the HBG-15/30 with 120 volts on a 15 amp service. **Note:** All supply voltage wires must be wired into the electrical box and connected to their respective terminal bar strip positions or grounding lugs. Refer to wiring diagram supplied with the machine.
2. Fill the evaporator tank with wastewater to the bottom of the top safety float. **Warning:** If the HBG liquid level is too high, the high level safety float will not allow the machine to operate.
3. Turn the fan switch to the ON position.  
**NOTE:** The fan switch must be on for any other components to operate.
4. If equipped with the optional auto fill air diaphragm pump, confirm the wastewater inlet line is connected to the inlet filter garden hose swivel connector.
5. Confirm that the external normally open float with the auto fill option in the wastewater holding tank is in the up position. If the float is in the down position when the pump switch is in the auto position, the pump will not operate. If the pump switch is in the manual position the external float will be bypassed.
6. Push the pump switch to the "auto" position (auto fill option). The pump will turn on, filling the tank with wastewater. The top float inside the tank turns the pump "off."
7. Turn gas control valve knob to "ON".
8. Push the burner switch to the "ON" position. If the low water float is in the up position the burner begins the ignition process.

**NOTE:** The low water float is controlled by a timer to alleviate the burner from being turned on and off due to boiling water agitation. When the low water float is moved from the down to the up position, the timer will initiate timing for 10 seconds before the burner is initiated.

The ignition process is as follows:

- A. **Trial for pilot ignition:** The flame module checks that a safe start flame simulating condition exists. A fan proving switch proves the burner fan is operating. If it is not operating, the burner will not ignite.
  - B. **Pilot ignition:** The flame module opens the gas pilot valve. Simultaneously, the electronic spark generator ignites the pilot. Once the pilot has ignition, the electronic spark generator turns off. The pilot ignitor/sensor rod proves there is flame at the pilot. If there is no flame at the pilot the burner goes into a safety lockout period.
  - C. **Main flame ignition:** Once the burner pilot sensor is proven the main gas solenoid valve opens allowing full burner operation. If the flame goes out, the pilot electronic spark generator attempts to re-ignite the pilot.
- NOTE:** If the burner does not ignite, confirm the gas solenoid valve on/off switch is in the "ON" position and that the manual reset high temperature switch has not tripped due to low water or high solids build up inside the HBG tank. The reset button is on the back of the control box.
9. Remove the plug at the gas solenoid valve manifold and install a hose barb fitting. Attach a 0-10" W.C. manometer. With the burner operating, adjust the regulator valve to the proper setting according to the chart below.
  10. When the predetermined batch cycle count has been reached and after maintenance has been performed, restart the machine by pushing the reset button on the batch cycle counter labeled F1/RST.
  11. To operate the optional oil skimmer, turn the burner to the "OFF" position allowing oil to float to the top of the tank. Lift the tank lid and attach the oil skimmer to the outer wall of the tank. Allow the stainless belt to pick up all the floating oil in the wastewater tank. Place a bucket under the downspout of the oil skimmer to collect the oil.

The evaporator will operate continuously until 1) the batch controller hits its predetermined number of batch cycles. 2) the water gets too low in the wastewater holding tank (auto fill option). 3) the water level in the wastewater tank causes the bottom float to trip off the burner. Once the liquid level float has risen, the burner will automatically restart.

## MAINTENANCE

**CAUTION:** Use protective gloves, goggles and any other protective clothing required by law for chemicals mixed with the waste stream.

The HBG does not require a lot of maintenance, but it does require consistent maintenance. The frequency of maintenance varies depending on what is in the water that is being evaporated.

General maintenance consists of removal of sludge from the bottom and removal of any floating oil at the top of the evaporation tank.

**WARNING** - Shut down the HBG and allow it to cool before performing any maintenance. Do not allow pump to run longer than 5 minutes without water. Disconnect all hoses to allow water to drain.

**OIL REMOVAL** - If you have excess floating oil in the evaporation tank liquid that needs to be removed, shut down the HBG and let the oil float to the top. Attach oil skimmer to side of tank and plug into own power source. Turn on the oil skimmer and collect oil in a bucket.

**SLUDGE REMOVAL** - Remove the lower 3" sludge drain cap on the side of the evaporator allowing sludge and water to escape. Use a small shovel to remove the residual sludge from the bottom of the tank. Removing the sludge and cleaning the floor of the evaporator will greatly improve the evaporation rate.

**NOTE:** Allowing sludge to accumulate on the floor of the HBG can cause warpage, corrosion and or heat stress to the floor. A build-up of solids will cause the manual reset high temperature switch to trip not allowing the burner or pump to operate. Remove the sludge, refill the tank and restart the machine.

**WARNING:** Allowing sludge to build up on the inside floor of the HBG can cause warpage to the floor of the tank and will void the warranty.

**DRAFT INDUCER:** On a monthly maintenance schedule, cleaning of the fan blade fins and exhaust stacking must be done to remove any sludge build-up that can reduce the evaporation efficiency. To clean the fan blade fins, start with the water cool and the fan switch on the control panel in the off position. Next, remove the six tek screws that attach the fan to the stack. Pull the inducer

fan away from stack and scrape debris from blade fins. On reassembly, place a small bead of high heat silicone around the outer edge of the inducer housing on each tek screw to seal out any possible air leaks.

## WEEKLY MAINTENANCE

1. Turn all power switches to the "OFF" position.
2. Allow the wastewater to cool.
3. Position a sludge container under the sludge valve. Open the sludge valve and remove the remaining waste liquid.
4. After every complete batch, scrape the floor and interior walls of the HBG tank, transferring the sludge into the sludge container.
5. Remove any buildup that has accumulated on the exterior of the tank and exhaust pipe.
6. Clean the liquid level floats, remove any accumulation that may coat the floats and not allow them to move more freely.
7. Clean the screen of the wastewater filter if auto fill is installed on the machine.
8. If the evaporator is not in use at least twice per week, then clean out and rinse with fresh water, and let sit empty.
9. Check tank and lid for corrosion after each complete batch.

## SEMI ANNUAL MAINTENANCE

1. Check auto fill pump for proper pressure, flows and electrical capacities.
2. Check auto fill floats for proper operation.
3. Oil the draft inducer motor bearings. Oil holes are provided at front and rear faces of motor. **Caution:** Not more than 3 drops of S.A.E. 20 oil should be used.
4. Check tank and lids for corrosion.
5. Check burner for proper operation and gas pressure.

HBG FUEL AND AIR SETTINGS					
Natural Gas	GPH	Gas Oriface	Inlet Gas Supply Pressure	Man. Pressure	Air Setting
HBG-15D	10 - 15	G (.261)	4.5 - 14 WCI	3.5 WCI	Open Draft Wheel 6 Full Turns
HBG-30D	25 - 30	15/32	5.5 - 14 WCI	4.0 WCI	Draft Open to 4
Liquid Propane	GPH	Gas Oriface	Inlet Gas Supply Pressure	Man. Pressure	Air Setting
HBG-15D	10 - 15	#22 (.157)	11 - 14 WCI	10 WCI	Open Draft Wheel 6 Full Turns
HBG-30D	25 - 30	Q - (.332)	5.5 - 14 WCI	3.75 WCI	Draft Open to 4

## AUTO FILL OPERATING CHARACTERISTICS

The auto fill option consists of two level control switches which control the fill pump. The lower level switch turns the pump on. As the water level raises, the upper level switch turns the pump off. The evaporator then evaporates the water, which in turn lowers the water level past the lower level switch, which turns the pump on and starts the fill process.









**Note:** To engage the auto fill feature, push the pump switch to auto. This will allow the pump to be controlled by the auto fill float level switches. Pushing the pump switch to manual will bypass the external N/O tethered float in the wastewater holding tank.

## AIR ASSISTED DEFOAMER OPERATING CHARACTERISTICS

The air assisted defoamer option consists of a metering pump drawing up defoamer and a solenoid controlling the air injecting the defoamer through a fan nozzle located inside the wastewater tank. Set the three position switch to "auto" and defoamer will then be injected every time the machine refills. If more defoamer is needed, turn adjustment screw, located behind white cap in front of pump, clockwise to increase pump speed. Injecting manually is also available. **NOTE:** The air pressure needed to operate the defoamer must not exceed 2 psi.



# Batch Cycle Counter Quick Reprogramming Instructions

1. Pull face plate of batch cycle counter out of its holder in electrical box with your fingers . Dip switch #7, located along left side (wall) of circuit board, needs to be switched to the down (OFF) position. This will allow for reprogramming. Slide batch counter back into its holder.
2. Press  button until LED screen in green shows (  $PRS_1$  #02 ). Push the  or  button until the new batch cycle count appears in green. Then press the  button once to save the setting for preset 1.
3. Press  button once more. The LED screen in green will show (  $PRS_2$  #02 ). Push the  or  until the value in green is the same value in preset 1. Press  button to save setting for preset 2.
4. Remove batch cycle counter once again from its holder in the electrical box. Change the setting on dip switch #7 to the up (ON) position. Slide the batch counter back into its holder in the electrical box.

**NOTE:** # stands for batch count value

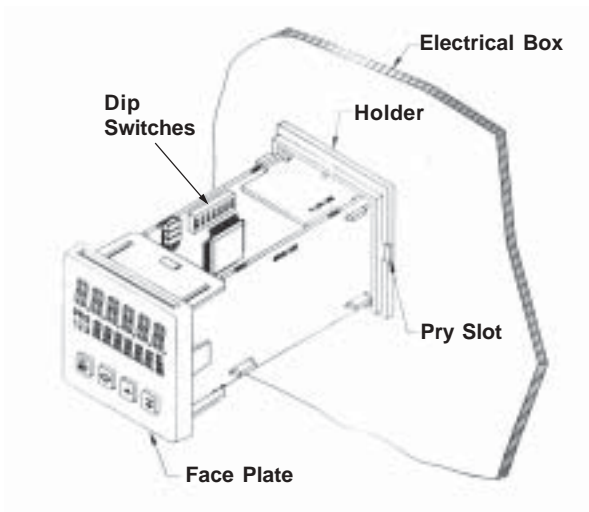

## Function Settings



**Reset Button.** Push to restart machine after batch cycle completed.



**Scroll Button.** Push to select the different programming modes. Also saves program values.



**Vertical Scroll** changes programming values.



**Horizontal Scroll** for multiple values. Also changes programming values.

## INITIAL PROGRAMMING OF BATCH CYCLE COUNTER

### Function Settings

**Reset Button.** Push to restart machine after batch cycle completed.

**Scroll Button.** Push to select the different programming modes. Also saves program values.

**Vertical Scroll** changes programming values.

**Horizontal Scroll** for multiple values. Also changes programming values.

**NOTE: Original batch counter has been preset at factory.**

### Programming

1. Press and hold **↻** button for 2 seconds. **(Entry)** will appear in red. **(Auto Sc)** will appear in green. No change is necessary.

2. Press **↻** button once, **(Ac PSc)** will appear in red. **(-L)** will appear in green and does not need to be changed.

3. Press **↻** button, **(PSc ALr)** will appear in red. **(1.00000)** will appear in green and does not need to be changed.

4. Press **↻** button, **(dEc Pt)** will appear in red. **(-----)** will appear in green. This value can't be changed.

5. Press **↻** button, **(Cnt In)** will appear in red. **(Cl-ud)** will appear in green. No change is necessary.

6. Press **↻** button, **(OPEr 1)** will appear in red. **(11)** will appear in green. Press **▼** button until **(1)** is showing.

7. Press **↻** button, **(C2 ASn)** will appear in red. **(bAtch)** will appear in green. No change is necessary.

8. Press **↻** button, **(OPEr 2)** will appear in red. **(1)** will appear in green. No change is necessary.

9. Press **↻** button, **(Ac PrS)** will appear in red. **(-y-y-y)** will appear in green. Press **▼** button until the far left **(-y)** value is blinking. To change, press **▲** button until **(-L)** is showing. Press **▼** once, the middle **(-y)** value will blink. Press **▲** button until **(-n)** is showing. Press **▼** button once more and the far right **(-y)** will blink. Press **▲** button until **(-n)** is showing.

10. Press **↻** button, **(PrESEt)** will appear in red. The value to set is predetermined from the wastewater analysis. This value is known as PRS1 (Preset 1). Press the **▲** or **▼** buttons to set the batch cycle value.

11. Press **↻** button, **(PrESEt)** will appear in red. This value, PRS2 (preset 2), must be set with the same value as (preset 1). Press the **▲** or **▼** buttons to set value.

12. Press **↻** button, **(PrESEt)** will appear in red. This is (preset 3) and must be set with the value **999999**. Press and hold the **▲** button until achieved.

13. Press **↻** button, **(P1tr Ac)** will appear in red. Value **(no)** will appear in green. No change is necessary.

14. Press **↻** button, **(Ac Out)** will appear in red. **(-L-L-L)** will appear in green. No change is necessary.

15. Press **↻** button, **(OutrES)** will appear in red. **(0.01SEC)** will appear in green. No change is necessary.

16. Press **↻** button, **(OutPut)** will appear in red. **(1t 0.10)** will appear in green. No change is necessary.

17. Press **↻** button, **(OutPut)** will appear in red. **(2t 0.10)** will appear in green. No change is necessary.

18. Press **↻** button, **(OutPut)** will appear in red. **(3t 0.10)** will appear in green. No change is necessary.

19. Press **↻** button, **(rEUOut)** will appear in red. **(-n-n-n)** will appear in green. Press **▼** button until middle **(-n)** value is blinking. Press **▲** button until **(-y)** value is showing.

20. Press **↻** button, **(rEUAnu)** will appear in red. **(-n-n-n)** will appear in green. No change is necessary.

21. Press **↻** button, **(OutP.uP)** will appear in red. **(PPP)** will appear in green. Press **▼** button until left **(P)** value is blinking. Press **▲** button until **(P)** value appears. Do the same for center and right, all values should read **(-P)**

22. Press **↻** button, **(USr In 1)** will appear in red. **(rSt. -L)** will appear in green. Press **▲** button until **(Pro.dis)** appears.

23. Press **↻** button, **(USr FI)** will appear in red. **(rst-L)** will appear in green. No change is necessary.

24. Press **↻** button, **(CodE)** will appear in red. Value **(0)** will appear in green. No change is necessary.

25. Press **↻** button, **(ScroLL)** will appear in red. **(no)** will appear in green. No change is necessary.

26. Press **↻** button, **(FAcSEt)** will appear in red. **(no)** will appear in green. No change is necessary.

27. Press and hold **↻** button for 2 seconds. **(Prog)** will appear in red and **(SAVE)** will appear in green.

To complete setting the batch counter, first pull the face plate of the batch counter out of its holder with your fingers. This will expose the internal circuit boards. Along the left side (wall) circuit board are the dip switches. These switches are numbered 1 through 7. Switches 2, 5, and 7 need to be in the up (ON) position.

Slide the batch counter back into its holder. Initial programming of the batch cycle controller is now complete.

**(NOTE: Programming cannot be performed if dip switch #7 in the up (ON) position). If adjustment to the batch cycle count value is to be reprogrammed, dip switch #7 needs to be in the down (OFF) position. When reprogramming is complete, set dip switch #7 back to the up (ON) position.**



<b>SETTINGS CHART</b>	
<b>MODE</b>	<b>VALUE SETTING</b>
Entry	Auto Sc
Ac PSc	-L
PSc ALr	1
dEc In	-----
Cnt Pt	CI-ud
OPEr 1	1
C2 ASn	bAtch
OPEr 2	1
Ac PrS	-L-n-n
PrESEt	Customer batch cycle value
PrESEt	Customer batch cycle value
PrESEt	999999
PltrAc	no
Ac Out	-L-L-L
OutrES	0.01SEC
OutPut	1t 0.10
OutPut	2t 0.10
OutPut	3t 0.10
rEUOut	-n-y-n
rEUAnu	-n-n-n
OutP.uP	-P-P-P
USr Inl	Pro.dis
USr FI	rst-L
codE	0
Scroll	no
FacSEt	no
Dip switches 2, 5, 7 are set in up (ON) position	

## INSTALLATION DIMENSIONS

HBG-15 HBG-30

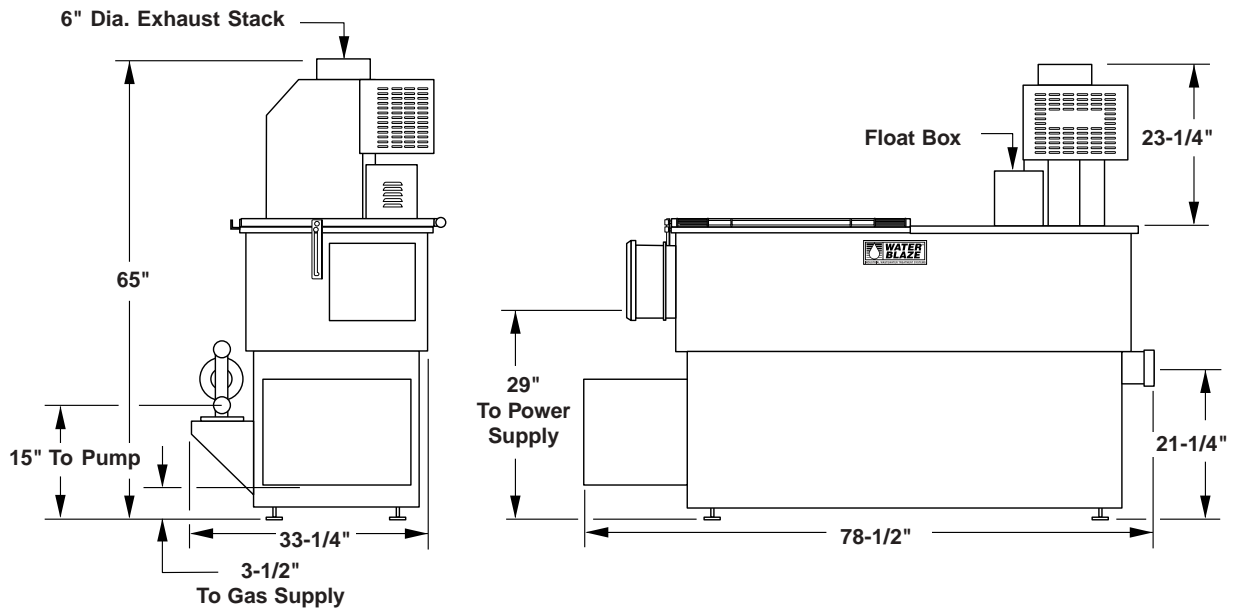

HBG-15

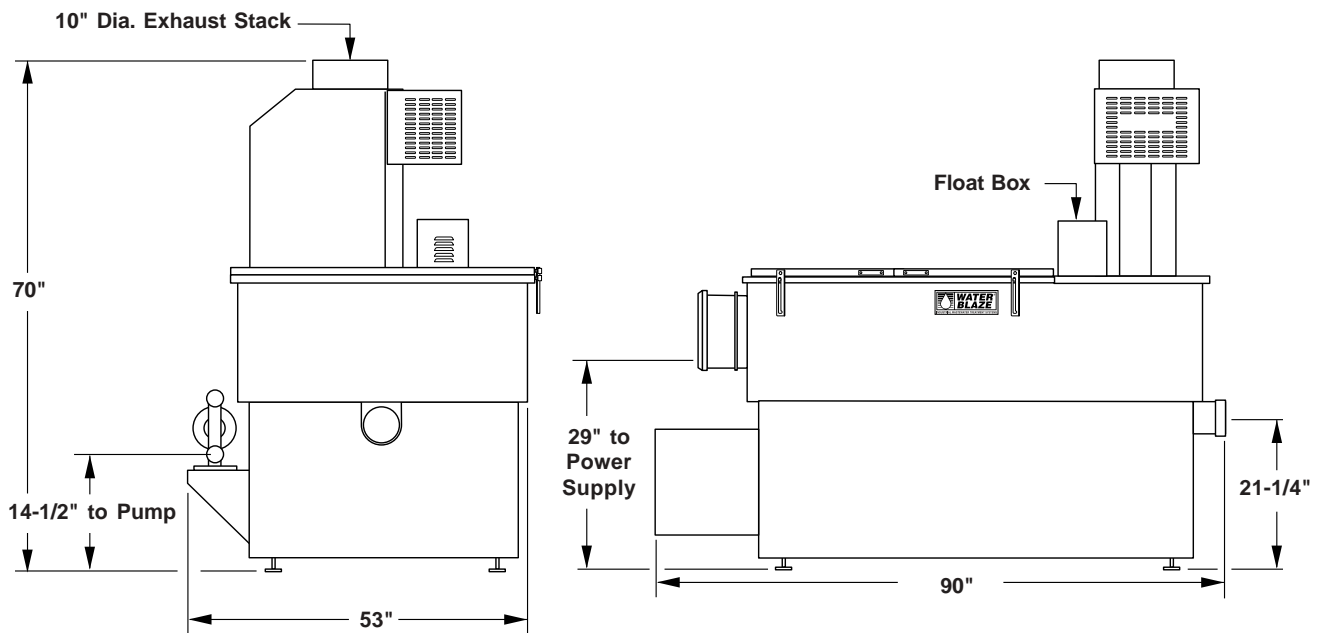

HBG-30

**EXPLODED VIEW**  
**LEFT SIDE • HBG-15**

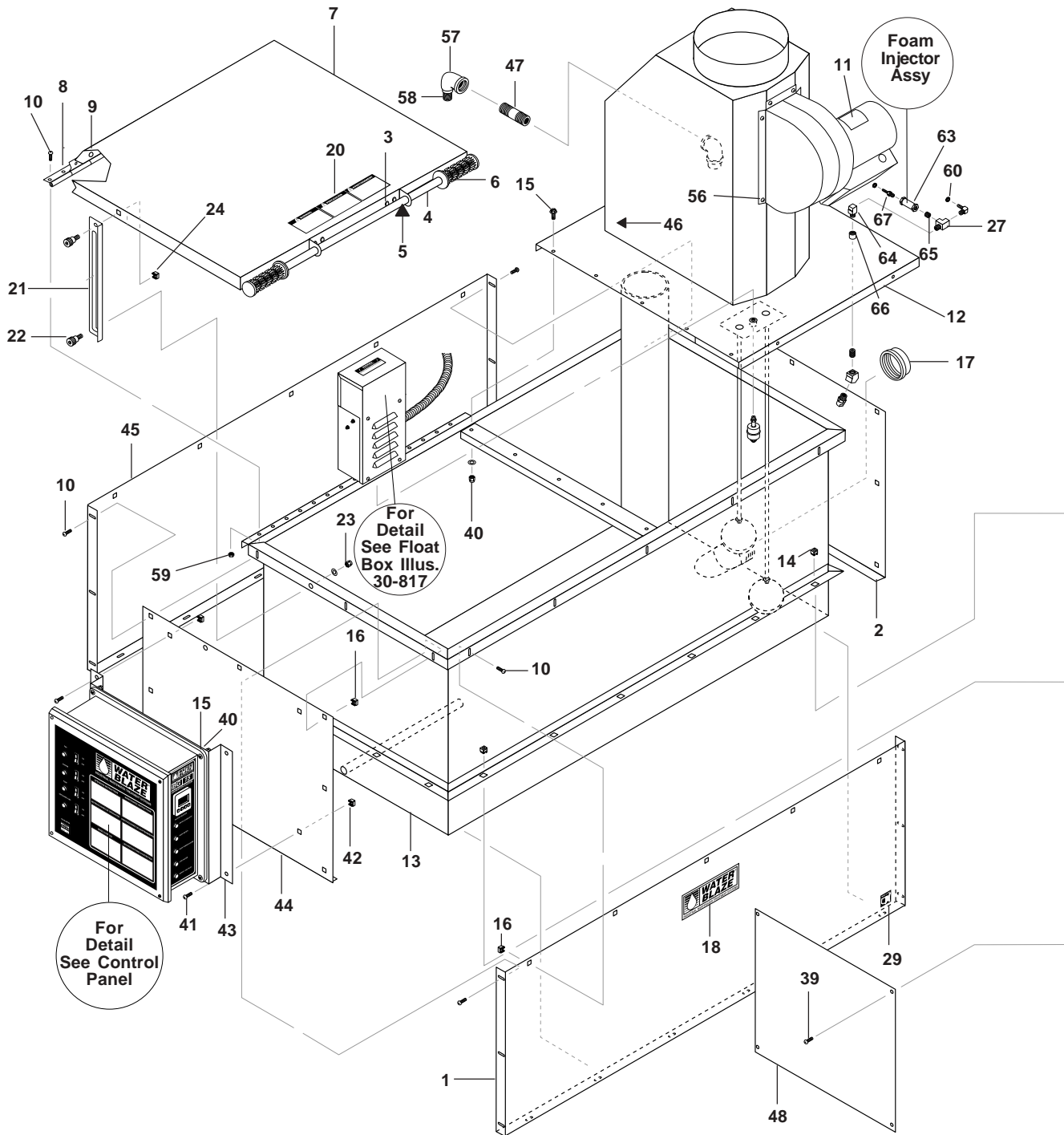

## EXPLODED VIEW RIGHT SIDE • HBG-15

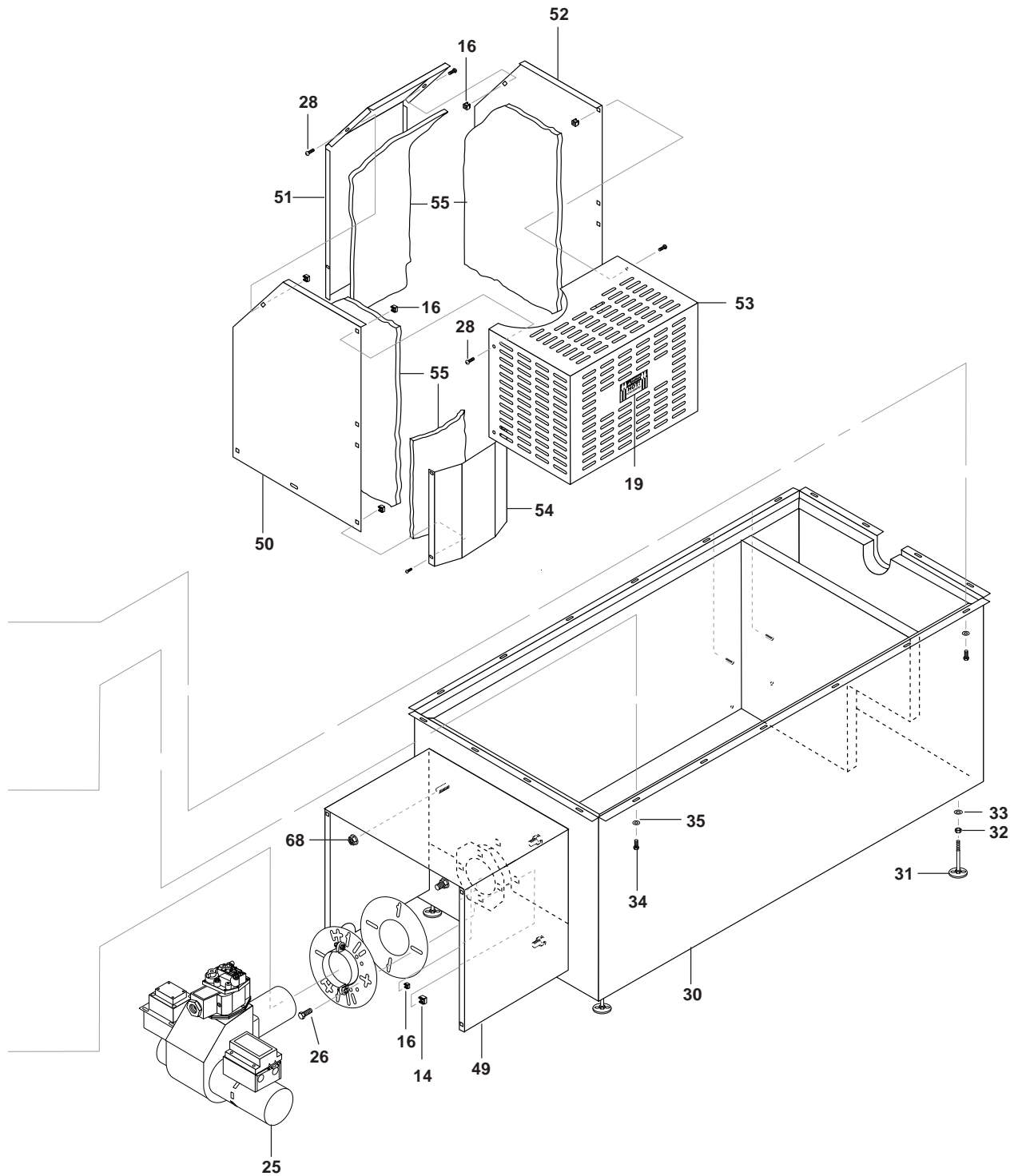

## HBG-15 EXPLODED VIEW PARTS LIST

ITEM	PART NO.	DESCRIPTION	QTY	ITEM	PART NO.	DESCRIPTION	QTY
1	95-074303	Panel, Front	1	26	90-1016	Bolt, 3/8" x 1", NC, H	3
2	95-074304	Panel, Left Side	1	27	2-1037	Tee, 1/4" Branch, Male	1
3	95-074000951	Bracket, Handle	1	28	90-10141	Screw, 10/32" x 1/2" SS	14
4	95-07400095	Pipe, 1/2" X 32.5"	1	29	10-08014	Label, Made in USA	1
5	2-01404	▲ Snap Bushing, 7/8"	2	30	95-074301	Fire Box W/Insulation	1
6	2-01102	Grip, 7/8"	2		7-014842	▲ Insulation, 1" x 2"	15 ft.
7	95-074000961	▲ Lid, Top Inside Shell, 316L SS	1	31	95-07700011	Leveling, Foot Assembly	4
	95-07400097	Lid, Hinged Outside Shell	1	32	90-20082	Nut, 1/2" Hex	4
	7-0137	▲ Insulation, Rigid Foam, 1/2"	2.5 ft.	33	90-40091	Washer, 1/2" Lock	4
	2-4037	▲ Pad, HBG Lid, 1/4"	2	34	90-10162	Bolt, 3/8" x 1", NC HH SS	20
8	90-50203	Hinge, 2" x 36" Piano, Stainless	1	35	90-4002	Washer, 3/8"	20
9	90-4999	Rivet, 1/4" x 3/8" Grip, Blind SS	15	36	90-4001	▲ Washer, 5/16"	4
10	90-19995	Screw, Cap 10/32" x 3/4" BH, HF, SS, Soc	57	37	10-02023	▲ Label, Liquid Propane	1
11	5-1511	Fan, Draft Inducer, D-3	1		10-02024	▲ Label, Natural Gas	1
12	95-074302	Panel, Top, 316L SS	1	38	90-2002	▲ Nut, 3/8" ESNA	4
	7-100432	▲ Flue Adapter, 6"	1	39	90-1991	Screw, 10/32" x 1/2", BHSOC	4
13	95-074300	Tank Assembly, Carbon Steel	1	40	90-2000	Nut, 1/4" ESNA	9
	95-0743001	Tank Assembly, 316L SS	1	41	90-1006	Bolt, 5/16" x 3/4"	4
	95-0743002	Tank Assembly, AL-6XN SS	1	42	90-2023	Nut, 5/16" x 12 Gauge, Black	1
	95-074135	▲ Shovel, Clean Out	1	43	95-074309	Standoff, Electric Box	1
14	90-2020	Nut, Cage, 3/8" x 12 Gauge	23	44	95-074128	Panel, Right Side	1
15	90-1802	Screw, 1/4"-20 x 3/4" Phil PH SS M/S	9	45	95-074305	Panel, Rear	1
16	90-2018	Nut, Cage, 10/32" x 16 Gauge	100	46	2-001338	▲ Nipple, 1" x 4", 316L SS	1
17	2-004984	Pipe, Cap, 3" Black Pipe	1	47	2-00134	Nipple, 1" x 4"	1
	2-0049841	Pipe, Cap, 3", 316LSS	1	48	95-074308	Lid, Burner Cover	1
	2-30047	▲ Valve, 3" Brass, Ball (Optional)	1	49	95-074306	Cover, Burner Assembly	1
18	10-9009	Label, Landa WATER BLAZE System	1	50	95-074817	Side Panel, Left, Plenum	1
19	10-02025A	Label, Hot/Caliente	3	51	95-074820	Cover, Plenum	1
20	10-50182	Label, Steam Warning	1	52	95-074818	Side Panel, Right, Plenum	1
21	95-074133	Support, Lid Lock, HBG	1	53	95-074821	Cover, Fan Shield	1
22	90-10151	Bolt, 3/8" Shoulder	2	54	95-074819	Lower Cover, Plenum	1
23	90-2001	Nut, 5/16" ESNA	5	55	7-0143	Insulation, Blanket - No Foil, 1/2" x 24"	6
24	90-2021	Nut, Cage, 5/16" x 16 Gauge	1	56	90-30011	Screw, #12 x 3/4", TEK	6
25	7-00045	Burner, P-250 AFEP, NG	1	57	2-00295	Elbow, 1" x 3/4", Reducing	1
	7-00047	Burner, P-250 AFEP, LPG	1	58	2-00151	Nipple, 3/4" Close	1
				59	90-017	Nut, 10/32" Keps	15
				60	2-9040	Clamp, Hose	3
				61	6-02177	▲ Elbow, Hose Barb, 1/4" Barb x 1/4" Pipe	2

## HBG-15 EXPLODED VIEW PARTS LIST (CONTINUED)

ITEM	PART NO.	DESCRIPTION	QTY
62	2-1059	▲ Nipple, 3/4" x 1/2" Pipe	1
63	2-3070	Valve, 1/4" Check	1
64	2-1022	Elbow, 1/4" Street	1
65	2-1002	Nipple, 1/4" Close	1
66	2-00265	Elbow, 1/4" Street	1
67	2-1089	Hose Barb, 1/4" Barb x 1/4" Pipe	3
68	90-20040	Nut, 3/8" Whiz Loc	4

## EXPLODED VIEW LEFT SIDE • HBG-30

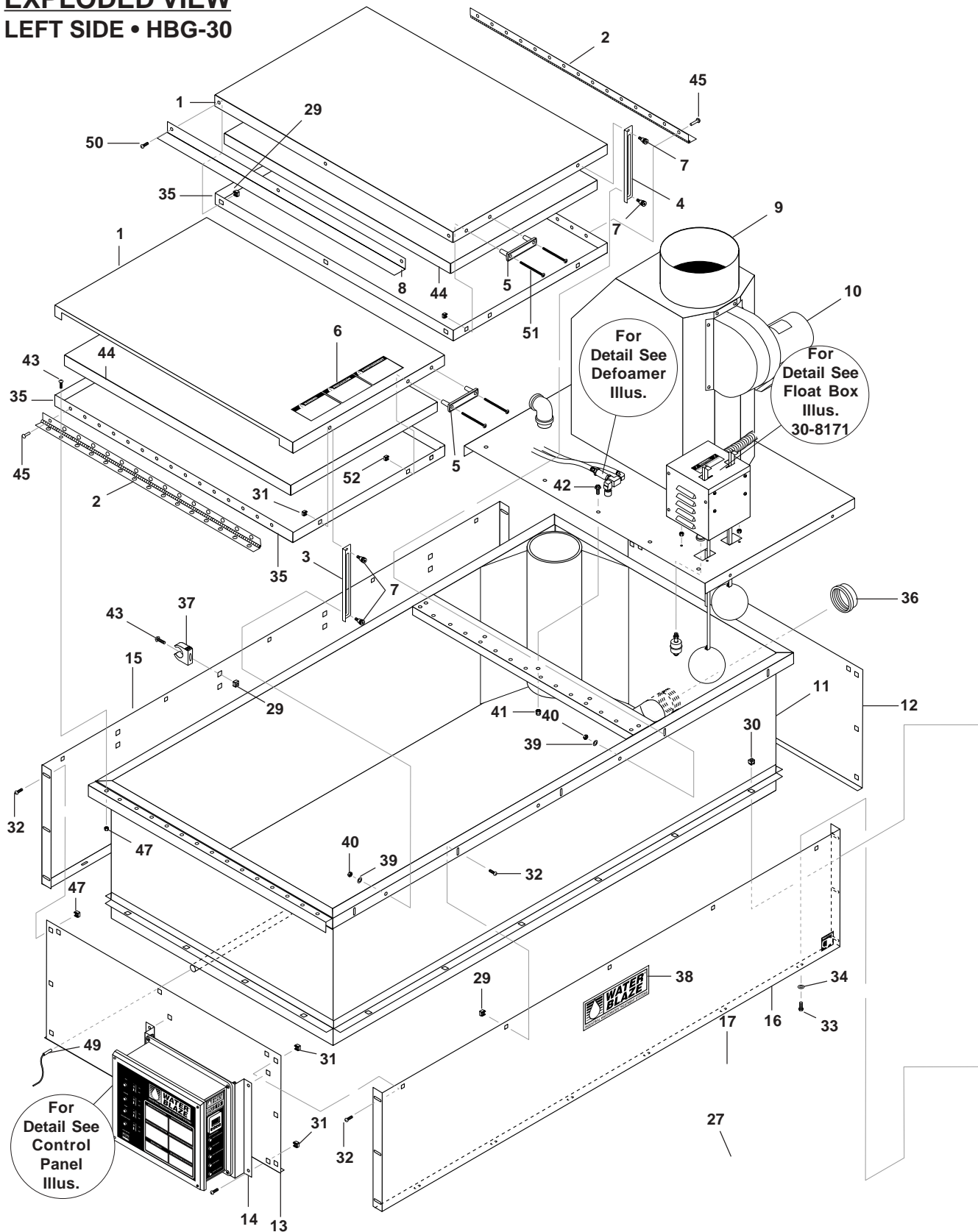



## EXPLODED VIEW RIGHT SIDE • HBG-30

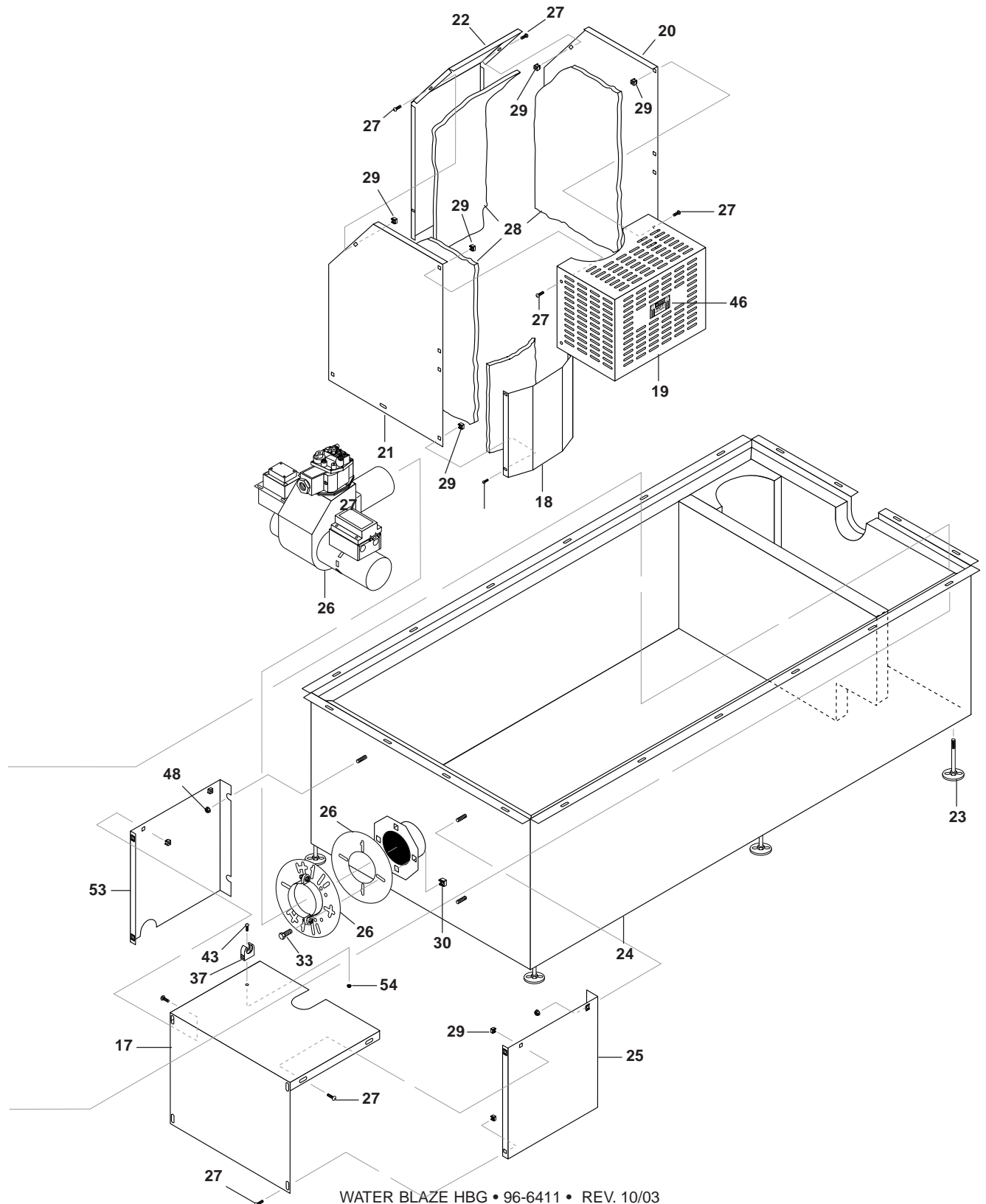

**HBG-30 EXPLODED VIEW  
PARTS LIST**

ITEM	PART NO.	DESCRIPTION	QTY	ITEM	PART NO.	DESCRIPTION	QTY
1	95-074803	Lid, Top	2	25	95-074835	Wall, Burner Cover, Left	1
2	90-50203	Hinge, 2" x 72" Piano, Stainless	2	26	7-00046	Burner, Wayne, HSG-400	1
3	95-074133	Support, Lid, HBG	1	27	90-1991	Screw, 10/32" x 1/2" BHSOC	12
4	95-074808	Support, Lid	1	28	7-0143	Insulation, Blanket, No-Foil, 1/2" x 24"	8
5	2-01194	Handle, Lid SJ	2	29	90-2018	Nut, Cage, 10/32" x 16 Gauge	56
6	10-50182	Label, Steam Warning, Hot Box	1	30	90-2020	Nut, Cage, 3/8" x 12 Gauge	24
7	90-1992	Screw, 3/8" x 3/8", SCKT, SHDR	4	31	90-2023	Nut, Cage, 5/16" x 12 Gauge	5
8	95-074804	Guard, Splash	1	32	90-1802	Screw, 1/4"-20 x 3/4" Phil, PH, SS	12
9	95-074808	Assy, Top Panel	1	33	90-10162	Bolt, 3/8" x 1" HH/NC, 316 SS	18
	7-100433	Adapter, Flue, 10"	1	34	90-30991	Washer, 3/8" S/S Flat	18
10	5-1511	Fan, Draft Inducer D-3,	1	35	95-074801	Lid, Bottom, 16 Gauge 316L	2
11	95-074800	Assy, Tank, Carbon Steel	1	36	2-004984	Cap, Pipe, 3" Black Pipe	1
	95-0748001	Assy, Tank 316L SS	1		2-0049841	Cap, Pipe, 3" 316L SS	1
	95-0748002	Assy, Tank, AL-6XN	1		2-30047	▲ Valve, 3" Brass (Optional)	1
	95-074135	▲ Shovel, Clean-Out	1	37	2-9013	Clip, Conduit	9
12	95-074832	Panel, Drain End	1	38	70-9009	Label, Landa Wastewater Evaporator	1
13	95-074831	Panel, Burner End	1	39	90-4001	Washer, 5/16" Flat	8
14	95-074307	Bracket, Electrical Box	1	40	90-2001	Nut, 5/16" ESNA	2
15	95-074830	Panel, Rear	1	41	90-20001	Nut, 1/4" ESNA, SS	5
16	95-074833	Panel, Front	1	42	90-1802	Screw, 1/4"-20 x 3/4" Phil, PH, SS, M/S	5
17	95-074837	Top, Burner Cover	1	43	90-19995	Screw, Cap, 10-32 x 3/4"	53
18	95-074814	Lower Cover, Plenum Heat Shield	1	44	7-0137	Insulation, Rigid Foam, 1/2"	1
19	95-074816	Cover, Fan Shield	1	45	90-4999	Rivet, 1/4" x 3/8" Grip, Blind SS30	
20	95-074813	Panel, Right Side	1	46	10-02025A	Label, Hot/Caliente	1
21	95-074812	Panel, Left Side	1	47	90-020	Nut, 10-32, SS	46
22	95-074834	Cover, Plenum	1	48	90-20040	Nut, 3/8" Whiz Loc	4
23	95-07700011	Foot, Leveling	5	49	4-050838	Thermocouple, SS Sheath, 34"	1
24	95-07105010	Assy, Fire Box	1	50	90-19996	Screw, 10-23 x 1/2" BH, SOC SS	6
				51	90-1044	Screw, 1/4"-20 x 2" SHCS, Zinc	4
				52	90-2022	Nut, Cage, 1/4" x 16 Gauge	4
				53	95-074836	Wall, Burner Cover, Right	1
				54	90-017	Nut, 10-32 Keps	1

▲ Not Shown

## CONTROL PANEL

### HBG-15, HBG-30 Exploded View and Parts List

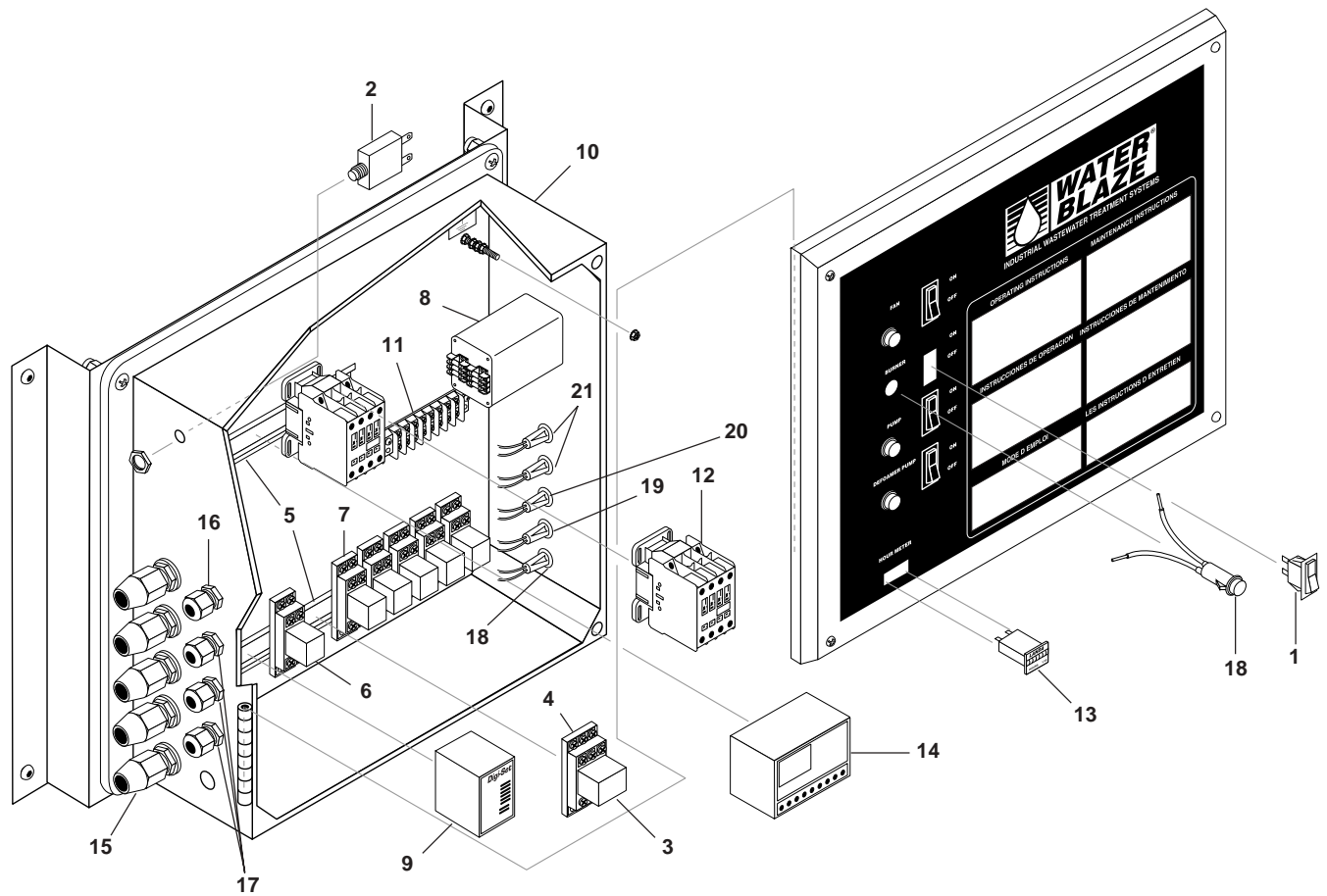

ITEM	PART NO.	DESCRIPTION	QTY
1	6-020251	Switch, Curvette	4
2	6-0205	Switch, Momentary Push	1
3	6-03522	Relay, 120V, 4PDT	1
4	6-035221	Base, Relay, 120V, 4PDT	1
5	6-021595	Din Rail, 35MM	19"
6	6-03621	Relay, 120V, 2PDT	5
7	6-03541	Base, Relay, 2PDT	5
8	6-03676	Counter, Red Lion	1
9	6-03721	Timer, Variable Time	1
10	6-03913	Box, Plastic, 14" x 16" x 6-3/4" w/Hinged Lid	1
11	6-05040	Block, Terminal, 8 Pole	1
12	6-4000	Contacting, 120V, CH	1

ITEM	PART NO.	DESCRIPTION	QTY
13	4-050822	Hour Meter, 115/240VAC	1
14	4-050842	Hi Limit Control, ETR-3-02	1
15	6-05159	Connector, 1/2" LT	5
16	6-05153	Strain Relief, STRT, LQ Tite	1
17	6-05152	Strain Relief, STRT, LQ Tite Sm	3
18	6-020530	Light, Indicator, Green, 125V	3
19	6-050413	Light, Amber, 125V	1
20	6-050418	Light, Blue, 14V	1
21	6-050416	Light, Blue, 125V	2

## FLOAT ASSEMBLY HBG-15 EXPLODED VIEW 30-817

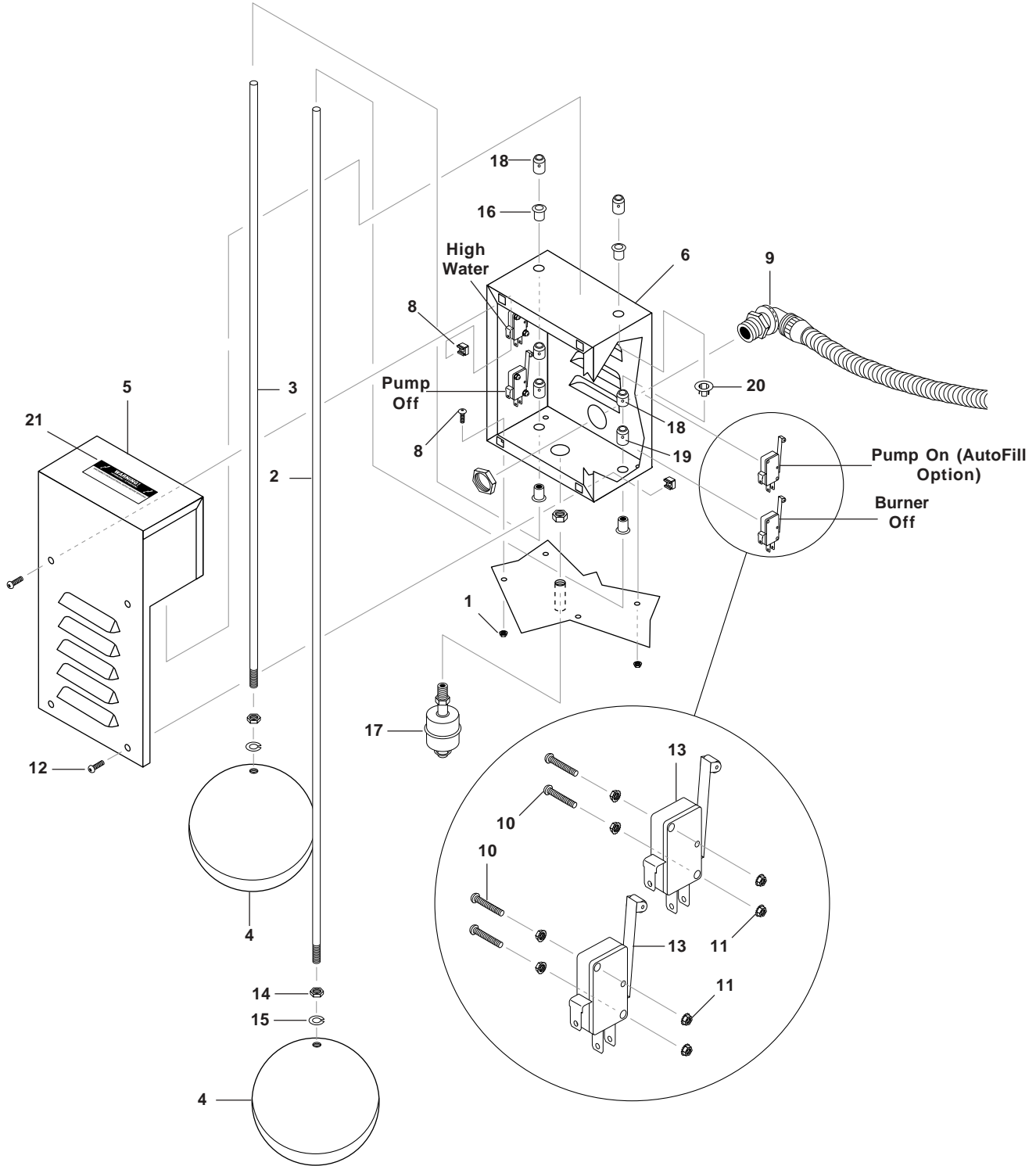

## FLOAT ASSEMBLY HBG-15 PARTS LIST

ITEM	PART NO.	DESCRIPTION	QTY
1	90-020	Nut, 10/32" NF ST KEP	4
2	95-074160	Rod, Float, 1/4" x 23"	1
3	95-074161	Rod, Float, 1/4" x 15.5"	1
4	4-0490	Float, 3-1/2" Ball, Steel	2
5	95-074162	Cover, Liquid Level Switch	1
		▲ Label, Keep Floats Free of Debris	1
6	95-074163	Housing, Liquid Level Switch	1
7	90-2018	Nut, Cage, 10/32" x 16 Gauge	4
8	90-1991	Screw, 10/32" x 1/2" BH SOC, Black	4
9	6-051599	Connector, 90°, Black	1
10	90-128	Screw, 4"-40 x 3/4", Slotted P/H M/S, Zinc	8
11	90-20042	Nut, 4"-40 Keps, Zinc	16
12	90-19995	Screw, 10/32" x 3/4" BH SOC, SS	4
13	6-0801	Switch, Micro, V3L1101D8, Roller Level	4
14	90-20055	Nut, 1/4"-20, SS	2
15	90-40008	Washer, 1/4" Split, SS	2
16	2-0167	Bearing, Plastic	4
17	6-03941	Switch, Liquid Level, SS, N/C	1
18	90-200415	Collar, Shaft, Small	4
19	90-200416	Collar, Shaft, Large	2
	90-3015	Set Screw, 8/32" x 1/8"	6
20	90-4014	Washer, 7/16", Self-Locking Retaining Wing	2
21	10-08021	Label, Disconnect Power Supply	1

▲ Not Shown

**FLOAT ASSEMBLY**  
**HBG-30 EXPLODED VIEW**

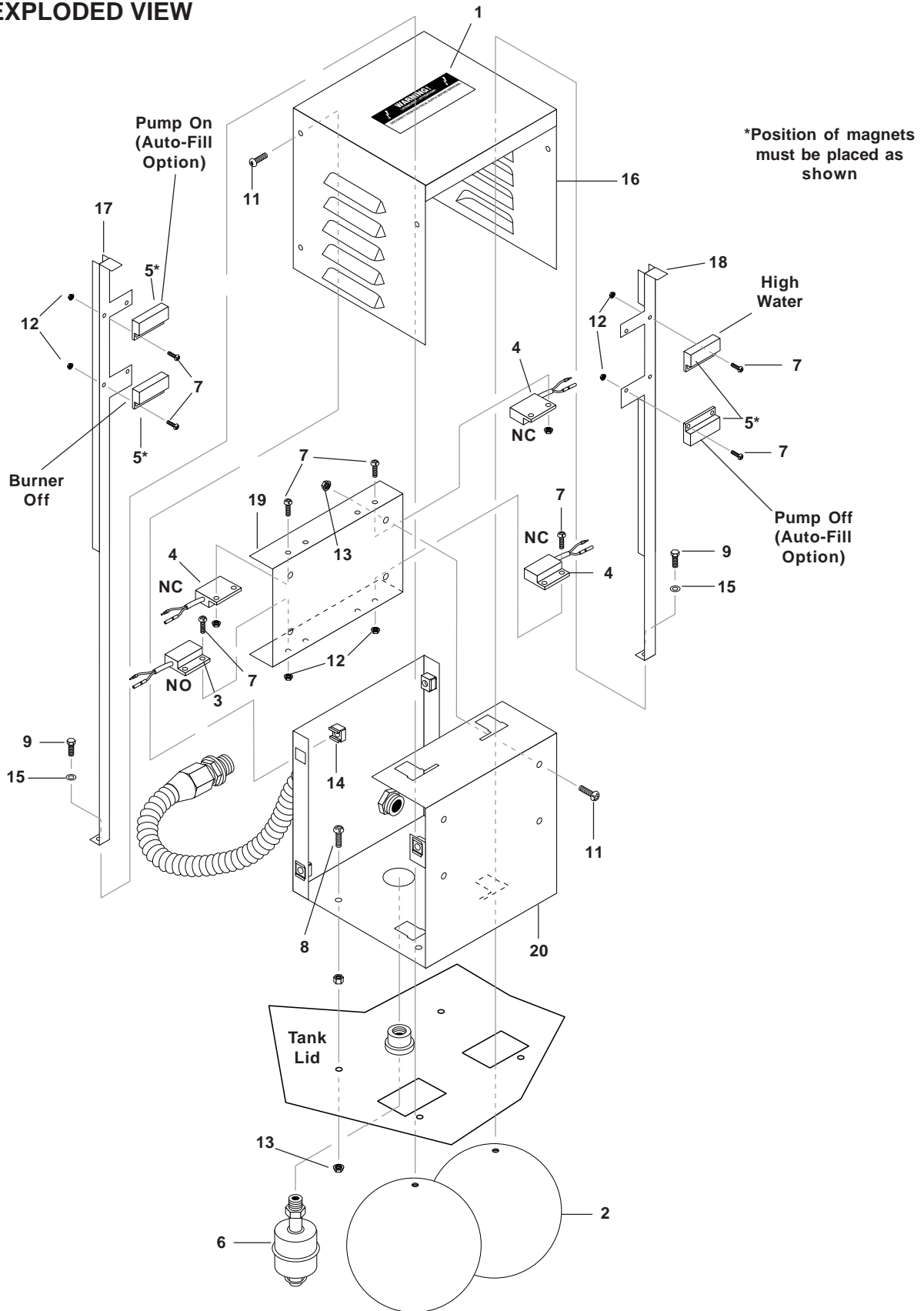

## FLOAT ASSEMBLY HBG-30 PARTS LIST

ITEM	PART NO.	DESCRIPTION	QTY
1	10-5013	Label, WB, Keep Floats Free	1
2	4-0490	Float, 3-1/2" Ball, Steel	2
3	6-02074	Switch, Magnetic Reed, NO	1
4	6-02075	Switch, Magnetic Reed, NC	3
5	6-02076	Magnet, Reed Switch	4
6	6-03941	Switch, Liquid Level	1
7	90-127	Screw, 4"-40 x 1/2"	16
8	90-19996	Screw, 10/32" x 1/2"	4
9	90-18061	Screw, 1/4" x 1/2", 7, 316L	2
10	90-18062	Screw, 10/32" x 1/2"	2
11	90-19995	Screw, 10/32" x 3/4"	6
12	90-20042	Nut, 4-40 Keps	16
13	90-020	Nut, 10/32" SS	4
14	90-2018	Nut, Cage, 10/32" x 16 Gauge	6
15	90-40008	Washer, 1/4" Split Ring Lock	2
16	95-074809	Lid, Float Box	1
17	95-074825	Rod, Float, Long	1
18	95-074826	Rod, Float, Short	1
19	95-074827	Plate, Switch Mount	1
20	95-074828	Box, Float	1

▲ Not Shown



**HBG OPTIONS**  
**AUTO FILL EXPLODED VIEW**

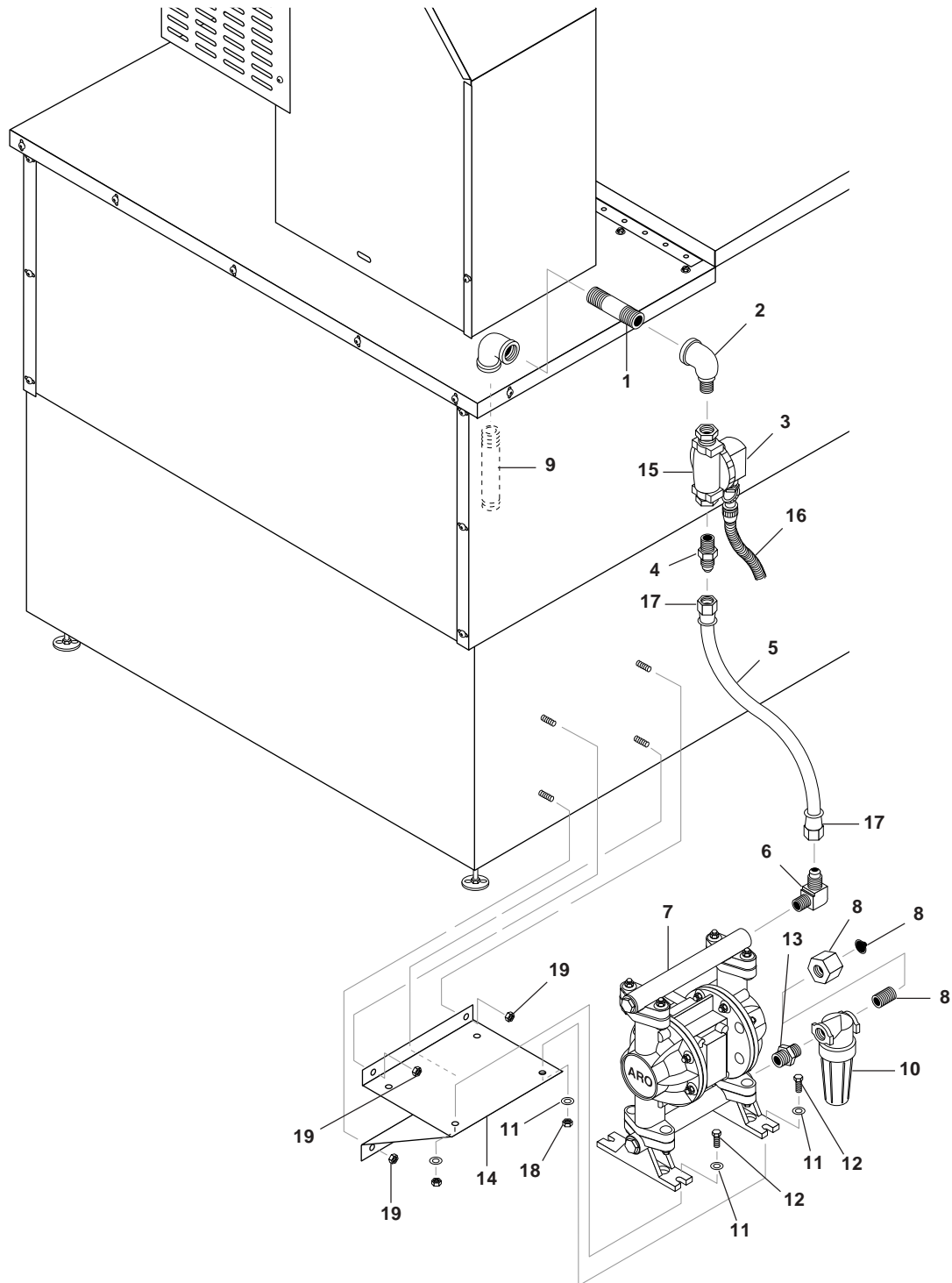

## HBG OPTIONS

### AUTO FILL PARTS LIST

ITEM	PART NO.	DESCRIPTION	QTY
1	2-00134	Nipple, 1" x 4", Black Pipe	1
2	2-00295	Elbow, 1" x 3/4", Reducing Blk	1
3	6-140160	Solenoid Coil, 120V	1
4	2-10636	Nipple, 3/4" JIC x 3/4" Pipe	1
5	4-02120000	Hose, 3/4" Push-On	1.66 ft.
6	2-10630	Elbow, 3/4" JIC x 1/2", 90°	1
7	5-1951	Pump, Air Diaphragm, 1/2" Poly1	
8	2-1902	Strainer, Inlet Garden Hose	1
9	2-001338	Nipple, 1" x 4", 316L SS	1
10	2-99075	Filter, Inlet	1
11	90-4001	Washer, 5/16" Flat, SAE	8
12	90-1007	Bolt, 5/16" x 1", NC HH	4
13	2-1059	Nipple, 3/4" Pipe x 1/2" Pipe	1
14	95-07400079	Bracket, Pump Support, Black	1
15	6-140158	Valve, Solenoid, Parker	1
16	6-0128	Conduitm Flex, Water Tight	6 ft.
17	2-11050	Swivel, 3/4" SAE Female, Push-On	2
18	90-2001	Nut, 5/16" ESNA, NC	4
19	90-2002	Nut, 3/8" ESNA	4

## HBG OPTIONS

### DEFOAMER ASSEMBLY EXPLODED VIEW

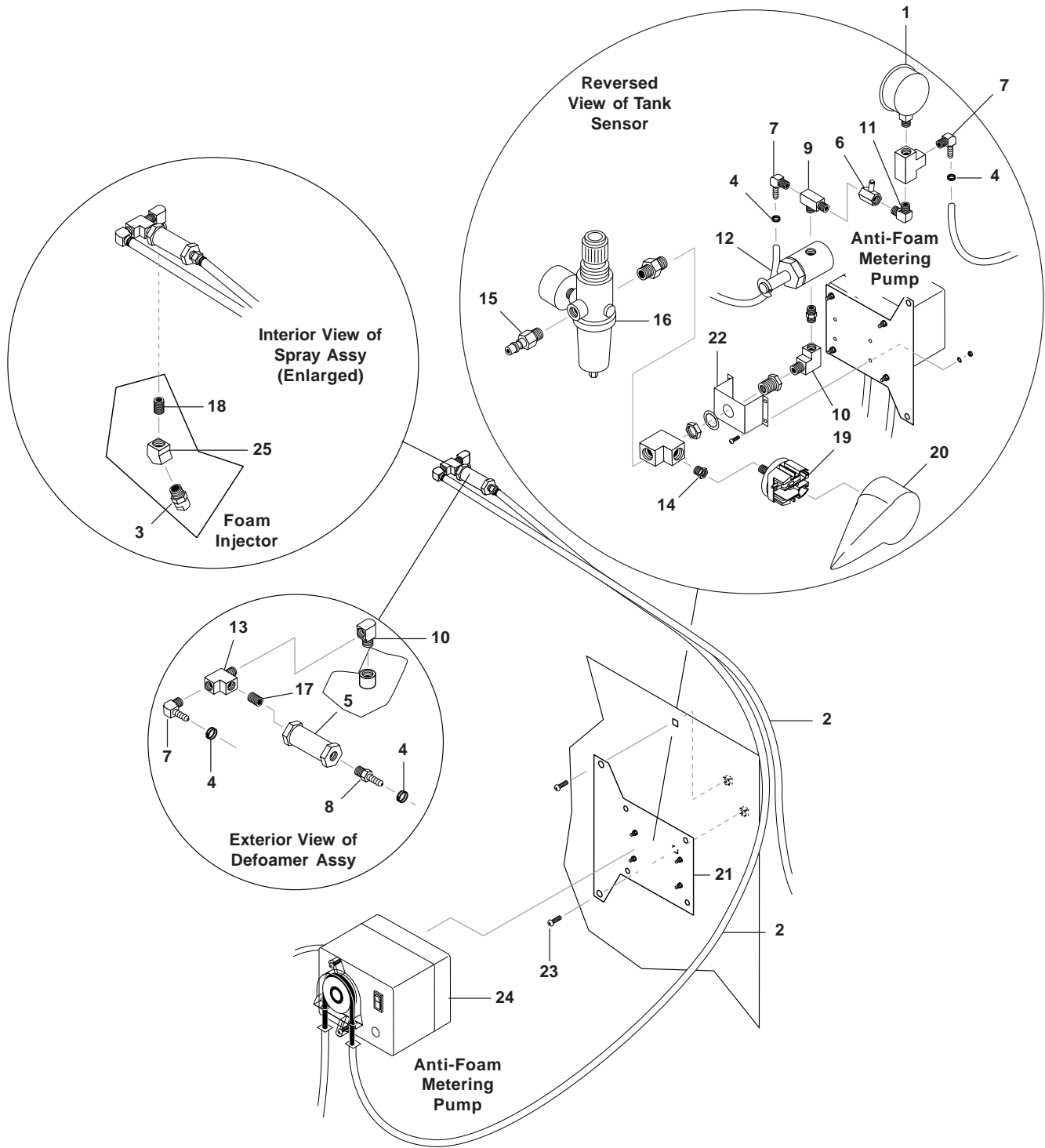

## HBG OPTIONS DEFOAMER ASSEMBLY PARTS LIST

ITEM	PART NO.	DESCRIPTION	QTY
1	4-05044	Gauge, Pressure, 0-10PSI	1
2	4-02100000	Hose, 1/4" Push-On	7 ft.
3	4-01420040S	Nozzle Only, 1/4" Meg	1
4	2-9040	Clamp, Hose, UNI .46 - .54	5
5	2-3070	Valve, 1/4" NPT, Check	1
6	2-3028	Valve, Inline Metering	1
7	2-1089	Hose Barb, 1/4" Barb x 1/4" Pipe, 90°	3
8	2-1085	Hose Barb, 1/4" Barb x 1/4" ML Pipe	1
9	2-1040	Tee, 1/4" Street	1
10	2-1022	Elbow, 1/4" Street	2
11	2-00260	Elbow, 1/4" Male, Pipe	1
12	6-140158	Valve, Solenoid, Parker	1
13	2-1037	Tee, 1/4" Branch, Male	2
14	2-1072	Bushing, 1/4" x 1/8" Pipe	1
15	2-2104	Nipple, 1/4" Mal Air	1
16	2-3017	Regulator, Air w/ Filter, 1/4" Ga	1
17	2-1002	Nipple, 1/4" Close	2
18	2-001338	Nipple, 1" x 4", 316L	1
19	6-050419	Pressure Switch, Barksdale	1
20	6-050432	Boot, Red, Tri Delta Switches	1
21	95-074134	Bracket, Defoamer Pump Mount	1
22	95-07163038	Support, Metering Valve	1
23	90-19995	Screw, 10/32" x 3/4" BH SOC	2
24	5-2360	Pump, VSP20 Metering, 120V	1
25	2-00265	Elbow, 1/4", 45°, 316L SS	1

**HBG OPTIONS**

**OIL SKIMMER ASSEMBLY 30-816 (30-8161SS) EXPLODED VIEW**

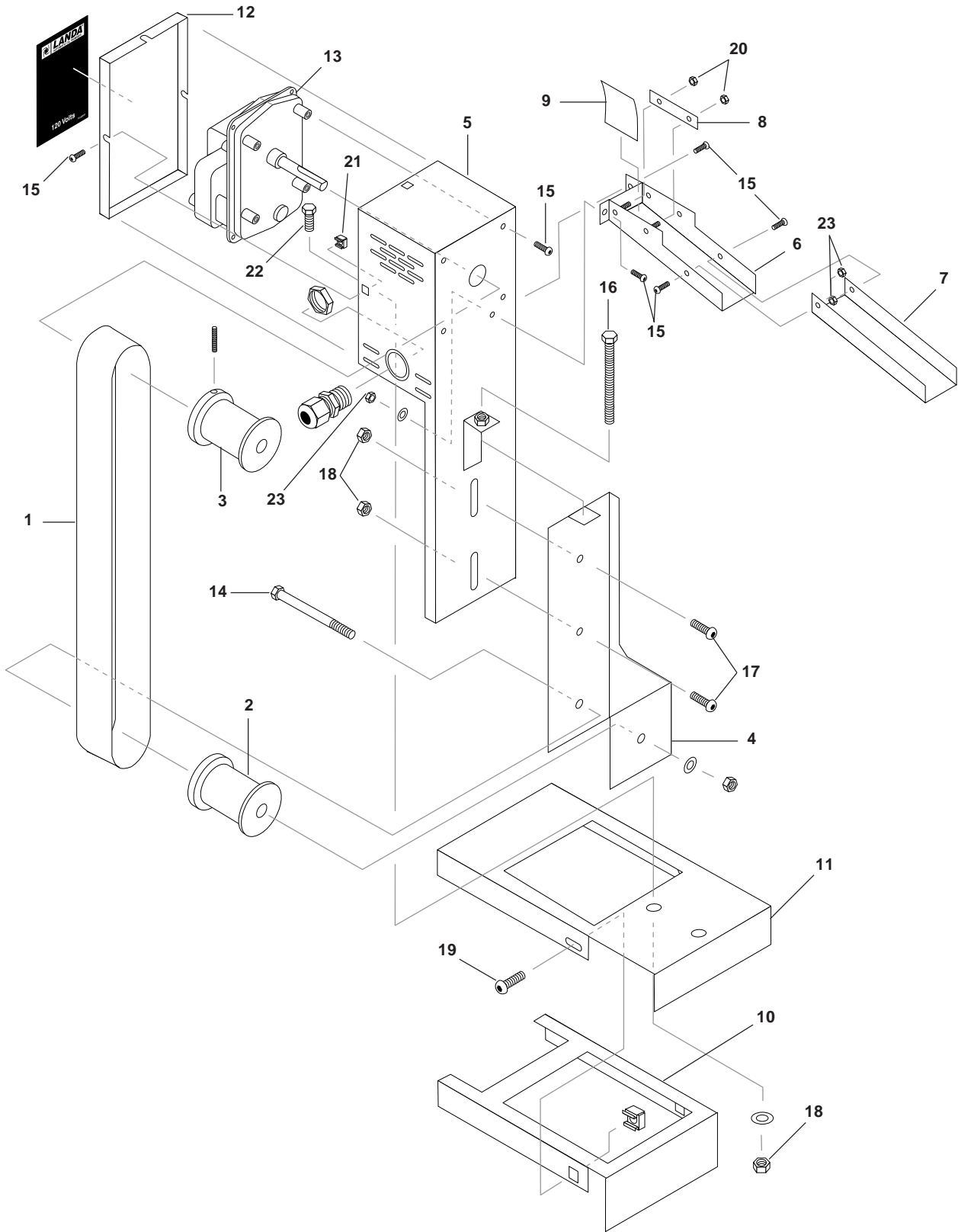

## HBG OPTIONS

### OIL SKIMMER PARTS LIST

ITEM	PART NO.	DESCRIPTION	QTY	ITEM	PART NO.	DESCRIPTION	QTY
1	95-074906	Belt	1	12	95-074905	Lid, Motor Cover, HRPO	1
2	95-074903	Spool, Lower	1	13	5-1094	Motor, Belt Skimmer	1
	95-0749031	Spool, Lower (316SS)	1	14	90-10122	Bolt, 5/16" x 3-1/2", NC	1
3	95-074904	Spool, Upper	1	15	90-1991	Screw, 10/32" x 1/2" BHSOC	13
	95-0749041	Spool, Upper (316SS)	1		90-19996	Screw, 10/32" x 1/2" BHSOC (316SS)	13
4	95-074916	Frame, Idler Pulley	1	16	90-18071	Screw, 1/4"-20 x 1-3/4", PHIL PH SS M/S	1
	95-0749161	Frame, Idler Pulley (316SS)	1	17	90-1995	Screw, 1/4" x 1/2" BH SOC CS	2
5	95-074915	Assy, Frame/Elec Box	1		90-1802	Screw, 1/4"-20 x 3/4" PHIL BH SS M/S (316SS)	4
	95-0749151	Assy, Frame/Elec Box (316SS)	1	18	90-20001	Nut, 1/4" ESNA, NC, SS	3
6	95-074917	Assy, Oil Ramp	1	19	90-1998	Screw, 1/4" x 3/4" BH SOC CS	1
	95-0749171	Assy, Oil Ramp (316SS)	1	20	90-200490	Nut, 8/32" KEPS	2
7	95-074911	Extension, Oil Ramp, 8, HRPO	1	21	90-2018	Nut, Cage, 10/32" x 16 Gauge	2
8	95-074912	Holder, Blade	1	22	90-1809	Screw, 1/4" x 3/8" SOC, Set, Blk	1
9	95-074908	Blade, Scraper	1	23	90-017	Nut, 10/32" Keps	7
10	95-074167	Bracket, Lower	1				
11	95-074165	Assy, Oil Skimmer Bracket	1				
	95-074168	Assy, Oil Skimmer Bracket (316SS)	1				

**Replacing Pump Head Tubing:**

**WARNING:** *Wear protective gloves, goggles, and other adequate protection for the chemical hazard. Before replacing the pump head, remove chemical from tubing as follows. Remove strainer from chemical tank then run pump until all chemical is removed from the tubing.*

1. Remove the hose clamps from the tubing at the pump head (twist clamp to disengage teeth).
2. Pull the suction and discharge tubing from the pump head tubing.
3. Rotate the pump head counterclockwise (See arrows in figure 3) to disengage from the latch studs on the feeder cover. Loosen the latch screws if necessary. **DO NOT REMOVE LATCH SCREWS.**
4. Grasp the tabs on the back cover of the pump head and pull straight out to remove.
5. Remove the old tubing and retaining collars from the pump head.
6. Position the spider as shown in figure 2. Then put the retaining collar on the pump head tubing as shown and position the collar in the pump head with the open end facing forward.
7. While rotating the spider counterclockwise, push the tubing into the housing to center over the rollers as shown in figure 2.
8. Replace the back cover on the pump head. **BE SURE BEARING IS IN BACK COVER (figure 2) PRIOR TO REPLACEMENT. BACK COVER MUST FIT FLUSH AND TIGHTLY AGAINST THE HOUSING (figure 3).**

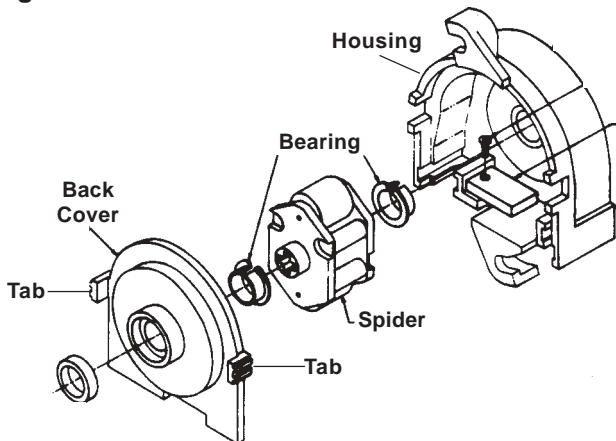
**Figure 1**

9. Slide the pump head onto the motor drive shaft and turn it clockwise to lock onto the 2 latch studs. **DO NOT REMOVE THE LATCH LOCK SCREWS.** Retighten latch screws to secure pump head.

10. Push the suction tubing and discharge tubing into the pump head tubing (Figure 3). **DO NOT PUSH TUBING PAST THE RETAINING COLLARS. INSTALL A HOSE CLAMP TO HOLD THE TUBING TOGETHER.** Use pliers to squeeze the clamp tightly.

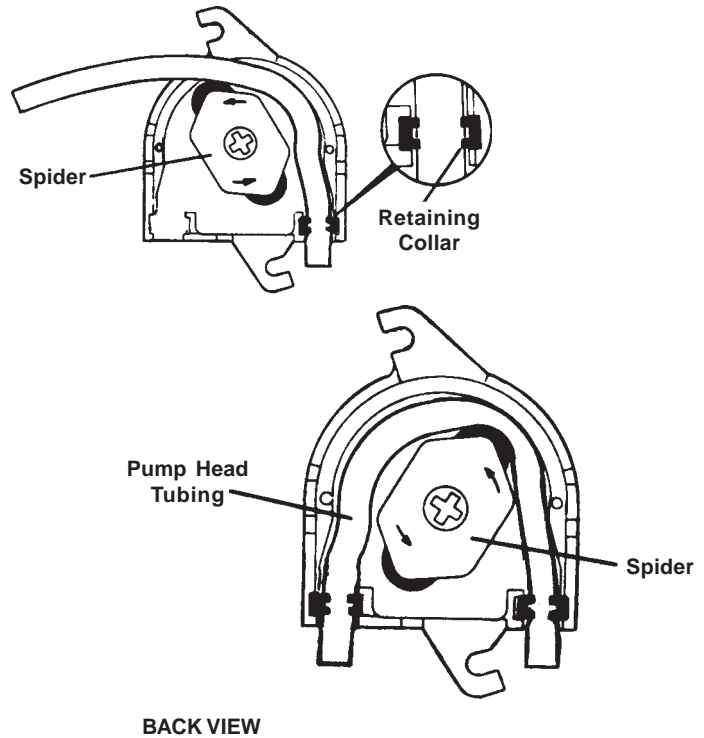
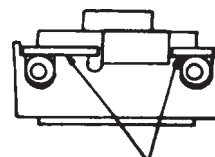
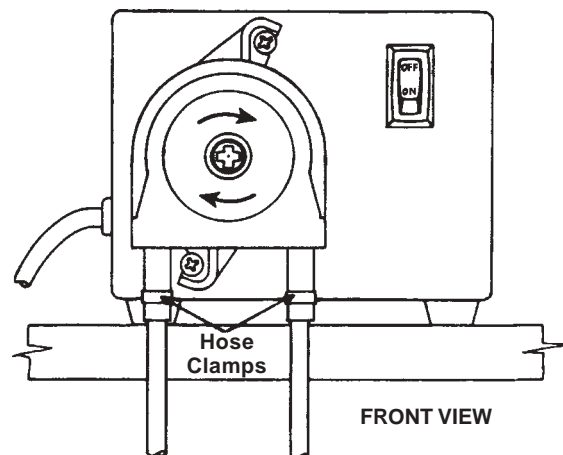
**Figure 2****Figure 3****BOTTOM VIEW**

Back cover must fit flush and tightly against pump housing

## VSP20 METERING ANTI-FOAM PUMP 120V • #5-2360

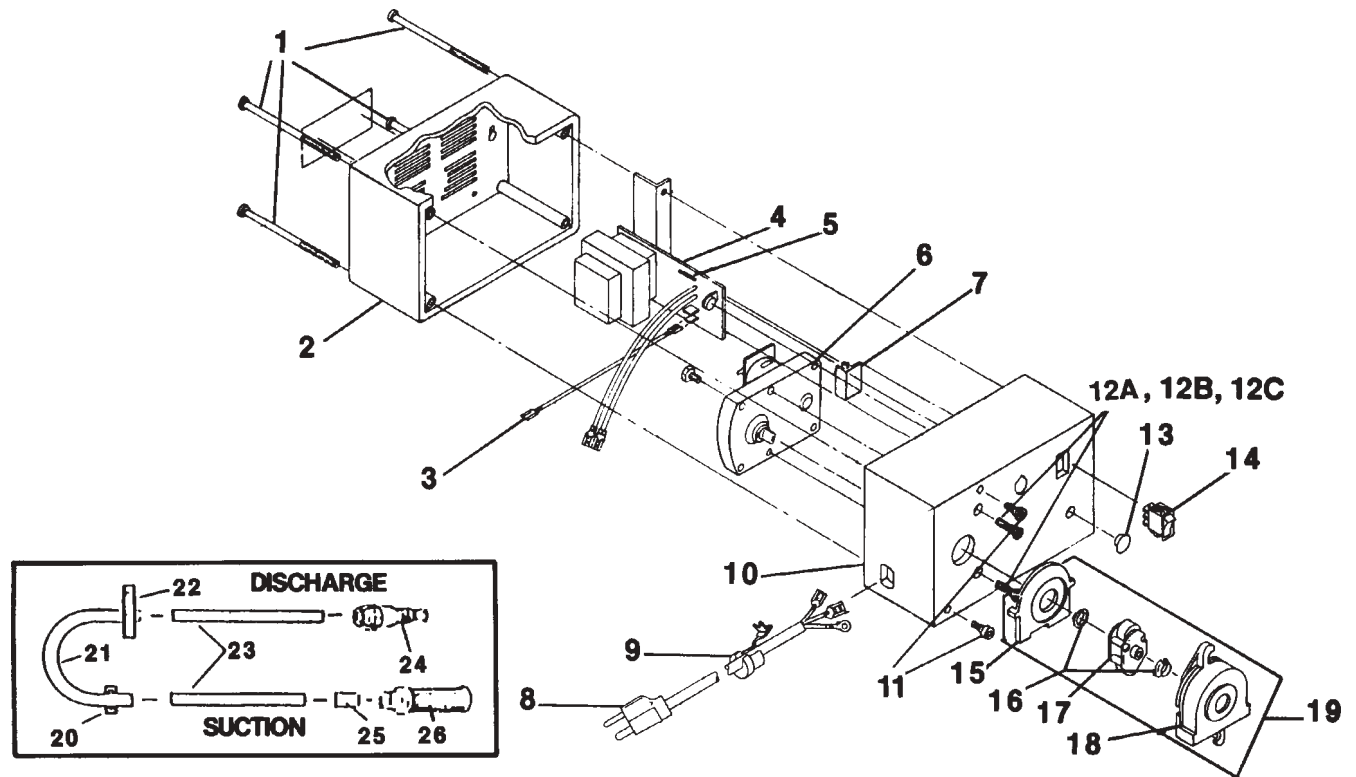
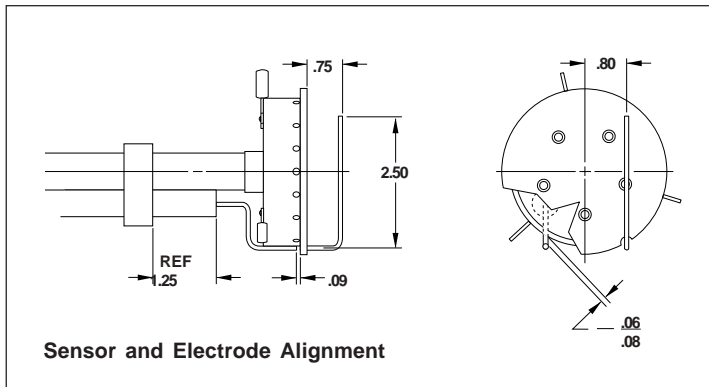
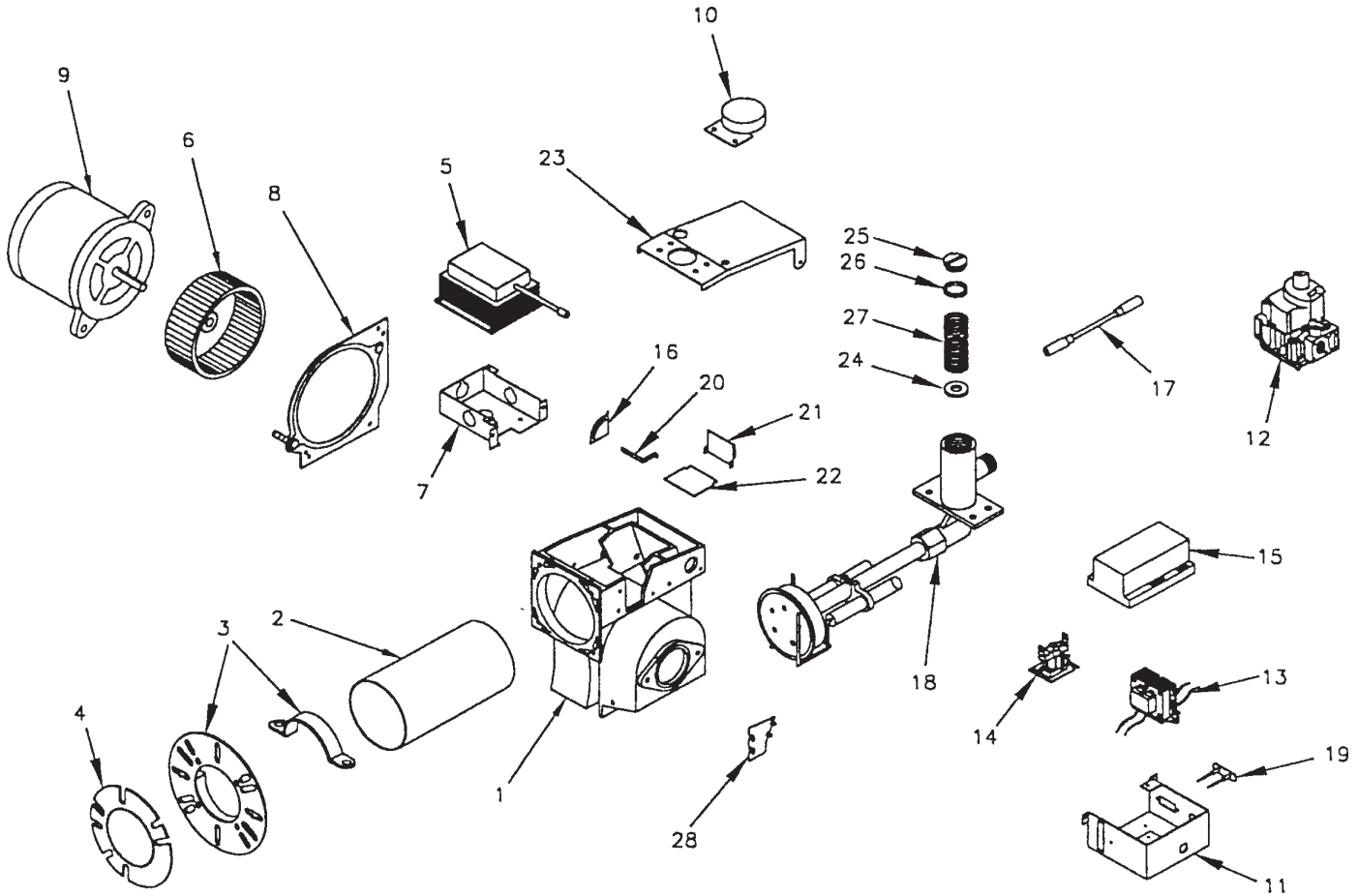

Figure 4

ITEM	PART NO.	DESCRIPTION	QTY	ITEM	PART NO.	DESCRIPTION	QTY
1	66-817995	Screw	4	15	66-817133	Pump Cover	1
2	66-818046	Rear Assembly	1	16	66-817121	Bearing	2
3	66-818071	Lead Assembly	1	17	66-817219	Spider Assembly	1
4	66-818306	PCB	1	18	66-817134	Pump Housing	1
5	66-818464	Fuse	1	19	66-8800651	Pump Head Kit	1
6	66-818667	Gearmotor Kit	1	20	66-817123	Collar, VSP-20	2
7	66-818315	Circuit Support	1	21	66-7013397	‡ Tube Kit, VSP-20	1
8	66-817998	Power Cord	1	22	66-817742	‡ Hose Clamps	2
9	66-L9900700-00	Strain Relief	1	23	66-8800431	‡ Tubing	1
10	66-818045	Front Housing	1	24	66-8800712	‡ I.P.F.	1
11	66-817888	Shoulder Screw	2	25	66-7012503	‡ Tube Sleeve	1
12A	66-818666	Motor Screw	2	26	66-816952	‡ Strainer	1
12B	66-32946	Motor Nut	1		66-8800721	▲ Lube Pad Kit	1
12C	66-811297	Lockwasher	2			▲ Not Shown	
13	66-818083	Hole Plug	1			‡ Available in Replacement Kit (#66-817976 - Figure 4)	
14	66-817923	Switch	1				



## Burner Assembly, HBG-30 MODEL #HSG-400 PART # 7-00046



## Burner Assembly

### PARTS LIST MODEL #HSG-400

ITEM	PART NO.	DESCRIPTION
1	7-100935-001	Burner Housing
2	7-63270-004	Air Tube , 6"
3	7-21724-011	Adjustable Flange Assembly
4	7-100428-002	Gasket
5	7-62407-001	Transformer
6	7-21642	Blower Wheel
7	7-21319	J-Box
8	7-21658	Side Plate
9	7-20627	Motor, 1/5-3450/115/60
10	7-63263-001	Pressure Switch
11	7-62408-001	Control Box
12	7-62374-004	Gas Valve
13	7-60186-004	Transformer
14	7-62406-002	Relay
15	7-62759-002	Primary Control

ITEM	PART NO.	DESCRIPTION
16	7-100377-002	Off Cycle Indicator
17	7-62909-001	Ignition Wire
18	7-62473-009	Gas Train Asm
19	7-60178	Terminal Strip
20	7-100372	Damper Arm
21	7-100378	Off Cycle Bracket
22	7-100371	Off Cycle Damper
23	7-62404-002	Housing Cover
24	7-8208	Orifice, 15/32" NG1
	7-8209	Orifice Q (.332) LP1
25	7-62385-001	Cap
26	7-62401-001	Gasket
27	7-62410-001	Spring
28	7-62399-002	Shield

## HSG Gas Train Assembly

ITEM	PART NO.	DESCRIPTION
1	7-62390-002	Probe
2	7-62391-002	Electrode
3	7-62575-001	Chamber/Manifold Asm

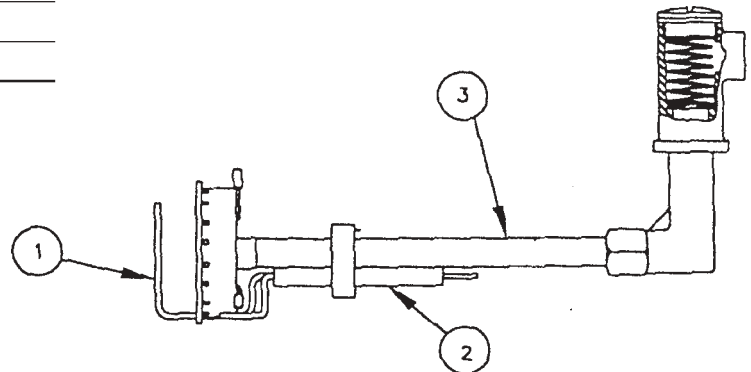

**TROUBLESHOOTING**

<b>PROBLEM</b>	<b>POSSIBLE CAUSE</b>	<b>SOLUTION</b>
<b>MACHINE WON'T POWER UP</b>	Breaker tripped	Reset breaker and reset batch cycle controller by pushing the F1/RST button.
	Batch cycle complete	Reset batch cycle controller by pushing the F1/RST button.
<b>PILOT DOES NOT LIGHT (HBG-15)</b>	Air in gas line	Bleed gas line.
	High or low gas pressure	Adjust air regulator.
	Blocked pilot orifice	Replace or clean orifice.
<b>PILOT GOES OUT FREQUENTLY DURING STANDBY (HBG-15)</b>	Restriction in pilot gas line	Clean line.
	Low gas pressure	Adjust pressure regulator.
	Blocked pilot orifice	Replace or clean orifice.
<b>PILOT GOES OUT WHEN GAS VALVE OPENS (HBG-15)</b>	Restriction in pilot gas line	Clean pilot orifice.
	High or low gas pressure	Test and adjust pressure.
	Excessive pressure drop when main gas valve opens	Increase size of inlet gas piping.
<b>BURNER MOTOR DOES NOT RUN</b>	Burned out fuse or current is off	Check fuse and replace.
	Thermostat or limit defective or improperly set	Test and reset thermostat.
	Relay or transformer defective	Test and replace.
	Motor burned out	Replace.
	Improper wiring	Check all connections.
	Manual reset high temperature switch is tripped	Scrape and clean floor of tank. Reset switch on back of control box.
	Liquid level is too high. High float is in up position	Remove enough water from tank to lower level float then restart burner.
<b>BURNER MOTOR RUNNING BUT NO FLAME</b>	Pilot out (HBG-15)	Restart burner.
	Very low or no gas pressure	Adjust pressure regulator.
	Motor running too slow	Check voltage.
<b>SHORT NOISY BURNER FLAME</b>	Pressure regulator set too low	Increase pressure.
	Air shutter open too wide	Close shutter.
	Too much pressure drop in gas line	Increase gas pipe size.
	Defective regulator	Replace.
<b>LONG YELLOW FLAME</b>	Air shutter not open enough	Open air shutter (see Air Setting page 10).
	Air openings or blower wheel clogged	Clean.
	Too much input gas	Turn gas pressure down.
<b>MAIN GAS VALVE DOES NOT CLOSE WHEN BLOWER STOPS</b>	Defective valve	Replace gas valve.
	Obstruction on valve seat	Replace gas valve.
<b>REGULATOR VENT LEAKING GAS</b>	Hole in diaphragm	Replace regulator.

## TROUBLESHOOTING

PROBLEM	POSSIBLE CAUSE	SOLUTION
<b>BURNER WON'T SHUT DOWN AT LOW WATER</b>	Low water float does not work	Check switch for continuity, then adjust or replace.
<b>WATER WON'T HEAT UP OR HEATS UP TOO SLOWLY</b>	Sludge buildup on floor or tank	Scrape sludge from bottom of tank.
	Incorrect gas supply for burner	Recheck manifold. Reset if needed.
<b>AIR PUMP WON'T START</b>	Long float, top micro switch not energized. Water too high	Keep evaporating or manually lower the water level.
	Air regulator setting adjusted too low	Readjust air regulator to between 50 and 100 psi.
	Air pump solenoid plugged	Clean out.
	No voltage to air pump solenoid coil	Check wiring in electrical box. Replace parts as needed.
	Bad air pump solenoid coil	Replace solenoid coil.
<b>WASTEWATER DISCHARGING FROM AIR PUMP EXHAUST</b>	Check for diaphragm rupture	If ruptured, replace.
	Check for diaphragm nut	Tighten nut.
<b>AIR BUBBLES IN DISCHARGE HOSE</b>	Check connections of suction plumbing	If loose, retighten.
	Check band clamps on intake manifold	If loose, retighten.
	Check o-rings between intake manifold and fluid caps	Replace o-rings if worn.
	Check tightness of diaphragm nut	Tighten nut.
<b>AIR PUMP BLOWS AIR OUT MAIN EXHAUST WHEN STALLED ON EITHER STROKE</b>	Check U cups on spool in major valve	Replace if needed.
	Check valve plate and insert for wear	Replace if needed.
	Check sleeve and o-ring on diaphragm connecting rod	Replace if needed.
	Check o-rings on piston for wear	Replace if needed.
<b>LOW DISCHARGE G.P.M.</b>	Check air supply	Adjust to between 50 and 100 psi.
	Check for plugged discharge hose	Unplug discharge hose.
	For the pump to prime itself it must be mounted in a vertical position so that the balls will check by gravity	Level machine.
	Check for pump cavitation - suction pipe should be 1/2" minimum or larger if high viscosity fluids are being pumped. Suction hose must be non-collapsible type, capable of pulling a high vacuum	Replace hoses if undersized.
	Check all joints on intake manifolds and suction connections. These must be air tight	Tighten all joints and connections.
	Check for sticking or improperly seating check valves	Clean check valves.
	If pump cycles at a high rate or runs erratically, check piston o-rings for wear	Replace o-rings if needed.

### HBG COST FORMULAS

Propane conversion from gallons of propane to therms for use in chart below: 1 Therm = 1.0929 gallons of propane. Multiply the cost of 1 gallon of propane by 1.0929 to determine the propane cost per therm. Example: Propane = \$1.50 gallon. Multiply 1.0929 (gallons of propane per therm) x \$1.50 (cost of gallon of propane) = \$1.6393 per therm.

MODEL	FUEL USAGE	EVAPORATION RATE
HBG-15	200,000 BTU / HR	15 gallons per hour
HBG-30	375,000 BTU / HR	28 gallons per hour

**Constants:**

- 1 cubic foot of natural gas = 1,000 BTU's
- 1 gallon of propane = 91,500 BTU's
- 1 gallon of propane = 0.915 therms
- 1 therm = 100 standard cubic feet of natural gas
- 1 therm = 100,000 BTU's

**Operating Cost for Natural Gas:**

$$\text{Gas Cost (Cost per Gallon)} = \frac{\text{HBG Rating BTU's per Hour} \times \text{Local Cost of Fuel per Therm}}{\text{BTU's per Therm} \times \text{HBG Evaporation Rate}}$$

**Operating Cost for Electricity:**

$$\text{Electricity Cost (Cost per Gal)} = \frac{\text{Volts} \times \text{Amps} \times \text{Cost of Kilowatt Hour}}{1000 \times \text{HBG Evaporation Rate}}$$

**Example for HBG-15:** 200,000 BTU/Hr, 40¢/Therm, 120 Volts, 3 Amps, 6¢/KWH

$$\text{Gas Cost } (\text{¢/Gal}) = \frac{200,000 \times .40}{100,000 \times 15} = 5.3 \text{ ¢/Gal} \qquad \text{Electricity Cost } (\text{¢/Gal}) = \frac{120 \times 3 \times .06}{1000 \times 15} = .1 \text{ ¢/Gal}$$

**Total Cost = 5.3¢ (gas) + .1¢ (elec) = 5.4¢/Gal**

### SPECIFICATIONS

MODEL	HBG-15	HBG-30
EVAPORATION RATE	10-15 GPH (38 - 57 Liter/Hr)	25-30 GPH (95 - 114 Liter/Hr)
ENERGY SOURCE	Natural Gas or LPG	
ENERGY USAGE	200,000 BTU/HR	375,000 BTU/HR
TANK CAPACITY	70 Gallons (265 Liters)	120 Gallons (379 Liters)
TANK MATERIAL	<b>MILD STEEL</b> 3/8" Plate Floor, 3/16" Gauge Walls <b>STAINLESS STEEL</b> 1/4" Plate Floor, 12 Gauge Walls	
INSULATION	Air Insulated	
WEIGHT	1,215 Lbs. (552 Kg)	1,485 Lbs. (675 Kg)
DIMENSIONS W x L x H	33" x 78.5" x 65" (84 x 199 x 165 Cm)	90" x 44" x 70" (229 x 112 x 178 Cm)
POWER REQUIREMENTS	120V, 1 PH, 3 Amps (15 amps for electric autofill)	
WARRANTY	1 Year Parts	1 Year Parts

## PREVENTATIVE MAINTENANCE

This evaporator was produced with the best available materials and quality craftsmanship. However, you as the owner have certain responsibilities for the correct care of the equipment. Attention to regular preventative maintenance procedures will assist in preserving the performance of your equipment. Contact your Landa dealer for maintenance. Regular preventative maintenance will add many hours to the life of your machine. Perform maintenance more often under severe conditions.

MAINTENANCE SCHEDULE		
Sludge	Inspect	Daily
	Remove	After each complete batch
Liquid Level Switches	Inspect	Daily
	Clean	Weekly
Inspect and Clean Tank(s)		After each complete batch
Lubricate Draft Inducer Motor		Semi-annually
Clean Draft Inducer Fins		Monthly
Wastewater pH between 8-10		Daily
Clean Water Screen/Filter		Weekly



## **WATER BLAZE LIMITED NEW PRODUCT WARRANTY WATER TREATMENT SYSTEMS**

### **WHAT THIS WARRANTY COVERS**

All *WATER BLAZE* water treatment systems are warranted by *WATER BLAZE* to the original purchaser to be free from defects in materials and workmanship under normal use, for the periods specified below. This Limited Warranty, subject to the exclusions shown below, is calculated from the date of the original purchase, and applies to the original components only. Any parts replaced under this warranty will assume the remainder of the part's warranty period. A 60 day grace period will be given for installation.

### **ONE YEAR PARTS AND 30 DAY LABOR WARRANTY:**

All components excluding normal wear items as described below.

### **WARRANTY PROVIDED BY OTHER MANUFACTURERS:**

Motors, which are warranted by their respective manufacturers, are serviced through these manufacturers' local authorized service centers. *WATER BLAZE* cannot provide warranty on these items.

### **WHAT THIS WARRANTY DOES NOT COVER**

This warranty does not cover the following items:

1. Normal wear items, such as seals, filters, gaskets, O-rings, packings, pistons, brushes, filtering media, ozone bulbs, sensors, UV scanners, oil-skimmer belt, impedance sensor.
2. Damage or malfunctions resulting from accidents, abuse, modifications, alterations, incorrect installation, improper servicing, failure to follow manufacturer's maintenance instructions, or use of the equipment beyond its stated usage specifications as contained in the operator's manual.
3. Damage due to freezing, sludge build-up, chemical deterioration (oxidation, chloride or fluoride corrosion).
4. Damage to components from fluctuations in electrical or water supply.
5. Normal maintenance service, including adjustments.
6. Transportation to service center, field labor charges, or freight damage.

### **WHAT YOU MUST DO TO OBTAIN WARRANTY SERVICE**

While not required for warranty service, we request that you register your *WATER BLAZE* Product by returning the completed registration card. In order to obtain warranty service on items warranted by *WATER BLAZE*, you must return the product to your Authorized *WATER BLAZE* Dealer, freight prepaid, with proof of purchase, within the applicable warranty period. If the product is permanently installed, you must notify your Authorized *WATER BLAZE* Dealer of the defect. Your Authorized *WATER BLAZE* Dealer will file a claim with *WATER BLAZE*, who must subsequently verify the defect. In most cases, the part must be returned to *WATER BLAZE* freight prepaid with the claim. For warranty service on components warranted by other manufacturer's, your Authorized *WATER BLAZE* Dealer can help you obtain warranty service through these manufacturers' local authorized service centers.

### **LIMITATION OF LIABILITY**

*WATER BLAZE'S* liability for special, incidental, or consequential damages is expressly disclaimed. In no event shall *WATER BLAZE'S* liability exceed the purchase price of the product in question. *WATER BLAZE* makes every effort to ensure that all illustrations and specifications are correct, however, these do not imply a warranty that the product is merchantable or fit for a particular purpose, or that the product will actually conform to the illustrations and specifications. **THE WARRANTY CONTAINED HEREIN IS IN LIEU OF ALL OTHER WARRANTIES, EXPRESS OR IMPLIED, INCLUDING ANY IMPLIED WARRANTY OF FITNESS FOR THE PARTICULAR PURPOSE, INCLUDING QUALITY OF WATER TREATMENT.** *WATER BLAZE* does not authorize any other party, including authorized *WATER BLAZE* Dealers, to make any representation or promise on behalf of *WATER BLAZE*, or to modify the terms, conditions, or limitations in any way. It is the buyer's responsibility to ensure that the installation and use of *WATER BLAZE* products conforms to local codes. While *WATER BLAZE* attempts to assure that its products meet national codes, it cannot be responsible for how the customer chooses to use or install the product.







Form #96-6411 • Revised 10/03 • Printed in U.S.A.