



VNG VLP

OPERATOR'S MANUAL

■ VNG/VLP3-1100

■ VNG/VLP4-2000

■ VNG/VLP4-3000

■ VNG/VLP6-3000

■ VNG/VLP8-2500

■ VNG/VLP4-4000



LANDA, INC. ■ 4275 N.W. Pacific Rim Blvd. ■ Camas, WA 98607 ■ USA

For technical assistance or the Landa Dealer nearest you, call 800-LANDA-4-U (800-526-3248) or (360) 833-9100
or consult our web page at www.landa-inc.com

CONTENTS

Introduction	5
Important Safety Information	5
Installation	5-10
Location	5
Installation Guide	6
Gas Codes	7
Electrical	7
Gas Piping	7
Propane Gas	7
Natural Gas	8
Venting	8
Draft Diverter	8
Water Source	8
Water Connection	8
Inspecting & Testing Gas Piping	9
Gas Pressure	9
Warning and Check Lists	9-10
Operating Instructions	11
Preventative Maintenance	11
General Operating Techniques	11
Component Identification	112
Maintenance & Service	13
Heating Coil	13
Gas Valve Regulator Adjustment	13-14
Propane Gas	14
Burner Features	14-15
VNG Control Panel	16
VNG Control Panel Parts List	17
VNG-S Exploded View, Left Side	18
VNG-S Exploded View, Right Side	19
VNG-S Parts List	20-21
VNG-L Exploded View, Left Side	22
VNG-L Exploded View, Right Side	23
VNG-L Parts List	24-25

CONTENTS

VNG-L Burner Assembly	26
VNG-L Burner Assembly Parts List	27
VNG6-3000 Pump Assembly Exploded View and Parts List	28-29
VNG Electrical Box	30
VNG Electrical Box Parts List	31
VNG Remote Electrical Box	32
Troubleshooting	33-37
Basic Facts	38
Pressure Equivalents	38
Burner Specifications	39
Preventative Maintenance Schedule	40
Oil Change Record	40
Warranty	41

Model Number _____

Serial Number _____

Date of Purchase _____

The model and serial numbers will be found on a decal attached to the pressure washer. You should record both serial number and date of purchase and keep in a safe place for future reference.

INTRODUCTION

Thank you for purchasing a Landa Pressure Washer.

This manual covers the operation and maintenance of the VNG/VLP3-11021D, 3-11021D/R, 4-20021A, 4-20021A/R, 4-20021B, 4-20021B/R, 4-20021C, 4-20021C/R, 4-20021F, 4-20021F/R, 4-30021A, 4-30021A/R, 4-30021B, 4-30021B/R, 4-30021C, 4-30021C/R, 4-30021F, 4-30021F/R, 6-30021B, 6-30021B/R, 6-30021C, 6-30021C/R, 6-30021F, 6-30021F/R, 8-25021B, 8-25021B/R, 8-25021C, 8-25021C/R, 8-25021F, and 8-25021F/R washers. All information in this manual is based on the latest product information available at the time of printing.

Landa, Inc. reserves the right to make changes at any time without incurring any obligation.

The VNG/VLP Series was designed for maximum use of 8 hours per day, 5 days per week.

Owner/User Responsibility:

The owner and/or user must have an understanding of the manufacturer's operating instructions and warnings before using this Landa pressure washer. Warning information should be emphasized and understood. If the operator is not fluent in English, the manufacturer's instructions and warnings shall be read to and discussed with the operator in the operator's native language by the purchaser/owner, making sure that the operator comprehends its contents.

Owner and/or user must study and maintain for future reference the manufacturers' instructions.

This manual should be considered a permanent part of the machine and should remain with it if machine is resold.

When ordering parts, please specify model and serial number.

IMPORTANT SAFETY INSTRUCTIONS

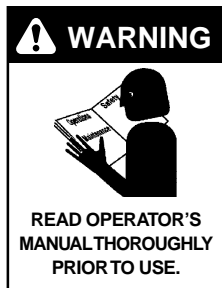

WARNING: When using this machine basic precautions should always be followed, including the following:

WARNING: To reduce the risk of injury, read operating instructions carefully before using.

1. Read the owner's manual thoroughly. Failure to follow instruc-

tions could cause malfunction of the machine and result in death, serious bodily injury and/or property damage.

2. Know how to stop the machine and bleed pressures quickly. Be thoroughly familiar with the controls.
3. Stay alert — watch what you are doing.
4. All installations must comply with local codes. Contact your electrician, plumber, utility company or the selling distributor for specific details.



WARNING: Flammable liquids can create fumes which can ignite causing property damage or severe injury.

5. Risk of explosion — do not spray flammable liquids or operate in an explosive location. Operate only where open flame or torch is permitted.



WARNING: Keep water spray away from electrical wiring or fatal electric shock may result. Read warning tag on electrical cord.

6. To protect the operator from electrical shock, the machine must be electrically grounded. It is the responsibility of the owner to connect this machine

to a UL grounded receptacle of proper voltage and amperage ratings. Do not spray water on or near electrical components. Do not touch machine with wet hands or while standing in water. Always disconnect power before servicing.

WARNING: Spray gun kicks back. Hold with both hands.

7. Grip cleaning wand securely with both hands before starting the cleaner. Failure to do this could result in injury from a whipping wand.



WARNING: Equipment can produce a high pressure stream of fluid that can pierce skin and its underlying tissues, leading to serious injury and possible amputation.

8. High pressure developed by these machines can cause personal injury or equipment damage. Use caution when operat-

ing. Do not direct discharge stream at people, or severe injury and/or death may result. This machine is to be used only by qualified operators.



CAUTION: Hot discharge fluid. Do not touch or direct discharge stream at persons.

- Never make adjustments on machine while in operation.



WARNING: High pressure can cause paint chips or other particles to become airborne and fly at high speeds.

- Eye safety devices and foot protection must be worn when using this equipment.



WARNING: Risk of asphyxiation. Use this product in a well ventilated area.

- When the machine is working, do not cover or place in a closed space where ventilation is insufficient.
- Machines with shut-off spray gun should not be operated with the trigger in the off position for extensive periods of time as this may cause damage to the pump.

- Protect from freezing.
- Be certain all quick coupler fittings are secured before using pressure washer.
- Do not allow acids, caustic, or abrasive fluids to pass through the pump.
- Inlet water must be from a cold, fresh city water supply.
- To reduce the risk of injury, close supervision is necessary when a machine is used near children. Do not allow children to operate the pressure washer. **This machine must be attended during operation.**
- The best insurance against an accident is precaution, and knowledge of the machine.
- Do not operate this product when fatigued or under the influence of alcohol or drugs. Keep operating area clear of all persons.
- Do not replace LP tank while machine is running. Serious injury could result.



WARNING: Use vapor fuel only.

- The VLP models are designed to run on vapor propane fuel. Do not use liquid fuel. Have a qualified serviceman install and service your equipment.
- Never expose a spark or flame where there may be unburned gas present.
- L.P. gases are heavier than air and will spill out on the floor. Therefore always provide adequate space and ventilation around these machines. Install the machine 18" above the floor.
- Landa will not be liable for any changes made to our standard machines, or any components not purchased from Landa.
- Do not overreach or stand on unstable support. Keep good footing and balance at all times.
- Follow maintenance instructions specified in manual.
- When making repairs disconnect from electrical source and shut off gas valve.
- Turn burner off and cool to 100°F before turning machine off.
- WARNING: If you smell gas, shut off the gas supply to the appliance.**
- Extinguish any open flame, and test all joints with a soap solution. If the odor persists, call your gas supplier immediately.
- This machine must be attended during operation.
- Not suitable for connection to Type B gas vent if the stack temperature exceeds 243° C (470° F).
- A draft hood shall be installed if this machine is going to be permanently installed and vented to the outside of the building.



INSTALLATION

Place machine in a convenient location providing ample support, drainage and room for maintenance.

Location:

This machine is certified for indoor installation. Its location should protect the machine from damaging environmental conditions, such as wind, rain and freezing.

- The machine should be run on a level surface where it is not readily influenced by outside sources such as strong winds, freezing temperatures, rain, etc. The machine should be located considering accessibility of the components and the refilling of detergents, adjustments and maintenance. Normal precautions

VNG INSTALLATION GUIDE
VNG3-1100, 4-2000, 4-3000, 4-4000

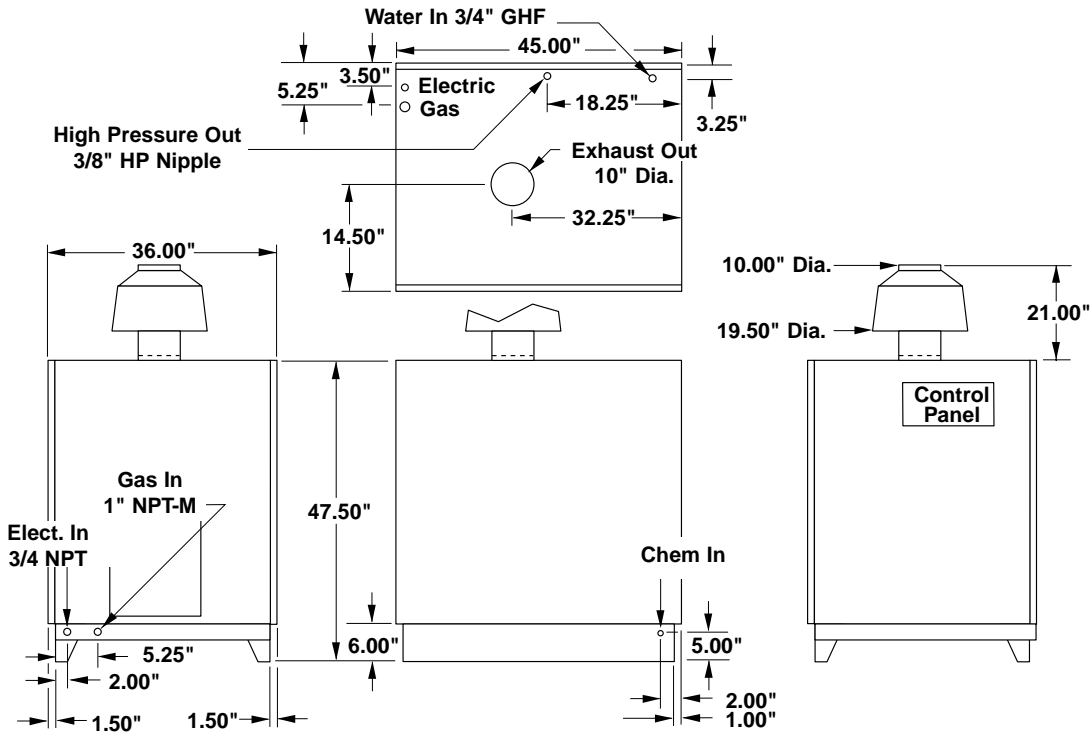

VNG6-3000, 8-2500

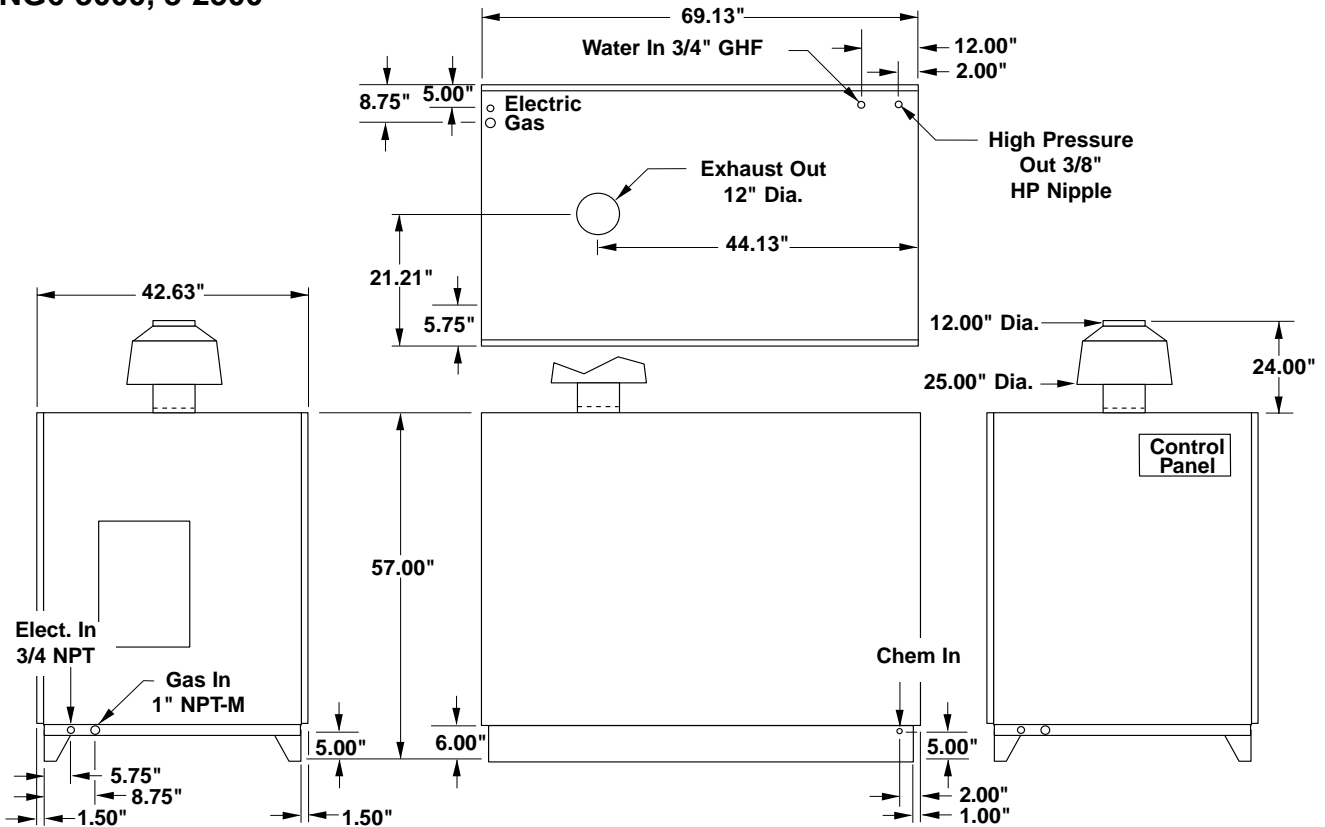

should be taken by operator of machine to prevent excess moisture from reaching power machine or electrical controls.

2. It is recommended that a partition be made between wash area and machine to prevent direct spray from spray gun from coming in contact with machine. Excess moisture reaching pressure washer or electrical controls will reduce life of machine and may cause electrical shorts.
3. During installation of machine, beware of poorly ventilated locations or areas where exhaust fans may cause an insufficient supply of oxygen. Sufficient combustion can only be obtained when a sufficient supply of oxygen is available for the amount of fuel being burned. If it is necessary to install a machine in a poorly ventilated area, outside fresh air may have to be piped to burner and a fan installed to bring air into area.
4. Do not locate near any combustible material. Keep all flammable material at least 20 feet away.
Allow enough space for servicing the machine.
Local code will require certain distances from floor and walls. (Two feet away should be adequate.)

AVOID SMALL LOCATIONS OR AREAS NEAR EXHAUST FANS.

Gas Codes:

Confer with local gas company and with proper municipal officials regarding any specific code or regulations governing the installation. The installation must conform to local codes.

Electrical:

The machine, when installed, must be electrically grounded in accordance with local codes. Check for proper power supply using a volt meter; check the serial plate for the correct requirements.

Gas Piping:

All piping must comply with local codes and ordinances of the National Fuel Gas Code. A sediment trap or drip leg must be installed in the supply line to the burner. See figure 1.

A union shall be installed in the gas line adjacent to and upstream from the control manifold and downstream from the manual main shut-off valve.

A 1/8" N.P.T. plugged tapping accessible for test gauge connection shall be installed immediately upstream of the gas supply connection for the purpose of determining the gas supply pressure to the burner, and to prevent damage to gas valve.

If a manual gas shut off valve is not in the gas supply line within six feet of the machine and in an accessible location, one shall be installed.

Figure 1

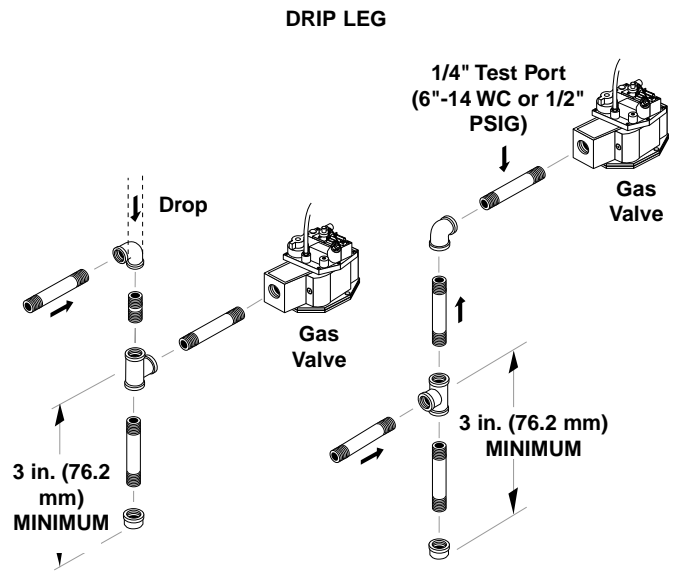

Sediment trap (drip leg) must be installed in the supply line.

Figure 2

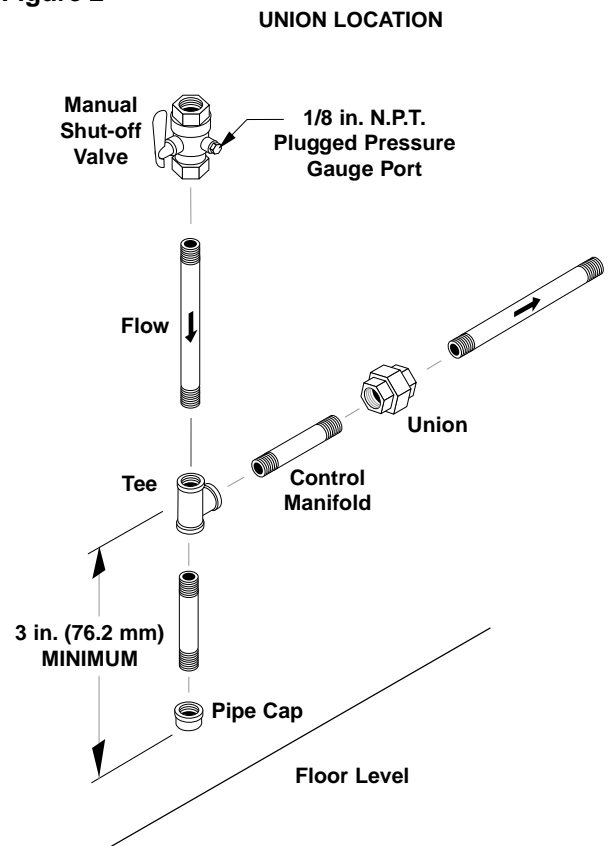

Location of union and drip leg for connecting conversion burner to house piping.

A manual shut-off valve shall be installed in the gas supply line external to the appliance. See Figure 2. The gas line should be a separate supply direct from the meter to the burner. It is recommended that new pipe be used and located so that a minimum amount of work will be required in future servicing. The piping should be installed to be durable, substantial and gas tight. It should be clear and free from cutting burrs and defects in structure of threading. Cast iron fittings or aluminum tubing should not be used for the main gas circuit. Joint compounds (pipe dope) should be used sparingly on male threads only and be approved for all gases.

Propane Gas:

The following pipe sizes should be used between the regulator and the gas valve on the burner.

Distance From Regulator	Pipe Size
0 - 50'	1" 1 PS
50' - 100'	1-1/2" 1 PS
100' - 200'	1-3/4" 1 PS

Natural Gas:

The following pipe sizes should be used between the meter and the cleaner.

Distance From Regulator	Pipe Size
0 - 50'	1-1/2" 1 PS
50' - 100'	2" 1 PS
100' - 200'	2-1/2" 1 PS

Venting:

Because this machine is installed indoors, regulations or ventilation concerns may call for a chimney or furnace pipe.

When venting the machine, if the machine is to be in an enclosed area with a stack on it, be sure the flue pipe is the same size as the stack on the machine. Poor draft will cause the machine to soot and not operate efficiently. When placing the machine for installation, keep in mind that the machine should be positioned in such a manner that the stack will be as straight as possible and protrude through the roof of the building at a proper location and at sufficient height to eliminate down draft. The flue pipe of a gas fired machine should be installed with a down draft diverter.

Input - BTU Per Hour	Draft Hood & Flue Pipe Size
410,000 - 600,000	10 inch
600,000 - 750,000	12 inch

Draft Diverter:

The draft diverter (figure 4) should be installed at least one (1) foot above the heating coil. The diverter serves to sever the chimney effect created in all sections of flue pipe positioned below to enhance the draft through the burner. It also helps prevent freezing of the coil due to wind chill factors.

Figure 4

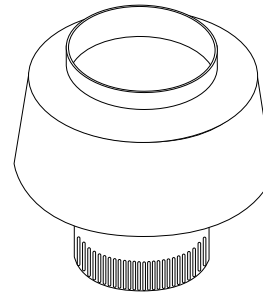

Standard On All Machines

When the pressure washer is installed in a tightly closed room without ventilation openings to the outdoors or other rooms, provisions shall be made for supplying air for combustion through special openings, one near the floor line and the other near the ceiling, each to be sized on the basis of one square inch or more of free area for each 1,000 BTU input per hour. See Figure 5.

When a room is of unusually tight construction and has a ventilating fan, which may be used for exhausting air to outdoors - or has a vented fireplace - it is recommended that combustion air be supplied to the enclosed room through intakes extending to the outside of the building and terminating in downturned fittings, suitably arranged to prevent obstruction from snow or rain, and including a protecting screen not smaller than 1/4 inch mesh.

Figure 5

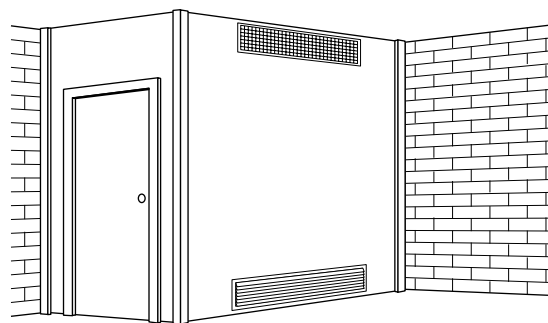

**Ventilating Air Opening
1 square inch for each
1000 BTU per hour input.**

Illustration showing air openings necessary to supply air for combustion when heating appliance is installed in an enclosed room.

Water Source:

Water source for machine should be supplied by a 5/8" I.D. garden hose with a city water pressure of not less than 30 psi. If the water supply is inadequate, or if the garden hose is kinked, the machine will run very rough and the burner will not fire.

Water Connection:

Connect the high pressure hose by pulling the coupler collar back and then inserting it onto the discharge nipple. Secure it by pushing the collar forward.

Attach the wand into the trigger spray gun using teflon tape on the pipe threads to avoid leaks.

Inspection and Testing Gas Piping:

The building structure should not be weakened by installing the gas piping. The piping should not be supported by other piping, but should be firmly supported with gas hooks, straps, bands or hangers. Butt or lap welded pipe should not be run through or in an air duct.

Before turning gas under pressure into piping, all openings from which gas can escape should be closed. Immediately after turning on gas, the system should be checked for leaks. This can be done by watching the 1/2 cubic foot test dial and allowing 5 minutes to show any movement, or by soaping each pipe connection and watching for bubbles. If a leak is found, make the necessary repairs and repeat the above test.

Defective pipes or fittings should be replaced and not repaired. Never use a flame or fire in any form to locate gas leaks, use a soap solution.

After the piping and meter have been checked completely, purge the system of air. **DO NOT** bleed the air inside an enclosed room.

The appliance and its individual shut-off valve must be disconnected from the gas supply piping system during the pressure testing of that system at test pressure in excess of 1/2 psig or damage to the gas valve will occur.

Gas Pressure:

The ideal incoming gas pressure is 11" wc (water column) (minimum 6" wc, maximum 14" wc or 1/2 psig). The correct operating manifold pressure for natural gas is 3.5" wc. The operating manifold pressure for propane gas is 11" wc. The gas valve pressure regulator can be adjusted between 3" and 4" wc natural gas or 6" and 11" wc for propane.

If the desired input rating cannot be obtained within the above manifold pressure adjusting range, the next size larger or smaller burner orifice should be used.

WARNING & CHECK LIST

WARNING

1. Installation or servicing of gas appliances and controls must only be performed by qualified personnel. After installation or servicing, test manual valve, operating valves, pressure regulation, and automatic shut-off valve for proper operation.
2. Install in a suitable dry location. The machine must be located in an area properly protected from the weather.
3. Shut off gas and electricity before starting installation or service. Turn gas back on to test or operate.
4. **DO NOT** connect pressure washer before pressure testing gas piping. Damage to gas valve may result (6" - 14" W.C.P. or 1/2 psig).
5. **DO NOT** insert any object other than suitable pipe or tubing in the inlet or outlet of the gas valve. Internal damage may occur and result in a hazardous condition.
6. **DO NOT** grip gas valve body with a pipe wrench or vise. Damage may result causing gas leakage. Use inlet or outlet bosses or a special body wrench.
7. **DO NOT** short the gas valve terminals.
8. **DO NOT** allow any flame to impinge on the regulator vent tubing if supplied. It may clog and cause gas valve malfunction.
9. **DO NOT** use the gas cock to adjust the gas flow.
10. In case main burner fails to shut off, turn off gas supply.
11. Keep all combustible materials away from gas appliances. **DO NOT** allow lint or dust to collect in burner area.
12. Dials must only be operated by hand. Never use pliers, wrenches or other tools to turn dials.
13. Leak test with a soap solution after installation or service with the main burner on. Coat pipe and tubing joints, gaskets, etc. Bubbles indicate leaks.
14. If the machine is installed in an enclosed room, care should be taken to ensure that an adequate supply of air is available for combustion and ventilation (1 sq. inch per 1000 BTU).

CHECK LIST BEFORE STARTING:

	YES	NO
Has gas supply been inspected by an authorized contractor to meet local codes?		
Is machine protected from downdraft and excessive wind?		
Is machine shielded from moisture or water spray?		
Is the voltage correct and are the circuit breaker and supply cord adequate according to specifications and serial plate notation?		
Is the machine electrically grounded?		
Is there ample water supply?		
Have all flammable liquids or gases been removed from installation location?		
Is there adequate gas supply for the BTU rating of the burner?		
Is incoming gas supply pressure to machine between 6"-14" water column inches or 1/2 psig?		
Has the proper gas regulator been installed for pressure and volume?		
Is the machine properly vented to allow adequate air flow?		
Are the propane tanks large enough, according to the rating of the machine, to prevent freezing?		
Have gas lines been checked for gas leaks?		
Have all operators using this machine been instructed properly and have they read the manual?		
Has the machine been installed according to operator's manual instructions?		

CAUTION: If "NO" has been checked on any of the above questions, do not operate the machine.

FOR YOUR SAFETY READ BEFORE LIGHTING
WARNING
If you do not follow these instructions exactly, a fire or explosion may result causing property damage, personal injury or loss of life.
A. This appliance has an electronic ignition system. When lighting the pilot, follow these instructions exactly.
B. BEFORE LIGHTING smell all around the appliance area for gas. Be sure to smell next to the floor because some gas is heavier than air and will settle on the floor.
FOR YOUR SAFETY
"WHAT TO DO IF YOU SMELL GAS"
<ul style="list-style-type: none"> • Do not try to light any appliance. • Do not touch any electrical switch, do not use any phone in your building. • Immediately call your gas supplier from a neighbor's phone. Follow the gas supplier's instructions. • If you cannot reach your gas supplier, call the fire department.
C. Use only your hand to turn the gas control. Never use tools. If the knob will not push in or turn by hand, don't try to repair it; call a qualified service technician. Forced or attempted repair may result in a fire or explosion.
D. Do not use this appliance if any part has been under water. Immediately call a qualified service technician to inspect the appliance and to replace any part of the control system and any gas control which has been under water.



CAUTION: This machine is equipped with an electronic ignition system. Lighting of the pilot is accomplished through electronic spark ignition. Do not attempt to light the appliance manually as a burn injury or electrical shock may result.

OPERATING INSTRUCTIONS

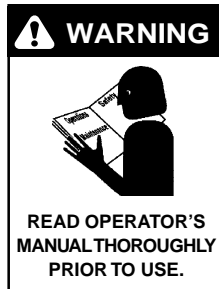

1. **STOP!** Read operator's manual before operating this machine. Failure to read operation and warning instructions may result in personal injury or property damage.
2. Turn all switches off.
3. Review installation instructions.
4. Connect water supply hose to the inlet connector and turn water on. Check for water leaks and tighten as needed.
5. Turn on the main gas supply and turn the gas valve control knob into the "ON" position (see page 12).
6. Close the steam knob and detergent valve by turning clockwise and setting the temperature control knob between 200° - 225°F.
7. Attach the desired high pressure nozzle into the wand quick coupler by pulling the coupler collar back and inserting the nozzle. Secure nozzle by pushing the coupler collar forward.
8. Turn the pump switch on and pull the trigger on the spray gun to activate the pressure switch which will then start the machine. When spray gun is closed more than 15 seconds, a time delay feature will turn the machine off. Trigger spray gun to start machine.
9. For hot water, push the burner switch to the ON position and pull the trigger on the spray gun. Sparking begins, the pilot gas ignites and then the ignitor/sensor will turn the main burner on. Optional remote control requires the pump switch to be turned ON before the burner and detergent switches will turn on.
10. To apply detergent, open the detergent valve counter clockwise making sure that the detergent pick up tube is in the detergent solution and not sucking air. On optional remotes the detergent switch needs to be turned to the OFF position then turned to the ON position to activate the detergent solenoid.
11. **To Stop:** Turn the burner switch off and place the detergent pick-up tube into fresh water. Open the detergent valve and trigger spray gun allowing detergent lines to be flushed and the burner to cool. Otherwise, coil damage will result.
12. When steam is needed, remove the side panel and turn the steam knob counterclockwise. Then turn the temperature adjustment knob to 275°F.
13. After water has cooled, turn pump switch to OFF position. If the machine is going to be off for an extended period of time, put the manual valve on the gas valve into the OFF position.
14. Turn the water off. Protect from freezing.

PREVENTATIVE MAINTENANCE

1. Check to see that water pump is properly lubricated.
2. Follow winterizing instructions to prevent freeze damage to the pump and coils.
3. Always neutralize and flush detergent from system after use.
4. If water is known to be high in mineral content, use a water softener in your water system or de-scale as needed.
5. Do not allow acidic, caustic or abrasive fluids to be pumped through the system.
6. Always use high grade quality Landa cleaning products.
7. Never run pump dry for extended periods of time.
8. Periodically delime coils as per instructions.

It is advisable, periodically, to visually inspect the burner. Check air inlet to make sure it is not clogged or blocked. Wipe off any oil spills and keep this equipment **clean and dry**.

The areas around the Landa washer should be kept clean and free of combustible materials, gasoline and other flammable vapors and liquids.

The flow of combustion and ventilating air to the burner must not be blocked or obstructed in any manner.

GENERAL OPERATING TECHNIQUES

If dirt comes off relatively easy and no grease and oil are present, cleaning with cold water will normally suffice. However, when grease and oil are present, hot water will greatly speed up the process.

Clean with the spray nozzle a foot or so from the surface being cleaned. For more difficult cleaning, move the nozzle in closer.

If the machine is equipped with a shut-off spray gun and various nozzle patterns, use the wide patterns for easy soil removal jobs and the narrow patterns on the more difficult jobs or for tight areas such as cracks and holes.

In most cases, faster results and better detergent economy will be obtained by applying the detergent and letting it "set" for a few minutes prior to rinsing. This enables the detergent to do its soil penetrating and loosening work.

Most cleaning work terminates with a high pressure rinse as part of the normal cleaning procedure. In some cases, however, the last operation may be application of a detergent or detergent (sanitizing, for example). After such work, run the machine for 20-30 seconds to clear pump and lines.

COMPONENT IDENTIFICATION
VNG-L W/O REMOTE

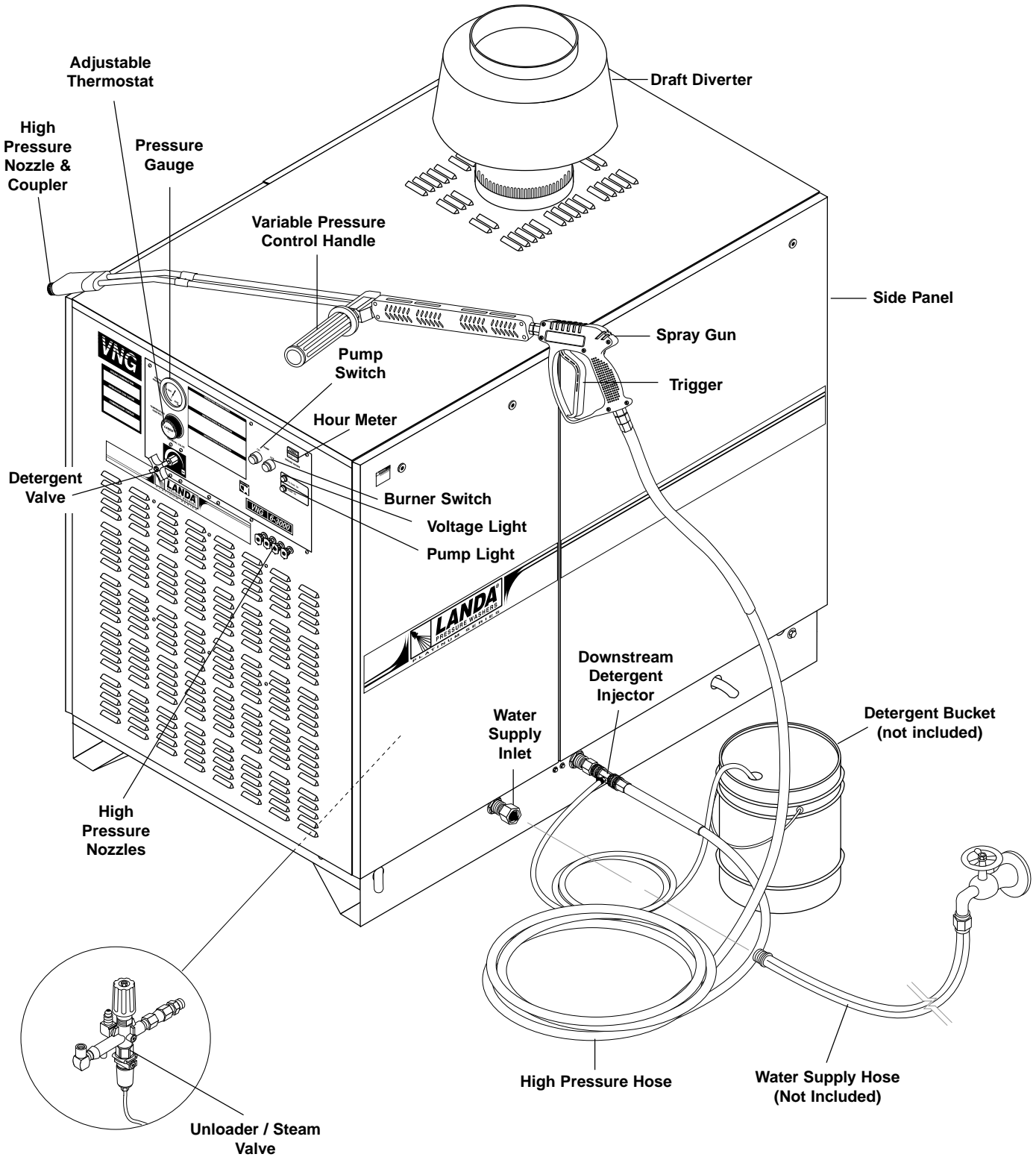

MAINTENANCE AND SERVICE

Spray Nozzles

Each machine is equipped with one or more spray nozzles, depending on model. Different spray nozzles are calibrated for each machine depending on the flow and pressure of that particular model. Spray nozzles vary in bore size and angle of spray. Popular spray angles are 0°, 15°, 25°, 40°. When ordering, please specify size and angle of nozzle. Nozzle size for each machine is located on the serial plate.

Unloader Valves:

Unloader valves relieve pressure in the line when the shut-off spray gun is closed. Unloader valves are preset and tested at the factory before shipping. Occasional adjustment of the unloader may be necessary to maintain correct pressure.

Winterizing Procedure:

Damage due to freezing is not covered by warranty. Adhere to the following cold weather procedures whenever the washer must be stored or operated outdoors under freezing conditions.

During winter months, when temperatures drop below 32°F, protecting your machine against freezing is necessary. Siphoning a small amount of antifreeze into the system is recommended. This is done by pouring a 50:50 mix of antifreeze and water into the float tank and then siphoning 100% antifreeze through the detergent line with the pump on. If compressed air is available, an air fitting can be screwed into the float tank strainer fitting and by injecting compressed air, all water will be blown out of the system. The use of a draft diverter will prevent the wind chill factor from freezing the coil.

Low Pressure Diagnosis

(Machines with shut-off spray gun)

Refer to the Troubleshooting Chart for low pressure. If, after referring to the chart, the trouble is found to be either the unloader or the pump, your next step is to determine which one is the problem. This can be done by eliminating the unloader from the system and attaching a 50' charge hose directly to the pump. If high pressure is developed in this manner the pump is good, and the unloader needs to be repaired or replaced. If low pressure is still present the pump needs repairing. **CAUTION:** When using this procedure to test components, keep the shut-off spray gun open at all times.

High Limit Hot Water Thermostat:

For safety, each machine is equipped with a high limit control switch. In the event the temperature of the water should exceed its operating temperature, the high limit control will turn the burner off until the water cools.

Pumps:

Use only SAE 30 weight non-detergent oil. Change oil after first 50 hours of use. Thereafter, change oil every three months or at 500 hour intervals. Oil level should be checked through use of the dipstick found on the top of the pump or by the red dot visible through the oil gauge window. Oil should be maintained at that level.

HEATING COIL

Condensation from Heating Coil

When cold water is being pumped into the water heater coil, and the burner is on, condensation will form on the coil and drip down into the burner compartment, giving the appearance of a leaking coil, particularly on cold humid days.

To Check Water Heater Coil for Leaks:

With the main burner "OFF" start machine and allow it to run a few minutes. Check into the burner compartment with a drop light or flashlight. If no leaks are visible, then water dripping from coil is from condensation.

Deliming Coil:

Periodic coil deliming is recommended.

1. Fill a container with 4 gallons of water, then add 1 lb. of deliming powder. Mix thoroughly.
2. Remove nozzle from spray gun assembly and put spray gun into container.
3. Attach a short section (3-5 ft.) of garden hose to machine to siphon solution from an elevated container or add mixture to the float tank. Turn pump switch on allowing solution to be pumped through coil and back into the container. Solution should be allowed to circulate 2-4 hours.
4. After circulating solution flush entire system with fresh water. Reinstall nozzle in spray gun.

GAS VALVE REGULATOR ADJUSTMENT

Adjustment of the built-in regulator isn't normally necessary, since it is preset at the factory. However, field adjustment may be accomplished as follows:

1. Attach manometer at pressure tap port.
2. Remove regulator adjustment screw cap.

3. With a small screwdriver, rotate the adjustment screw clockwise to increase or counterclockwise to decrease gas pressure.
4. Replace regulator adjustment screw cap (see Figure 6, next page).

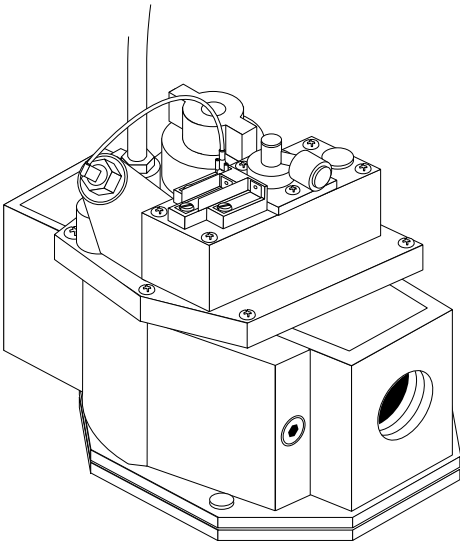
Figure 6

In alkaline water areas, lime deposits can accumulate rapidly inside the coil pipes. This growth is increased by the extreme heat build up in the coil. The best preventative for liming conditions is to use high quality cleaning detergents. In areas where alkaline water is an extreme problem, periodic use of Landa Deliming Powder will remove lime and other deposits before coil becomes plugged. (See Deliming Instructions for use of Landa Deliming Powder.)

Pressure Relief Valve

Each machine is equipped with a relief valve to relieve pressure in the system when higher than normally operating pressures are encountered. If operating pressure of machine is found to be normal and relief valve continues to leak, repair or replace the valve. **CAUTION:** Relief valve can become obstructed by deposits and must be unscrewed at least once per year to allow discharge.

PROPANE GAS

General Safety Precautions

Have a qualified gas service person assist in any gas burner installation or service. Few maintenance people or mechanics are knowledgeable in gas controls or related safety practices. Propane gas is heavier than air; unburned propane gas will gravitate to the floor rather than rise out of the stack. Hence, adequate floor space and good ventilation are especially important with propane systems.

Gas Pressure Requirements

All propane fired machines operate on vapor propane fuel only. They are designed to operate at a pressure of 11" w.c. (between 1/3 and 1/2 of one psi), and are often operated at even higher pressures when extra heat is needed.

Exterior regulators are needed to control the system. Propane bottles are not included with the machine. A high pressure regulator should be installed on the propane bottle and a low pressure regulator attached to the pressure washer.

Propane Cylinder Capacity

An important consideration with propane systems is the capacity of the supply cylinder relative to the needs of the burner. The burner operates on propane as a vapor gas. As gas is used from the propane cylinder, the liquid in the cylinder boils to maintain vapor gas pressure. This boiling process cools the liquid, and in a heavy, continuous-demand situation, the liquid temperature can fall to the point at which it cannot provide vapor gas as rapidly as is needed. In this case, it may be necessary to warm the propane cylinder by directing a warm spray, not over 120°F, on the cold cylinder or by manifolding two propane bottles together to increase total vaporization capacity. It is recommended that a minimum 100 lb. vapor propane bottle be used on the machine, depending on the length of running time desired.

BURNER FEATURES

Operated Automatic Valve

This machine is equipped with an Intermittent Pilot Ignition System. This system is designed to eliminate the need for a constant burning pilot. Lighting of the pilot is accomplished through electronic spark ignition each time the burner and flow switch call for heat. The pilot is not burning when there is no call for heat. Do not attempt to light the appliance manually as a burn injury or electrical shock may result. The pilot light will remain on and the main gas valve is turned off when the spray gun is closed.

Care of Main Burner

Due to condensation from heater coils dripping down on the burners, scale build-up may occur in the burner jet orifices.

1. TO REMOVE BURNER MANIFOLD FROM WATER HEATER COIL:

Turn off the gas to the main burner by turning the knob to the "OFF" position on the gas valve and the main gas supply.

Disconnect the pilot and ignition lines from the gas valve. Disconnect union in main burner line below thermostat. Slide burner manifold out through shell opening.

2. TO CLEAN BURNER JETS:

Select proper size drill for type gas involved. Use pin vise to hold drill and ream out each jet orifice.

CAUTION: Do not ream out orifices to a larger size.

If the water heater will be exposed to freezing weather, an anti-freeze solution should be circulated through the coil by whatever means are available for the particular system the water heater is used on.

To Adjust Pressure Regulator

Adjustment of the pressure regulator is not normally necessary since it is preset at the factory. However, field adjustment may be accomplished as follows:

1. Manometer attachment may be accomplished at the pressure tap plug.
2. Remove regulator adjustment screw cap (see Figure 6, page 14).
3. With small screwdriver, rotate adjustment screw "clockwise" to increase, or "counterclockwise" to decrease pressure.
4. Replace regulator adjustment screw cap.

VNG CONTROL PANEL
ALL MODELS

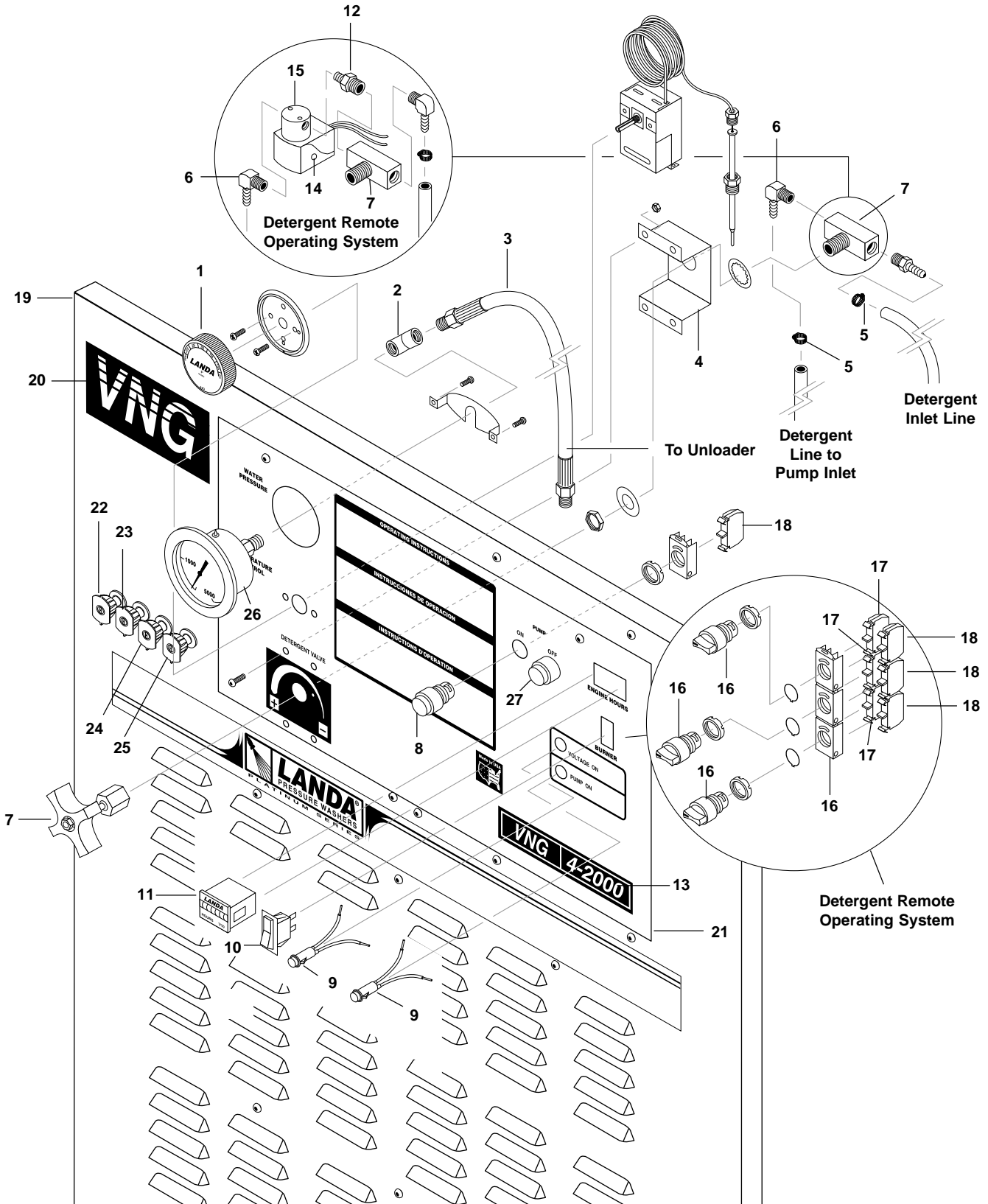

VNG CONTROL PANEL ALL MODELS PARTS LIST

ITEM	PART NO.	DESCRIPTION	QTY	ITEM	PART NO.	DESCRIPTION	QTY
1	4-05088	Thermostat, General, 302 Deg	1	18	6-2000	Block, Contact CH N/C (Remote)	3
2	2-0026	Elbow, 1/4" Female Pipe	1	19	95-07163058	Panel, Control, VNG Small	1
3	4-02021236	Hose, 1/4" x 36", 2 Wire Gauge Hose (S)	1		95-07163012	Panel, Control, VNG Large	1
	4-02021242	Hose, 1/4" x 42", 2 Wire Gauge Hose (L)	1	20	10-020VNG	Label VNG Lexan	1
4	95-07163038	Support, Metering Valve, VNG	1	21	10-99015	Label, VNG Control Panel	1
5	2-9000	Clamp, Screw #4	2		10-99031	Label, VNG Control Panel Remote	1
6	2-1089	Hose Barb, 1/4" Barb x 1/4" Pipe 90°	2	22	4-12805500	Nozzle, 0005.5 Red (3-1100)	1
7	2-3015	Valve, Control Metering	1		4-12804000	Nozzle, 0004 Red (4-3000)	1
8	6-2023	Switch, 2 Position CH, Auto Start Option	1		4-12806000	Nozzle, 0006 Red (4-2000, 6-3000)	1
	6-2021	Switch Green, Push Button	1		4-12810000	Nozzle 0010 Red (8-2500)	1
9	6-020530	Light, Indicator, Green, 125V	2	23	4-12805515	Nozzle 15055 Yellow (3-1100)	1
10	6-020251	Switch, Curvette (Burner)	1		4-12804015	Nozzle 1504 Yellow (4-3000)	1
11	4-050822	Hour Meter 115V	1		4-12806015	Nozzle 1506 Yellow (4-2000, 6-3000)	1
12	2-1003	Nipple, 1/4" Hex	1		4-12810015	Nozzle 1510 Yellow (8-2500)	1
13	10-2031100	Label 3-1100	1	24	4-12805525	Nozzle 2505.5 Green, (3-1100)	1
	10-2031500	Label 3-1500	1		4-12804025	Nozzle 2504 Green (4-3000)	1
	10-204200	Label 4-2000	1		4-12806025	Nozzle 2506 Green (4-2000, 6-3000)	1
	10-204300	Label 4-3000	1		4-12810025	Nozzle 2510 Green (8-2500)	1
	10-206300	Label 6-3000	1	25	4-12805540	Nozzle 4005.5 White (3-1100)	1
	10-2082500	Label 8-2500	1		4-12804040	Nozzle 4004 White (4-3000)	1
14	6-140160	Solenoid Coil, 120V (Remote)	1		4-12806040	Nozzle 4006 White (4-2000, 6-3000)	1
15	6-1401590	Valve, Chem Less Coil (Remote)	1		4-12810040	Nozzle 4010 White (8-2500)	1
16	6-2020	Switch, Selec CH (Remote)	3	26	4-05035	Guage 0-5000 PSI VNG	1
17	6-2001	Block, Contact CH N/O (Remote)	3	27	6-2022	Switch Red, Push Button	1

VNG-S EXPLODED VIEW, 3-1100 • 4-2000 • 4-3000 • 4-4000
LEFT SIDE

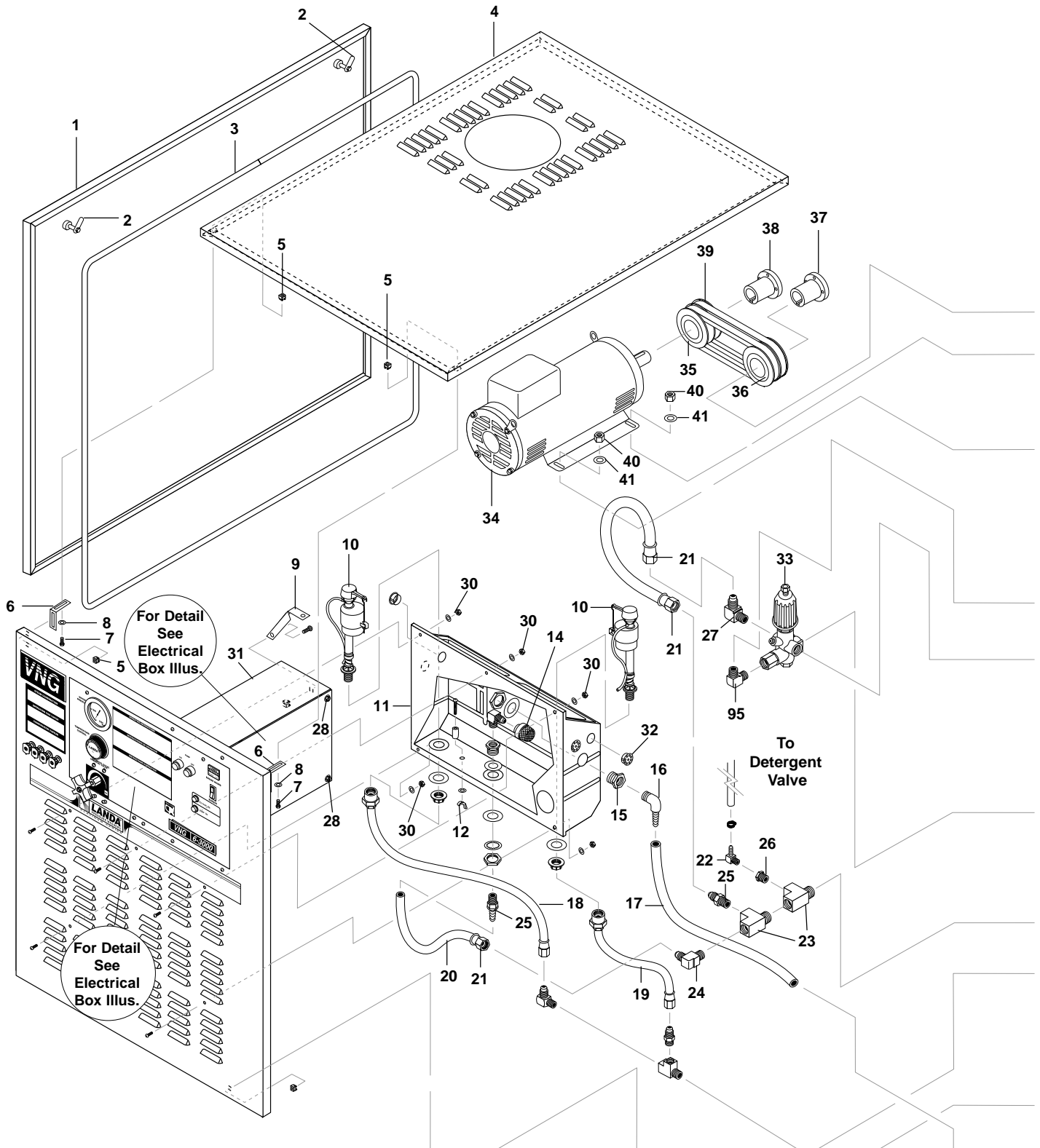

VNG-S EXPLODED VIEW, 3-1100 • 4-2000 • 4-3000 • 4-4000
RIGHT SIDE

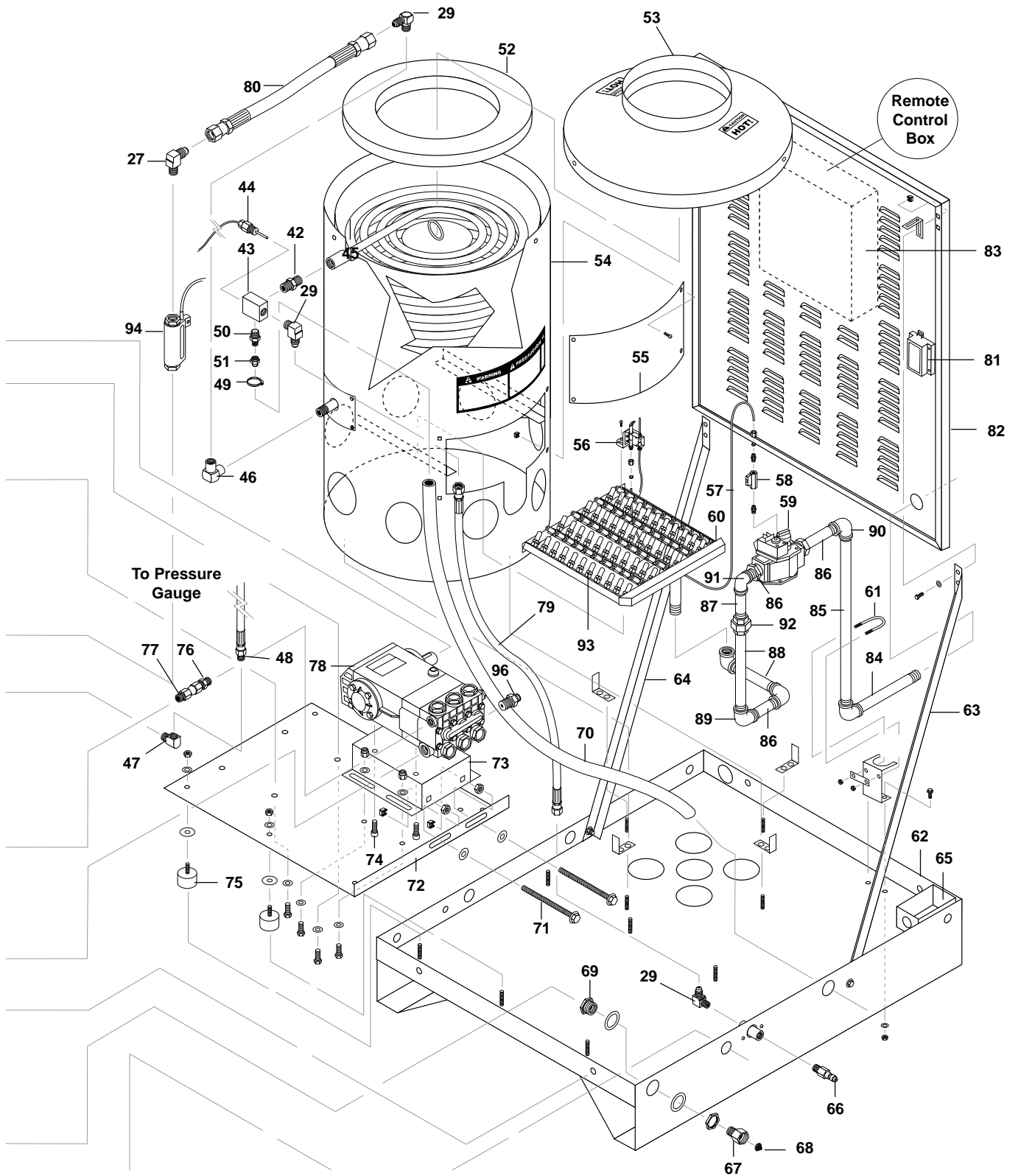

VNG-S EXPLODED VIEW, 3-1100 • 4-2000 • 4-3000 • 4-4000**PARTS LIST**

ITEM	PART NO.	DESCRIPTION	QTY	ITEM	PART NO.	DESCRIPTION	QTY
1	95-07163062	Panel, Side VNG-S	2	34	5-1047	Motor 2 HP, 1 PH, 3-11	1
2	90-50033	Latch, Vise Action	4		5-10401	Motor 6 HP 1 PH, 4-2A	1
3	2-011041	Trim w/Sponge /Ft.	42		5-1011	Motor 6 HP 3 PH, 4-2B, C	1
4	95-07163057	Panel, Top VNG-S	1		5-1027	Motor 5 HP 3 PH 575V, 4-2F	1
5	90-2022	Nut, Cage, 1/4" x 16 Ga.	4		5-1013	Motor 7.5 HP 1 PH, 4-3A	1
6	95-0763034	L-Bracket, VNG	4		5-10145	Motor 7.5 HP 3 PH, 4-3B, C	1
7	90-1001	Bolt, 1/4" x 3/4" NC HH	22		5-10146	Motor 7.5 HP 3 PH 575V, 4-3F	1
8	90-4000	Washer, 1/4" Flat SAE	22		5-10402	Motor 6 HP 1 PH, 1800 RPM 200V, 4-2G	1
9	95-07163032	Brace, VNG Elec Box	1		5-10111	Motor 6 HP 1 PH, 1800 RPM 200V, 4-2H	1
10	2-3014	Valve, Fluidmaster 400A	2		5-10144	Motor 7.5 HP 3 PH, 200V, 4-3H	1
11	2-01164	Tank, Plastic, Universal Float	1		5-10131	Motor 7.5 HP 1 PH, 200V, 4-3G	1
12	2-0151	Plug, Float Tank	1		5-1025	Motor 15 HP 3 PH, 4-4	1
13	2-1053	Nipple, 1/2" JIC x 1/2" Pipe	4	35	5-40102858	Pulley, Bore, AK28 x 5/8, 3-11	1
14	2-1906	Strainer, 1/2" Basket	1		5-40205401	Pulley, 2AK 54H, 4-2	1
15	2-010050	Bulkhead, 3" Ft x FT	1		5-40504501	Pulley, 2BK, 45H, 4-3	1
16	2-0100379	Adapter, 3/4" x 3/4" MT x Insert, 90 DGR	1		5-406050	Pulley, 2TB 50H, 4-4	1
17	4-02120000	Hose, 3/4" Push-on /Ft.	3	36	5-40108401	Pulley, AK 84H, 3-11	1
18	4-02100045	Inlet Hose, 45", Water Supply	1		5-40208401	Pulley, 2AK 84H, 4-2	1
19	4-02100030	Inlet Hose, 30", Water Supply	1		5-40508001	Pulley, 2BK 80H, 4-3	1
20	4-02110000	Hose, 1/2" Push-on /Ft.	3		5-40505001	Pulley, 2BK 50H, 4-4	1
21	2-1105	Swivel, 1/2" JIC Fem, Push-on	4	37	5-512024	Bushing, 24mm	1
22	2-1089	Hose Barb, 1/4" Barb x 1/4" Pipe 90 DGR	1	38	5-511113	Bushing, H x 1-1/8", 4-2	1
23	2-1041	Tee, 3/8" Street	3		5-511138	Bushing, H x 1-3/8", 4-3	1
24	2-1062	Elbow, 1/2" JIC x 1/2" Pipe 90 DGR	3	39	5-601035	Belt A-35, 3-11	1
25	2-1108	Push-ON, 3/8" Male Pipe	1		5-602037	Belt AX-37, 4-2	2
26	2-1076	Bushing, 1/2" x 1/4" Brass	1		5-604036	Belt, BX-36, 4-3	2
27	2-1060	Elbow, 1/2" JIC x 3/8" 90 DGR	2	40	90-2002	Nut, 3/8" ESNA	8
	2-0053	Elbow, 1/2" JIC x 3/8" 90 DGR	2	41	90-4002	Washer, 3/8" Flat, SAE	16
28	90-19942	Screw, 10/32" x 3/4" HEX	4	42	2-0008	Nipple, 1/2" Hex, Steel	1
29	2-0054	Elbow, 1/2" JIC x 1/2" 90 DGR	2	43	95-07101226	Block, Discharge, Brass 1/2" x 1/2"	1
30	90-017	Nut, 10/32" KEPS	3	44	4-05088	Thermostat, General 302 DGR	1
31	95-07163028	Box Elec. VNG	1	45	95-07121220	Coil, Dura 20" Dia, Sch 80	1
32	2-0147	Plug Overflow	2	46	2-0028	Elbow 1/2" 90 DGR Fem. Pipe	1
33	5-3208	Unloader AL 607, 7.8 GPM	1	47	2-1022	Elbow 1/4" Street	1
	5-3206	Unloader, Pulsar 280 w/Switch, Auto Start Option	1				

VNG-S EXPLODED VIEW, 3-1100 • 4-2000 • 4-3000 • 4-4000 PARTS LIST (CONTINUED)

ITEM	PART NO.	DESCRIPTION	QTY	ITEM	PART NO.	DESCRIPTION	QTY
48	4-02021236	Hose 1/4" x 36" Gauge Hose	1	79	4-02047736	Hose, 3/8" x 36", 2 Wire	1
49	2-90041	Clamp, Screw #16	1	80	4-02047725	Hose, 3/8" x 25", 2 Wire	1
50	2-3400	Adapter, Burst Seal	1	81	7-70151	Ignition, Electronic Control	1
51	2-3480	Rupture Disk Replacement, 8000 PSI	1	82	95-07163060	Panel, Burner End	1
	2-3480	Rupture Disk Replacement 3000 PSI	1	83	6-03901	Box, Metal, Junction, 12" x 12" x 4" Remote	1
52	7-01415	Insulation, Tank Head, 20"	1	84	2-00132	Nipple, 1" x 6" Black Pipe	1
53	95-07163099	Top, Burner Wrap 20"	1	85	95-07163077	Pipe, 1" NPT x 18" Black	1
54	95-07163094	Wrap, Outer Assy, 20"	1	86	2-00162	Nipple, 3/4" x 3" Black Pipe	3
55	95-07163097	Cover, Burner Access, 20" Coil	1	87	2-00165	Nipple, Black Pipe 3/4" x 5"	1
56	7-70237	Pilot, Natural Gas Pilot	1	88	2-00164	Nipple, 3/4" x 6" Black, Pipe	2
57	7-0150	Tubing, Aluminum /in.	36	89	2-00291	Elbow, 1" Black Pipe 90 DGR	1
58	2-3006	Valve, 1/4" Jomar, T-91LP, Ball	1	90	2-00295	Elbow, 1" x 3/4" Reducing 90 DGR	3
59	7-70002	Valve, Gas 7000 DERCH	1	91	2-00293	Elbow, 3/4" Black, 90 DGR	3
60	95-07163096	Burner Assy, Square, Small	1	92	2-0087	Union, 3/4" Black Pipe	1
61	90-10130	U-Bolt, 5/16" x 1" Pipe	3	93	7-7030	Jet Orifice NG #54	46
62	95-07163052	Base, VNG, Small	1		7-7022	Jet Orifice LP #69 (See chart page 39)	46
63	95-07163066	Brace, Right Side, VNG-S	1	94	6-02172	Switch Pressure N/O	1
64	95-07163064	Brace, Left Side VNG-S	1		6-021730	Switch Flow, MV-60	1
65	6-04110	Box, Junction 3 Hole, 3/4"	1	95	2-00270	Elbow, 3/8" Male	1
66	2-2017	Nipple, 1/2" Male Pipe	1	96	2-30082	Pump Protector, 1/2" PTP	1
67	2-10942	Swivel, 1/2" MP x 3/4" GHF	1				
68	2-1902	Strainer, Inlet, Garden Hose	1				
69	2-11041	Connector, 1/2", Anchor	1				
70	4-02130050	Hose, 7/8" Push-On /FT	2				
71	90-10225	Bolt, 3/8" x 3-1/2" Tap	2				
72	95-07121013	Platform, Motor, 3-11	1				
	95-071210136	Platform, Motor 3/16" 4-2, 4-3	1				
73	95-07121112	Rail, Pump, Gen. Combo	1				
74	90-1016	Bolt, 3/8" x 1" NC HH	8				
75	2-01011	Isolator, 5/16" Fem x fem	6				
76	2-0051	Nipple, 1/2" JIC x 3/8" Pipe	1				
77	2-0079	Swivel, 1/2" JIC FEM x 3/8" Pipe	1				
78	5-2302	Pump, General T-991, 3-11	1				
	5-2304	Pump, General T1011, 4-2	1				
	5-2307	Pump, General TS 2021, 4-3, 6-3	1				
	5-2320	Pump, General T-9281, 4-4	1				

VNG-L EXPLODED VIEW, 6-3000 • 8-2500
LEFT SIDE

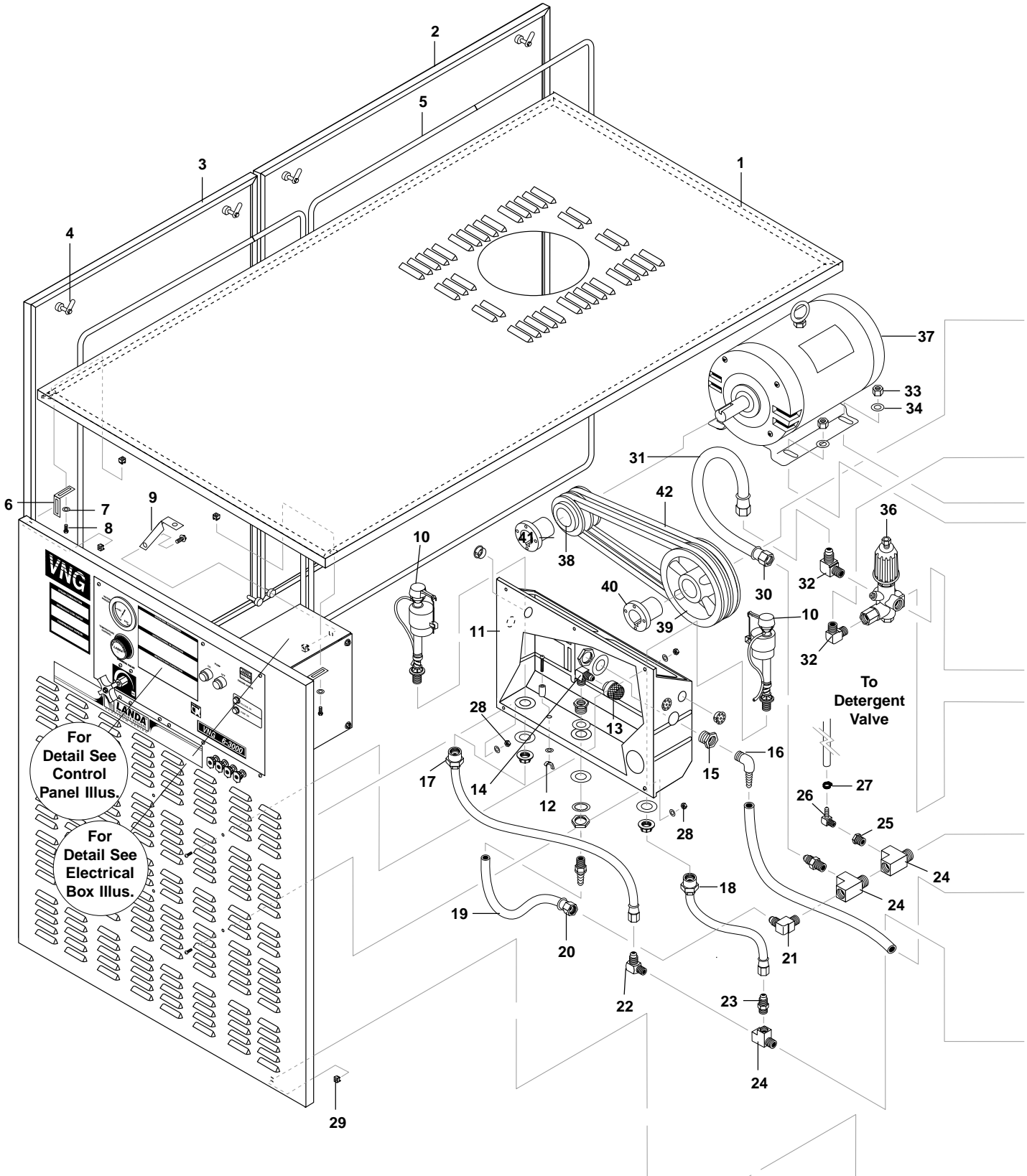

VNG-L EXPLODED VIEW, 6-3000 • 8-2500
RIGHT SIDE

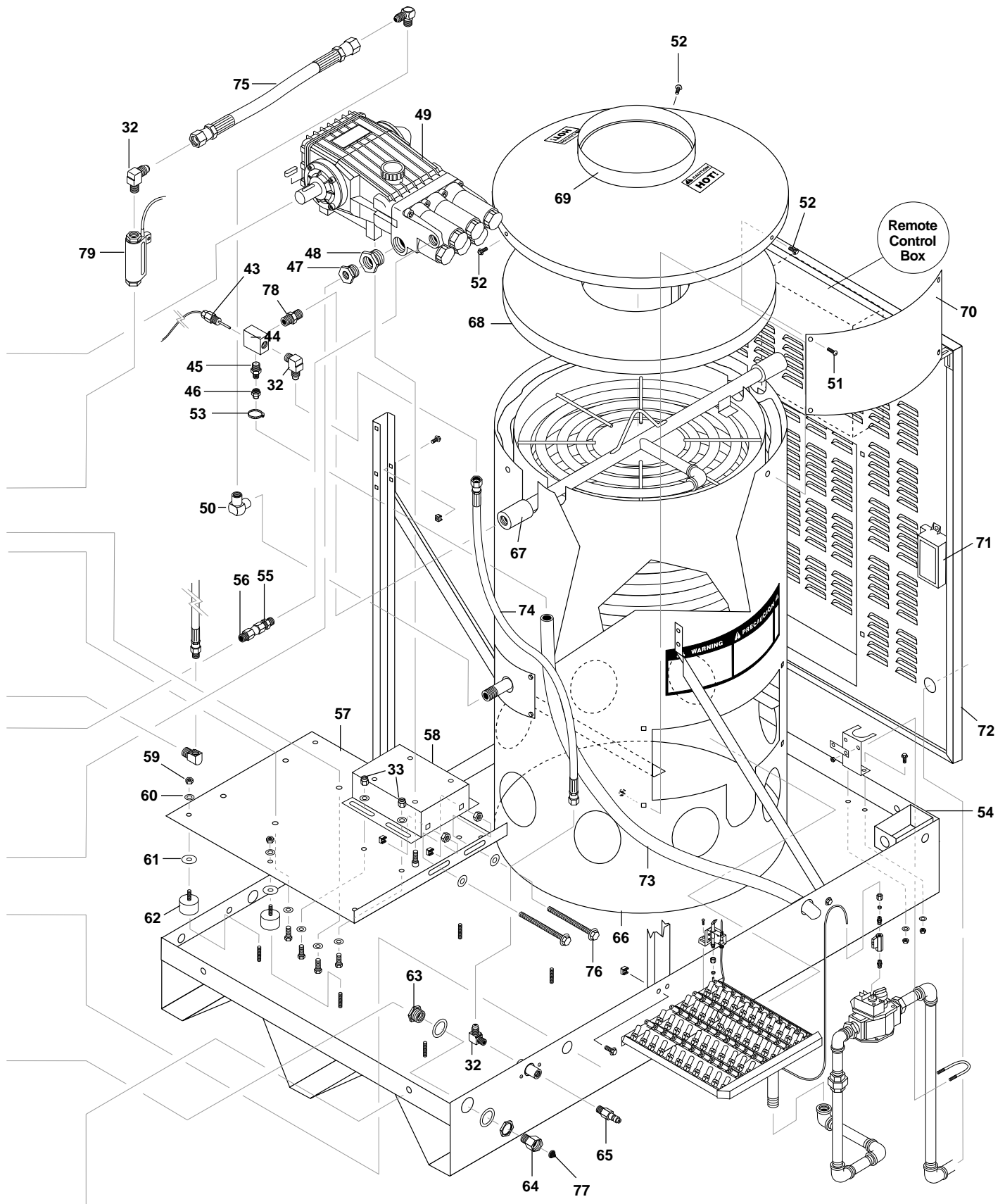

**VNG-L EXPLODED VIEW, 6-3000 • 8-2500
PARTS LIST**

ITEM	PART NO.	DESCRIPTION	QTY	ITEM	PART NO.	DESCRIPTION	QTY
1	95-07163010	Panel, Top VNG-L	1	33	90-2002	Nut 3/8" ESNA	8
2	95-07163018	Panel, Side VNG-L Large	2	34	90-4002	Washer Flat 3/8"	8
3	95-07163020	Panel, Side VNG-L Small	2	35	2-00270	Elbow, 3/8" Male Pipe	1
4	90-50033	Latch, Vise Action	8	36	5-3208	Unloader, AL 607, 7.8 GPM	1
5	2-011041	Trim w/Sponge /Ft.	55		5-3209	Unloader, w/Switch, Auto Start Option	1
6	95-07163034	L-Bracket, VNG	8	37	5-1025	Motor 15 HP 3 PH, 6-3, 8-25, 3 PH	1
7	90-4001	Washer, 5/16" Flat SAE	17		5-10251	Motor 15 HP 3 PH, 200V, 6-3H, 8-25H	1
8	90-1001	Bolt, 1/4" x 3/4"	17		5-1024	Motor 15 HP 3 PH 575V, 6-3, 8-25 575V	1
9	95-07163032	Brace, VNG, Elec. Box	1	38	5-406040	Pulley, 2TB40, Motor, 6-3, 8-25	1
10	2-3014	Valve, Fluidmaster, 400A	2	39	5-40505501	Pulley, 2 BK SSH Pump, 6-3	1
11	2-01164	Tank, Plastic, Universal, Float	1		5-40506701	Pulley, 2 BK 67H, Pump, 8-25	1
12	2-0151	Plug, Float Tank	1	40	5-512024	Bushing, 24mm, Pump, 6-3, 8-25	1
13	2-1906	Strainer, 1/2" Basket	1	41	5-522158	Bushing, P1 x 1-5/8" Motor	1
14	2-1024	Elbow, 1/2" Street	1	42	5-604046	Belt BX46, 6-3	2
15	2-010050	Bulkhead, 3" FT x FT	1		5-604042	Belt BX42, 8-25	2
16	2-0100379	Adapter, 3/4" x 3/4" MT x Insert 90°	1	43	4-05088	Thermostat, General	1
17	4-02100045	Inlet Hose, 45" Water Supply	1	44	95-07101225	Block, Discharge Brass 3/8" x 1/2"	1
18	4-02100030	Inlet Hose, 30" Water Supply	1	45	2-3400	Adapter, Burst Seal	1
19	4-02120000	Hose, 3/4" Push-On	8	46	2-3480	Disk, Rupture Replacement 8000 PSI	1
20	2-11050	Swivel, 3/4" Fem Push-On	2	47	2-1081	Bushing, 3/4" x 1/2"	1
21	2-10630	Elbow, 3/4" JIC x 1/2" 90 DGR	1	48	2-10813	Bushing, 1" x 3/4"	1
22	2-1062	Elbow, 1/2" JIC x 1/2", 90 DGR	1	49	5-2306	Pump, TS2021-L, 6-3	1
23	2-1053	Nipple, 1/2" JIC x 1/2" Pipe	2		5-2308	Pump, MD-15, 8-25	1
24	2-1042	Tee, 1/2" Street	3	50	2-0028	Elbow 1/2" 90 DGR Fem. Pipe	1
25	2-1076	Bushing, 1/2" x 1/4"	1	51	90-19942	Screw 10/32" x 3/4" HEX	8
26	2-1089	Hose Barb, 1/4" Barb x 1/4" 90 DGR	1	52	90-300210	Screw 1/4" x 3/4" TEK	3
27	2-9000	Clamp, Screw #4	4	53	2-90041	Clamp, Screw #16	1
28	90-017	Nut, 10/32" KEPS	5	54	6-04110	Box, Junction 3 Hole, 3/4"	1
29	90-2022	Nut Cage	7	55	2-0052	Nipple, 1/2" JIC x 1/2"	1
30	2-1105	Swivel, 1/2" JIC Fem, Push-On	2	56	2-0079	Swivel, 1/2" JIC Fem	1
31	4-02110000	Hose, 1/2" Push-On	2				
32	2-0053	Elbow, 1/2" JIC x 3/8" 90 DGR	6				

**VNG-L EXPLODED VIEW, 6-3000 • 8-2500
PARTS LIST (CONTINUED)**

ITEM	PART NO.	DESCRIPTION	QTY
57	95-07163042	Power, Plate VNG-L	1
58	95-071211125	Pump & Gen Rail, Heavy Duty	1
59	90-2002	Nut, 3/8" ESNA	15
60	90-4002	Washer, 3/8" Flat	10
61	2-0108	Bumper, Pad	21
62	2-01041	Pad, Soft Rubber	7
63	2-11041	Connector, 1/2" Anchor	1
64	2-10942	Swivel, 1/2" MP x 3/4" GHF	1
65	2-2017	Nipple, 1/2" Male	1
66	95-07163083	Wrap Outer, 30" VNG-L	1
67	95-07121222	Coil, 25" Dia, VNG-L	1
68	7-014834	Insulation, Tank Head, 30"	1
69	95-071630751	Top, Burner Wrap 30"	1
70	95-07163016	Cover, Burner Access, VNG-L	1
71	7-70151	Ignition, Control, Elec	1
72	95-07163014	Panel, Burner End VNG-L	1
73	4-02130050	Hose, 7/8" Push-On Conduit	4
74	4-02067770	Hose, 1/2" x 70"	1
75	4-02067746	Hose, 1/2" x 46"	1
76	90-10225	Bolt, 3/8" x 3-1/2" TAP	2
77	2-1902	Strainer Inlet, Garden Hose	1
78	2-0008	Nipple, 1/2" HEX	1
79	6-021730	Switch, Flow MV-60	1

VNG-L BURNER ASSEMBLY

6-3000 • 8-25006-3000 • 8-2500

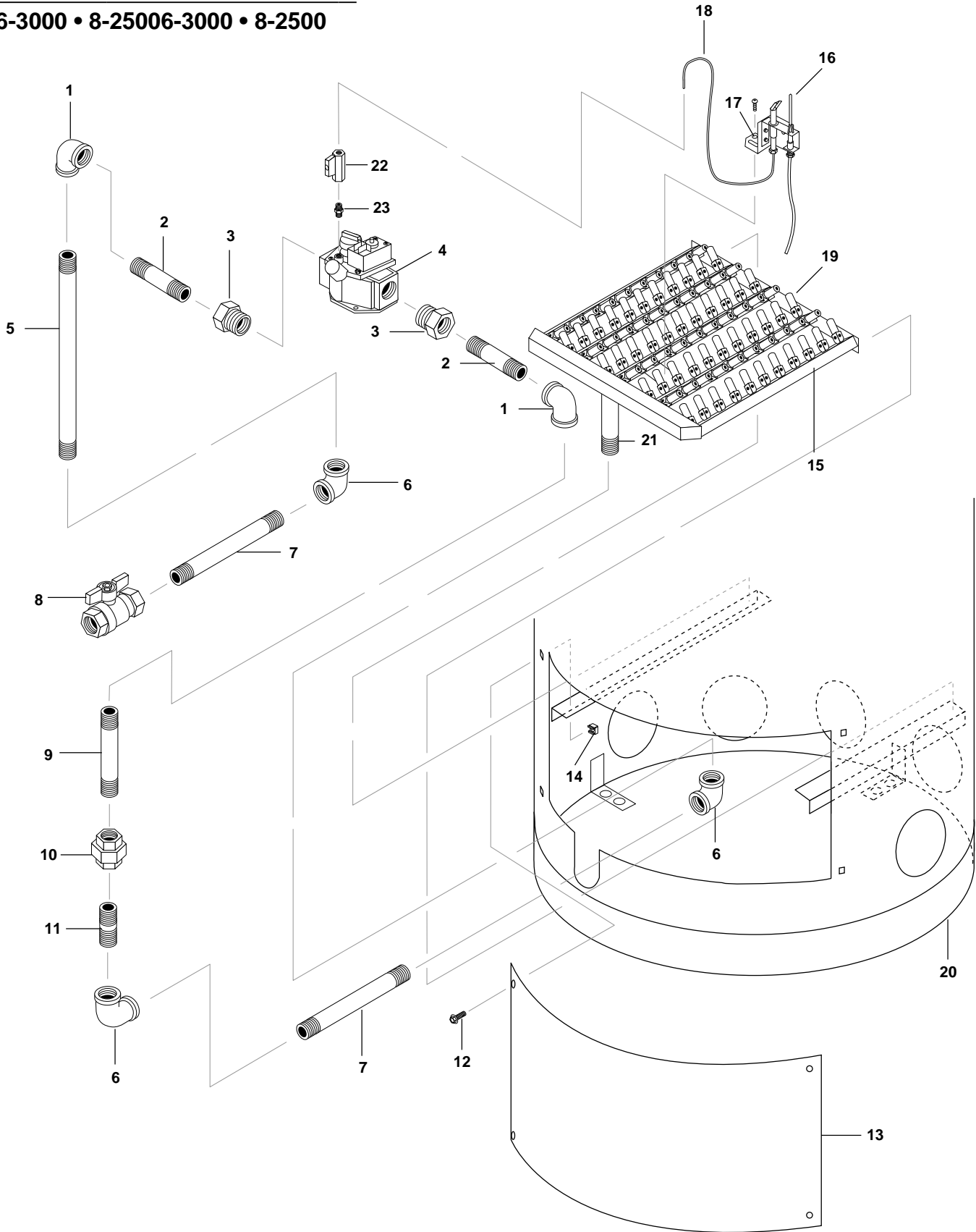

VNG-L BURNER ASSEMBLY PARTS LIST, 6-3000 • 8-2500

ITEM	PART NO.	DESCRIPTION	QTY	ITEM	PART NO.	DESCRIPTION	QTY
1	2-00295	Elbow, 1" x 3/4" Reducing, Blk	2	13	95-07163084	Door, Burner, Large, ENG/VNG	1
2	2-00162	Nipple 3/4" x 3", Black Pipe	2	14	90-19710	Nut, Cage, 1/4" x 12 GA	4
3	2-001359	Bushing, 1" x 3/4" Black Steel Hex	2	15	95-07163069	Burner Square, Assy Landa Less Jets	1
4	7-70002	Valve, Gas, 7000 DERHC	1	16	7-70236	Pilot, Natural Gas Electronic	1
5	95-07163077	Pipe, 1" NPT x 18 Blk Sch.40	1	17	95-07163085	Splash Guard, Pilot Light ENG/VNG	1
6	2-00291	Elbow, 1", Black Pipe, 90°	3	18	7-0150	Tubing, Aluminum 1/4" /per in 36	
7	2-00139	Nipple, 1" x 8" Black Pipe	2	19	7-7022	Jet, Orifice #69 Drill out to LP	99
8	7-7012	Valve, Gas Shut-Off 1" NPT	1		7-2030	Jet Orifice #54 NG	1
9	95-07163078	Pipe, 1" NPT x 11", Black Pipe, Sch.40	1		7-2022	Jet Orifice #69 LP (See Chart Page 39)	1
10	2-0086	Union, 1", Black Pipe	1	20	95-07163083	Wrap, Outer, 30" ENG/VNG Large Coil	1
11	2-00171	Nipple, 1" , Close, Black Pipe	1	21	2-00134	Pipe 1" x 4"	1
12	90-19710	Screw, 1/4" x 3/4" HH NC, Whiz Loc	4	22	2-3006	Valve, 1/4" Jomar T-91LP Ball	1
				23	2-1118	Connector Tube, 1/4" x 1/4" MPT	1

VNG6-3000 PUMP ASSEMBLY

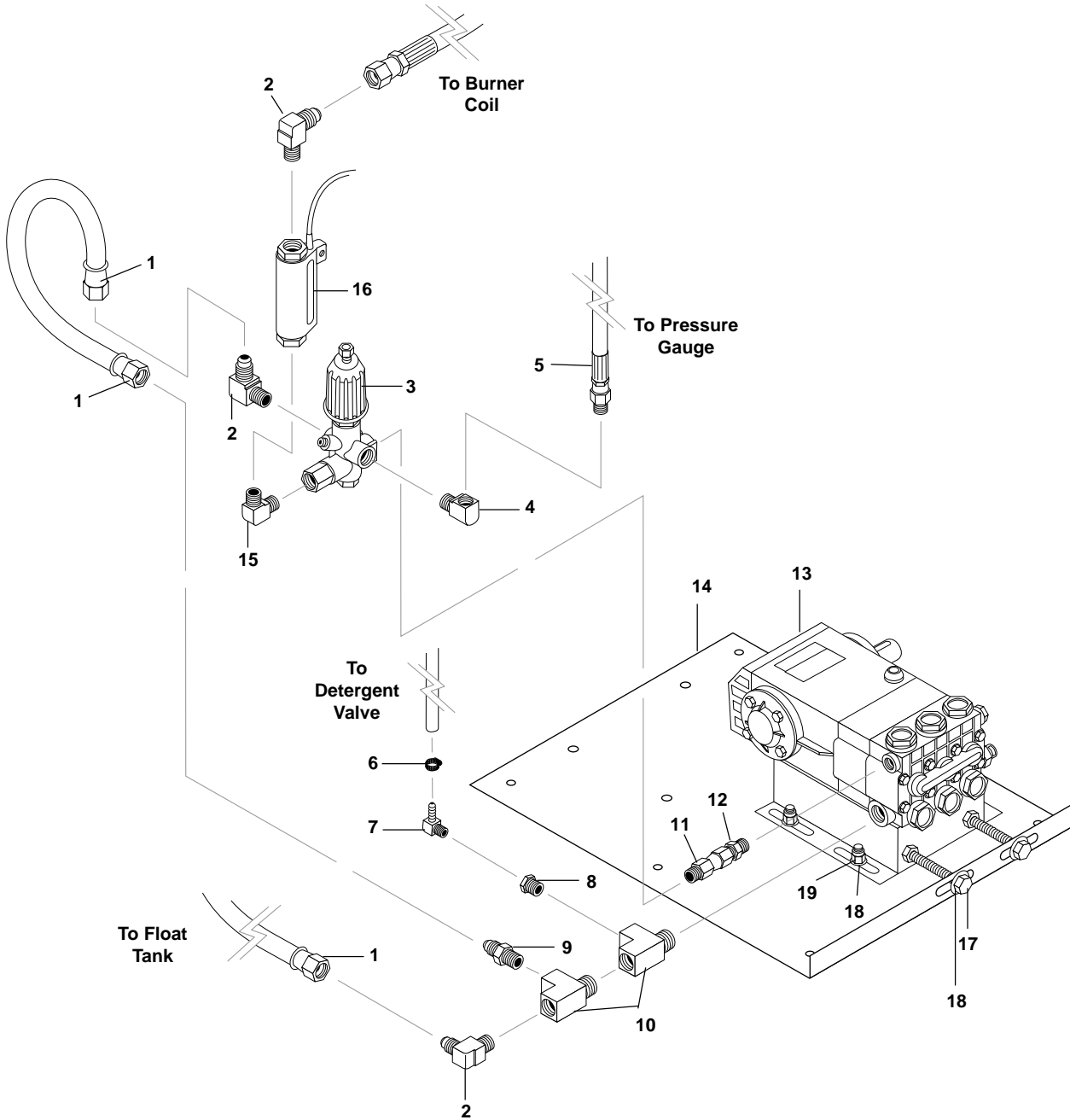

**VNG6-3000 PUMP ASSEMBLY
PARTS LIST**

ITEM	PART NO.	Description	QTY
1	2-1105	Swivel, 1/2" JIC, Female Push-on	3
2	2-1060	Elbow, 1/2" JIC x 3/8", 90°	2
3	5-3208	Unloader, AL607, 7.8 GPM	1
	5-3209	Unloader, AL687L w/Switch, Auto Start Option	1
4	2-1022	Elbow, 1/4" Street	1
5	4-02021236	Hose, 1/4" x 36" 2 Wire Gauge	1
6	2-9000	Clamp, Screw, #4	1
7	2-1089	Barb, Hose, 1/4" Barb x 1/4", Pipe, 90°	1
8	2-1076	Bushing, 1/2" x 1/4" Pipe	1
9	2-1053	Nipple 1/2" JIC x 1/2" Pipe	1
10	2-1042	Tee, 1/2" Street	2
11	2-0079	Swivel, 1/2" JIC Fem	1
12	2-0052	Nipple, 1/2" JIC x 1/2" Pipe	1
13	5-2306	Pump, General, TS-2021-L, 6-3	1
14	95-07163042	Power, Plate VNG-L	1
15	2-00270	Elbow, 3/8" Male Pipe	1
16	6-021730	Switch Flow MV 60	1
17	90-10225	Bolt, 3/8" x 3-1/2" Tap	2
18	90-4002	Washer, Flat 3/8"	2
19	90-2002	Nut 3/8" ESNA NC	4

**VNG ELECTRICAL BOX
AUTO START / STOP**

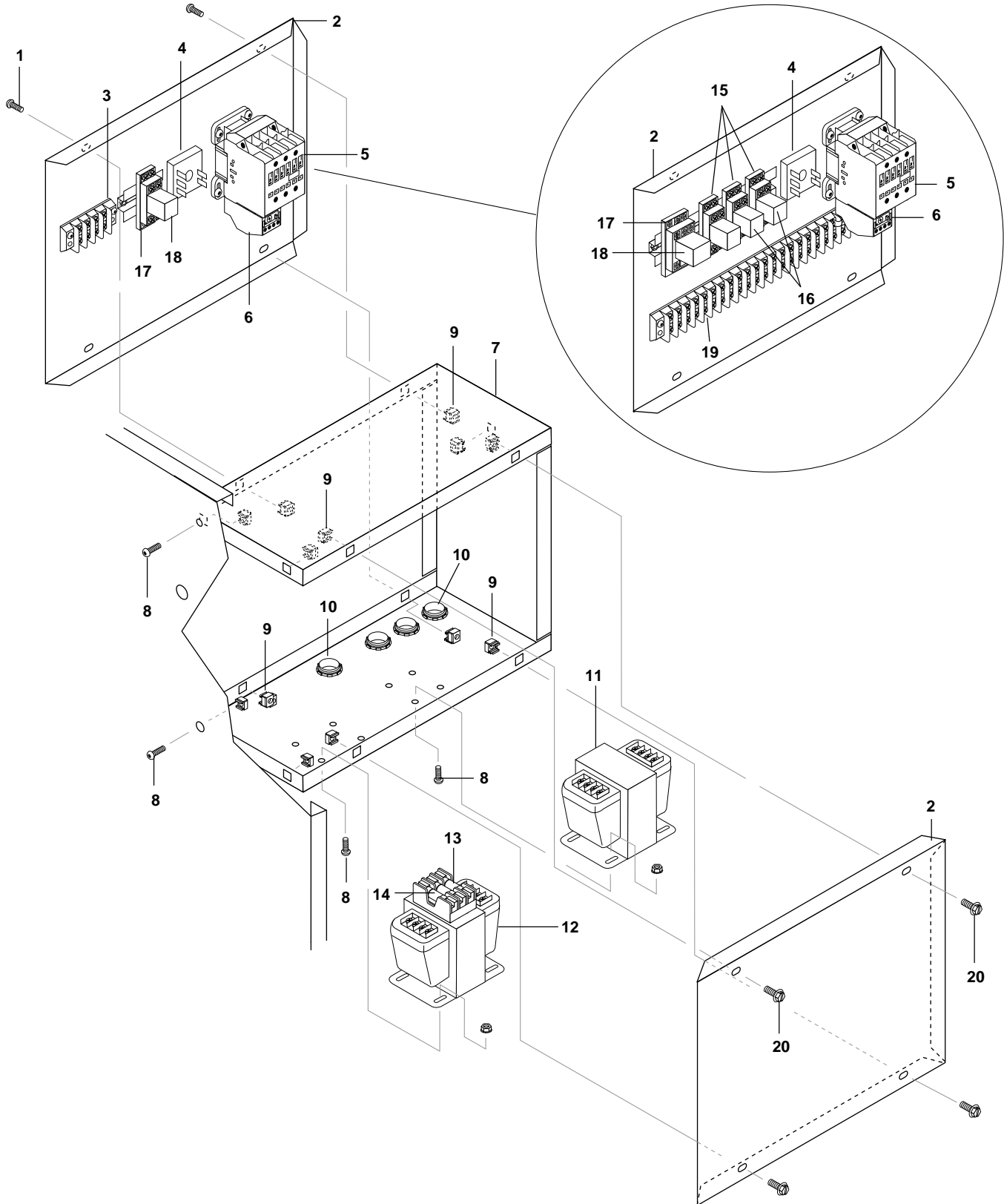

VNG ELECTRICAL BOX AUTO START • PARTS LIST

ITEM	PART NO.	DESCRIPTION	QTY
1	90-1991	Screw 10/32" x 1/2" BHSOC	22
2	95-07163030	Panel, Elec. Box, Side	2
3	6-0504	Block, Terminal, 4 Pole	1
4	6-036880	Timer, Solid State 120V, 5-60 min Lockout	1
5	6-4013	Contactora, CH (3-11)	1
	6-4018	Contactora, CH (4-2A,G, 4-3A,G, 6-3B,H, 8-25B,H)	1
	6-4000	Contactora, CH, (4-2C, 4-2F, 4-3F)	1
	6-4010	Contactora, CH (4-3B,G, 6-3C,F, 8-25C,F)	1
	6-4004	Contactora, CH (4-3C)	1
6	6-5010	Overload Relay, CH (4-3C)	1
	6-5011	Overload Relay, CH (4-2B,G)	1
	6-5012	Overload Relay, CH (6-3C, 8-25C)	1
	6-5013	Overload Relay, CH (4-31B)	1
	6-5015	Overload Relay, CH (4-3A, 6-3B, 8-25B)	1
	6-5009	Overload Relay, CH (4-2C, 4-2F, 4-3F)	1
7	95-07163028	Box, Electrical VNG	1
8	90-1998	Screw, 1/4" x 3/4" BH SOC	4
9	90-2018	Nut, Cage 10/32" x 16 GA	8
10	6-0517	Strain Relief, 3/4"	4
11	6-60121	Transformer, .050 KVA, 110-24V	1
12	6-60111	Transformer, 240/480-120V .075 KVA	1
13	6-02295	Fuse, ATMR 1/2 Amp, 480V	2
	6-02294	Fuse, ATMR 1 Amp, 240V	2
14	6-0229810	Fuse, Paper, Buss. FNM-8/10 250V Midget TD	1
15	6-03541	Base, Relay IDEC, Remote	3
16	6-03621	Relay, 120V, Idec, Remote	3
17	6-035210	Relay, Socket Idec, Remote	1
18	6-036210	Relay, Latch, 2 Idec, Remote	1
19	6-05041	Block, Terminal, 16 Pole, Remote	1
20	90-19942	Screw, 10/32" x 3/4" Hex	4

**VNG ELECTRICAL BOX
TIME DELAY**

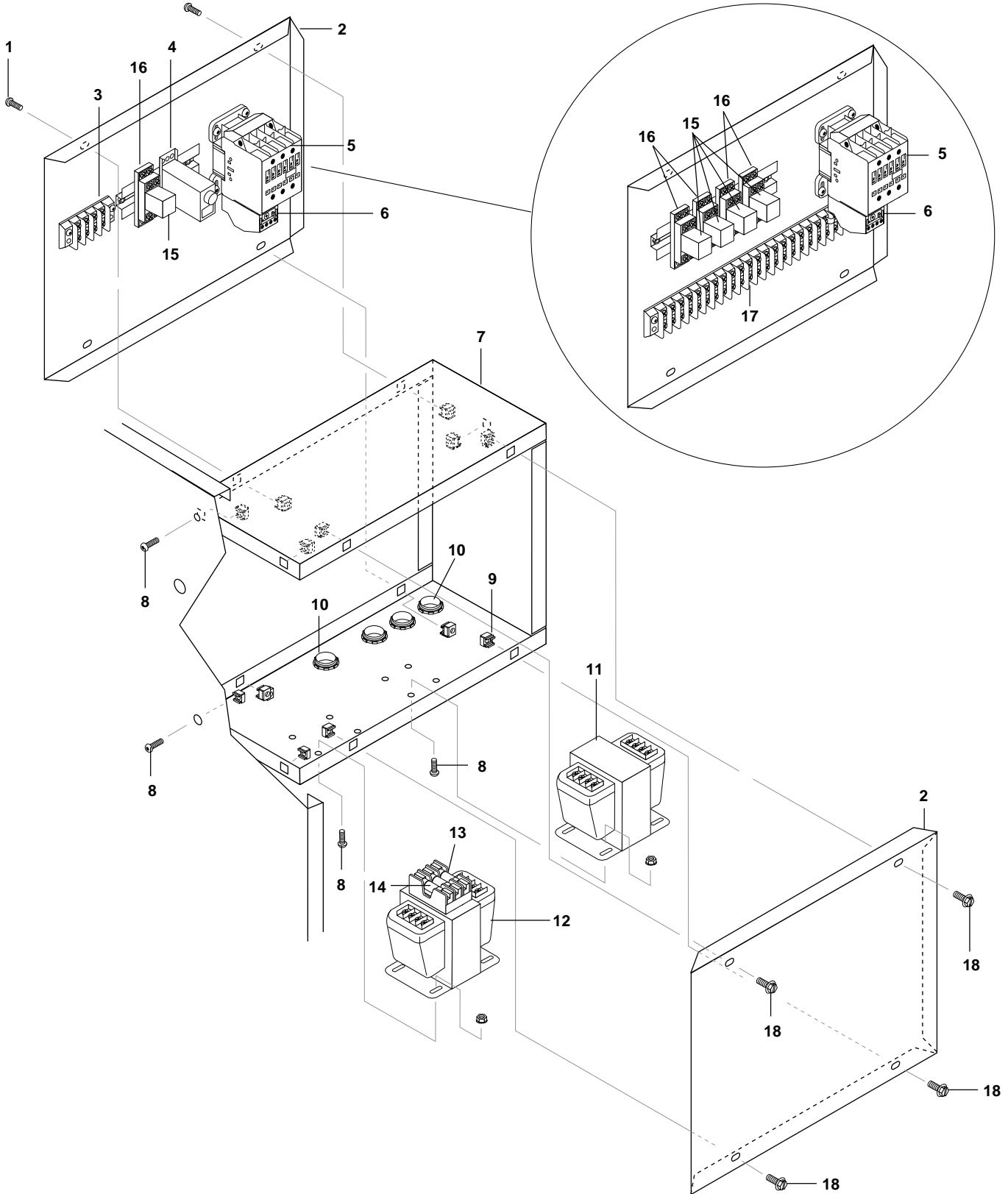

**VNG ELECTRICAL BOX
TIME DELAY • PARTS LIST**

ITEM	PART NO.	DESCRIPTION	QTY
1	90-1991	Screw 10/32" x 1/2" BHSOC	22
2	95-07163030	Panel, Elec. Box, Side	2
3	6-0504	Block, Terminal, 4 Pole	1
4	6-03700	Timer, Multi Function 24V - 120/240V	1
5	6-4013	Contactora, CH (3-11)	1
	6-4018	Contactora, CH (4-2A,G, 4-3A,G, 6-3B,H, 8-25B,H)	1
	6-4000	Contactora, CH, (4-2C, 4-2F, 4-3F)	1
	6-4010	Contactora, CH (4-3B,G, 6-3C,F, 8-25C,F)	1
	6-4004	Contactora, CH (4-3C)	1
	6-4007	Contactora, CH (4-2B)	1
6	6-5010	Overload Relay, CH (4-3C)	1
	6-5011	Overload Relay, CH (4-2B,G)	1
	6-5012	Overload Relay, CH (6-3C, 8-25C)	1
	6-5013	Overload Relay, CH (4-3B)	1
	6-5015	Overload Relay, CH (4-3A, 6-3B, 8-25B)	1
	6-5009	Overload Relay, CH (4-2C, 4-2F, 4-3F)	1
7	95-07163028	Box, Electrical VNG	1
8	90-1998	Screw, 1/4" x 3/4" BH SOC	4
9	90-2018	Nut, Cage 10/32" x 16 GA	8
10	6-0517	Strain Relief, 3/4"	4
11	6-60121	Transformer, .050 KVA, 110-24V	1
12	6-60111	Transformer, 240/480-120V .075 KVA	1
13	6-02295	Fuse, ATMR 1/2 Amp, 480V	2
	6-02294	Fuse, ATMR 1 Amp, 240V	2
14	6-0229810	Fuse, Paper, Buss FNM-8/10, 250V Midget TD	1
15	6-03541	Base, Relay IDEC, Remote	3
16	6-03621	Relay, 120V, Idec, Remote	3
17	6-05041	Block, Terminal, 16 Pole, Remote	1
18	90-19942	Screw, 10/32" x 3/4" Hex	4

**VNG REMOTE ELECTRICAL BOX
ALL MODELS**

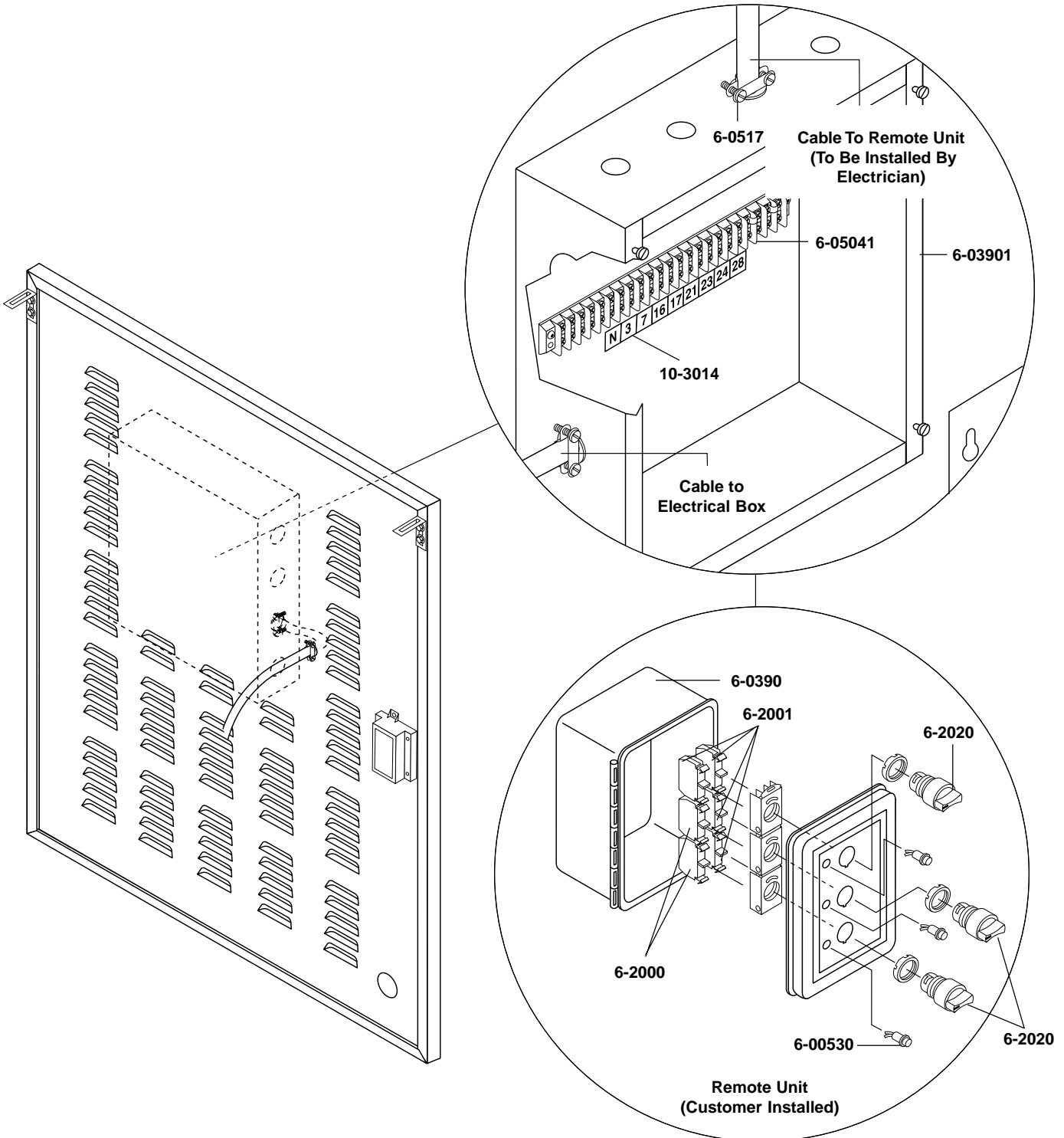

TROUBLESHOOTING — BURNER

PROBLEM	POSSIBLE CAUSE	SOLUTION
FLOW & BURNER SWITCH ON; NO SPARK, NO PILOT GAS	A. No main power	With power switch on, open trigger on spray gun and set your test meter to the 24 volt scale. Probe terminals TH and GND. If you do not read 24 volts, the problem is not the ignition system. Perform normal system checks of main power, transformer, thermostat and the limit control. If you do read 24 volts at TH and GND, the problem is in the ignition system. Check for loose or defective wiring. If wiring is good, replace the ignition control unit.
	B. Faulty transformer	
	C. Faulty burner & flow switch	
	D. Faulty ignition control unit	
HAVE SPARK, NO PILOT GAS FLOW	Main gas supply turned off	Set test meter to 24 volt scale.
		1. Be sure main gas valve (gas cock or selector arm) is turned on.
		2. With gas on and system sparking, probe terminals PV and GND. If pilot gas does not flow with 24 volts at these terminals, replace gas valve.
		3. Probe terminals PV and MV/PV. If 24 volts not present, replace ignition control box.
HAVE PILOT GAS, NO SPARK	A. Defective ignitor/sensor and or its wiring	Set test meter to ohm scale.
		1. Disconnect the wire from the IGN terminal on the ignition control unit.
	B. Faulty ignition control unit	2. Touch one meter probe to the tip of the ignitor/sensor rod in the pilot. Touch the other probe to the quick connect at the other end of ignitor/sensor wire.
		3. If you have continuity from the tip of the ignitor/sensor rod to the connector and no spark, replace the ignition control unit.
		4. If you do not have continuity through wire and the ignitor/sensor, check for a loose wire connection in the wire. Repair as needed.
5. Check to see if spark shorts to burner ring through a cut in the ignitor wire.		

TROUBLESHOOTING — BURNER (Continued)

PROBLEM	POSSIBLE CAUSE	SOLUTION
HAVE PILOT FLAME, MAIN BURNER WILL NOT TURN ON	Faulty main valve coil in the gas valve	Set test meter to 24 volt scale.
	Faulty ignitor/sensor and/or its wiring	With pilot flame on ignitor/sensor, probe terminals MV and MV/PV on the ignition control unit. If you read 24 volts here, but not at the gas valve, there is a loose wiring connection. Repair or replace as needed.
	Ground wire not attached to machine chassis	If you do read 24 volts at MV and MV/PV and the pilot flame is impinging on the ignitor/sensor rod, the problems may be:
	Faulty ignition control unit	a. Faulty ignitor/sensor and/or its wiring.
		b. Faulty ignition control unit.
		Set test meter to the ohm scale. Turn burner switch off.
Check continuity through the green ground wire and its connections.		
	Reconnect the ignitor/sensor wire and the ground wire.	
	Turn burner switch on. With the pilot burning and the flame on the ignitor/sensor rod, the main burner should turn on. If it does not, replace the ignition control unit.	
SHORT-CYCLING OF MAIN BURNER. MAIN BURNER TURNS OFF BEFORE THE BURNER SWITCH OR FLOW SWITCH IS TURNED OFF	Draft condition pulls flame away from ignitor/sensor rod.	Check the thermostat by bypassing at terminals P1 & 1.
		Set thermostat high. With main burner on, observe the pilot flame impingement on the ignitor/sensor.
	Faulty thermostat or water temperature is too high	If pilot flame is small and draft condition pulls flame from ignitor sensor rod, the burner will turn off and then on again. a. Adjust pilot flame higher or clean pilot orifice. b. Bend ignitor/sensor rod closer to pilot flame.
		If flame impingement on the ignitor/sensor is stable and the system short-cycles, check the limit switch.
		Set test meter to 110 volt scale a. When the system cycles off, probe the switch terminals of the limit switch. b. If you read 24V across the switch terminals the limit switch is open. Replace the limit switch.
	A pilot flame set too high will also cause burner to short cycle. Pilot flame lifts over ignitor/sensor.	

TROUBLESHOOTING

PROBLEM	POSSIBLE CAUSE	SOLUTION
LOW OPERATING PRESSURE	Faulty pressure gauge	Install new gauge.
	Insufficient water supply	Use larger garden hose; clean filter washer at water inlet.
	Old, worn or incorrect spray nozzle	Match nozzle number to machine and/or replace with new nozzle.
	Belt slippage	Tighten or replace; use correct belt.
	Plumbing or hose leak	Check plumbing.
	Faulty or misadjusted unloader valve (where applicable)	Adjust unloader for proper pressure. Install repair kit when needed.
	Worn packing in pump	Install new packing kit.
	Fouled or dirty inlet or discharge valves in pump	Clean inlet and discharge valves.
	Worn inlet or discharge valves	Replace with valve kit.
	Obstruction in spray nozzle	Remove obstruction.
	Leaking pressure control valve (where applicable)	Rebuild or replace as needed.
	Detergent metering valve left open sucking air, or faulty metering valve	Close and/or replace metering valve.
	Slow motor RPM	Check incoming voltage.
LOW WATER TEMPERATURE	Improper size of gas lines	See page 8 for sizing of gas lines.
	Low gas pressure	Increase gas pressure to machine.
	Improper pressure regulator	Specify BTU, building gas pressure and 11" wc to machine for correct sizing of regulator.
	Low gas valve pressure	Increase gas pressure as described on pages 13-14.
	Soot buildup on coils not allowing heat transfer	Clean coils.
	Improper burner nozzle	See exploded view parts list.

TROUBLESHOOTING

PROBLEM	POSSIBLE CAUSE	SOLUTION
WATER TEMPERATURE TOO HOT	Incoming water to machine warm or hot	Lower incoming water temperature.
	Gas pressure too high	Call local gas company.
	Detergent line sucking air	Tighten all clamps Check detergent lines for holes.
	Defective high limit switch	Replace.
	Incorrect burner nozzle size	See exploded view parts list.
	Insufficient water supplied	Check water G.P.M. to machine.
	Restricted water flow	Check nozzle for obstruction, proper size.
DETERGENT NOT DRAWING	Air leak	Tighten all clamps. Check detergent lines for holes.
	Detergent metering valve packing not tight or packing worn	Tighten nut. Replace valve or packing.
	Filter screen on detergent suction hose plugged	Clean or replace.
	Dried up detergent plugging metering valve	Disassemble and clean thoroughly.
	High viscosity of detergent	Dilute detergent to specifications.
	Restriction behind float tank screen removed	Install restriction.
	Hole in detergent line(s)	Repair hole.
	Strainer basket plugged	Remove and clean.
	Connections on selector valve loose	Put teflon tape on all pipe connections.
	Detergent solenoid not opening (where applicable)	Check flow switch, replace detergent solenoid.
PUMP RUNNING NORMALLY BUT PRESSURE LOW ON INSTALLATION	Pump sucking air	Check water supply and possibility of air seepage.
	Valves sticking	Check and clean or replace if necessary.
	Unloader valve seat faulty	Check and replace if necessary.
	Nozzle incorrectly sized	Check and replace if necessary (see serial plate for proper size).
	Worn piston packing	Check and replace if necessary.

TROUBLESHOOTING

PROBLEM	POSSIBLE CAUSE	SOLUTION
FLUCTUATING PRESSURE	Valves worn	Check and replace if necessary.
	Blockage in valve	Check and replace if necessary.
	Pump sucking air	Check water supply and air seepage at joints in suction line
	Worn piston packing	Check and replace if necessary.
PUMP NOISY	Air in suction line	Check water supply and connections on suction line.
	Broken or weak inlet or discharge valve springs	Check and replace if necessary.
	Excessive matter in valves	Check and clean if necessary.
	Worn bearings	Check and replace if necessary.
PRESENCE OF WATER IN OIL	Oil seal worn	Check and replace if necessary.
	High humidity in air	Check and change oil twice as often.
WATER DRIPPING FROM UNDER PUMP	Piston packing worn	Check and replace if necessary.
	O-ring plunger retainer worn	Check and replace if necessary.
OIL DRIPPING	Oil seal worn	Check and replace if necessary.
EXCESSIVE VIBRATION IN DELIVERY LINE	Irregular functioning of the valves	Check and replace if necessary.
RELIEF VALVE LEAKS WATER	Relief valves defective	Replace or repair.

BASIC FACTS

BASED ON 60° F	PROPANE	BUTANE
Formula	C3H8	C4H10
Vaporization Point (°F)	-43.7	31.1
Specific Gravity (Vapor)	1.522	2.006
Specific Gravity (Liquid)	0.508	0.584
Lbs. Per Gallon (Liquid)	4.23	4.87
B.T.U. Per Cubic Foot (Vapor)	2.563	3.39
B.T.U. Per Lb. (Vapor)	21.663	21/3-9
B.T.U. Per Gallon (Liquid)	91.74	1-3/93
Cubic Feet Per Lb. (Liquid)	8.607	7/53
Cubic Feet Per Gallon (Liquid)	3.45	31/9
Octane Number	125	1
Molecular Weight	44.09	58.12
To calculate running cost:		
1 cubic Ft./1,000 B.T.U.		
100 cubic Ft./Therm		
Therm/Hour		
50¢ Therm		
Example:	Using natural gas	
	400,000 BTU Machine	
	400 cubic feet	
	4 Therms/hour	
	4 x .50 = \$2.00/hour to run	

PRESSURE EQUIVALENTS

Simply stated, pressure is the force exerted by a gas or liquid attempting to escape from a container. It is useful to know how strong this "attempt to escape" is. Pressure can be measured with a manometer or with a pressure gauge. At the lower levels, it is expressed in "inches of water column" i.e. 1" w.c. Higher pressures are expressed in terms of the force exerted against a square inch of area. For example, 125 lbs. per square inch (125 psi).

1" Water Column	=	50 Oz./Sq. In.	11" Water Column	=	6.35 Oz./Sq. In.
11" Water Column	=	4 Lb./Sq. In.	1 Lb./Sq. In.	=	27.71" Water Column
1 Lb./Sq. In.	=	2.04" Mercury	1" Mercury	=	.39 Lb./Sq. In.
1 Std. Atmosphere	=	14.73 Lbs./Sq. in			

BURNER SPECIFICATIONS

MODEL	BURNER ASSEMBLY	JET SIZE	GAS VALVE	PILOT ORIFICE CONVERSION
VNG3-1000	X-46	#56	3/4" 7000MV4HC	No
VNG4-2000	X-46	#54	3/4" 7000MVRHC	No
VNG4-3000	X-46	#54	3/4" 7000MVRHC	No
VNG6-3000	EW-98	#54	1" 7000MVRHC	No
VNG8-2500	EW-98	#54	1" 7000MVRHC	No
VLP3-1000	X-46	#69	3/4" 7000MV4HC Kit	Yes
VLP4-2000	X-46	#65	3/4" 7000MV4HC-LP Kit	Yes
VLP4-3000	X-46	#65	3/4" 7000MV4HC-LP Kit	Yes
VLP6-3000	EW-98	#66	1" 7000MV4HC-LP Kit	Yes
VLP8-2500	EW-98	#66	1" 7000MV4HC-LP Kit	Yes



LANDA LIMITED NEW PRODUCT WARRANTY PRESSURE WASHERS

WHAT THIS WARRANTY COVERS

All LANDA pressure washers are warranted by LANDA, INC. to the original purchaser to be free from defects in materials and workmanship under normal use, for the periods specified below. This Limited Warranty is subject to the exclusions shown below, is calculated from the date of the original purchase, and applies to the original components only. Any parts replaced under this warranty will assume the remainder of the part's warranty period.

FIVE YEAR PARTS AND ONE YEAR LABOR WARRANTY:

Components manufactured by Landa, such as frames, handles, top and bottom wraps, float tanks, fuel tanks, belt guards, and coils. Internal components on the oil-end of all pressure washer pumps.

ONE YEAR MINIMUM ON PARTS AND ONE YEAR LABOR WARRANTY:

All other components, excluding normal wear items as described below, will be warranted for one year on parts and labor. Parts and labor warranty on these parts will be for one year regardless of the duration of the original component manufacturer's part warranty.

WARRANTY PROVIDED BY OTHER MANUFACTURERS:

Motors, generators, and engines, which are warranted by their respective manufacturers, are serviced through these manufacturers' local authorized service centers. LANDA cannot provide warranty on these items.

WHAT THIS WARRANTY DOES NOT COVER

This warranty does not cover the following items:

1. Normal wear items, such as nozzles, guns, discharge hoses, wands, quick couplers, seals, filters, gaskets, O-rings, packings, pistons, pump valve assemblies, strainers, belts, brushes, rupture disks, fuses, pump protectors.
2. Damage or malfunctions resulting from accidents, abuse, modifications, alterations, incorrect installation, improper servicing, failure to follow manufacturer's maintenance instructions, or use of the equipment beyond its stated usage specifications as contained in the operator's manual.
3. Damage due to freezing, chemical deterioration, scale build up, rust, corrosion, or thermal expansion.
4. Damage to components from fluctuations in electrical or water supply.
5. Normal maintenance service, including adjustments, fuel system cleaning, and clearing of obstructions.
6. Transportation to service center, field labor charges, or freight damage.

WHAT YOU MUST DO TO OBTAIN WARRANTY SERVICE

While not required for warranty service, we request that you register your LANDA pressure washer by returning the completed registration card. In order to obtain warranty service on items warranted by LANDA, you must return the product to your Authorized LANDA Dealer, freight prepaid, with proof of purchase, within the applicable warranty period. If the product is permanently installed, you must notify your Authorized LANDA Dealer of the defect. Your Authorized LANDA Dealer will file a claim with Landa, who must subsequently verify the defect. In most cases, the part must be returned to LANDA freight prepaid with the claim. For warranty service on components warranted by other manufacturer's, your Authorized LANDA Dealer can help you obtain warranty service through these manufacturers' local authorized service centers. If you are unable to resolve the warranty claim satisfactorily, write to LANDA at 4275 N.W. Pacific Rim Blvd., Camas, WA 98607, ATTN: Warranty Dept., detailing the nature of the defect, the name of the Authorized LANDA Dealer, and a copy of the purchase invoice.

LIMITATION OF LIABILITY

LANDA'S liability for special, incidental, or consequential damages is expressly disclaimed. In no event shall LANDA'S liability exceed the purchase price of the product in question. LANDA makes every effort to ensure that all illustrations and specifications are correct, however, these do not imply a warranty that the product is merchantable or fit for a particular purpose, or that the product will actually conform to the illustrations and specifications. **THE WARRANTY CONTAINED HEREIN IS IN LIEU OF ALL OTHER WARRANTIES, EXPRESS OR IMPLIED, INCLUDING ANY IMPLIED WARRANTY OF FITNESS FOR A PARTICULAR PURPOSE.** LANDA does not authorize any other party, including authorized LANDA Dealers, to make any representation or promise on behalf of LANDA, or to modify the terms, conditions, or limitations in any way. It is the buyer's responsibility to ensure that the installation and use of LANDA products conforms to local codes. While LANDA attempts to assure that its products meet national codes, it cannot be responsible for how the customer chooses to use or install the product.



4275 NW Pacific Rim Blvd. • Camas, WA 98607 USA

Form #96-610 • Revised 7/01 • Printed in U.S.A. by Landa, Inc., Camas, WA 98607