



OPERATOR'S MANUAL

■ REC2-20 Water Treatment System



89174360-1

Patent Pending

For the dealer nearest you, consult our web page at www.wmaze.com

8.917-436.0

CONTENTS

Introduction and Important Safety Issues.....	3-4
Application and Intended Use	5
Installation & Operating Instructions	6
Pressure Switch and Pressure Tank Operation	7
Maintenance Instructions	8
Rec2-20 Component Identification.....	9
Piping Connection Diagram	10
Float Connection Diagram	11
Digital Timer Instructions.....	12-13
Operation and Maintenance.....	14
Troubleshooting Guides.....	15-19
Body Exploded View and Parts List	20-21
Cabinet Exploded View and Parts List.....	22-23
Electrical Box Exploded View and Parts List.....	24-25
Control Panel Exploded View & Parts List	26
Junction Box Exploded View and Parts List.....	27
Right Side Panel Exploded View and Parts Lists.....	28-29
Plumbing Exploded View and Parts List	30-31
Transfer/Ozone Pump Exploded View and Parts List.....	32-33
Junction Box wiring diagram.....	34
Ozone Generator Maintenance, Exploded View & Parts List.....	35-38
Warranty Accessories and Parts	
Warranty Water Treatment Systems Warranty	

Part Number _____

Serial Number _____ Code _____

Date of Purchase _____

The part and serial numbers will be found on a decal attached to the machine. You should record both serial number and date of purchase and keep in a safe place for future reference.

INTRODUCTION & IMPORTANT SAFETY INSTRUCTIONS

Your owner's manual has been prepared to provide you with a simple and understandable guide, for equipment operation and maintenance, based on the latest product information available at the time of printing. To keep your machine in top running condition follow the specific maintenance and troubleshooting procedures given in this manual.

NOTE: *Water Maze* reserves the right to make changes at anytime without incurring any obligations.

Owner/User Responsibility:

The owner and/or user must have an understanding of the manufacturer's operating instructions and warnings before using this equipment. Warning information should be emphasized and understood. If the operator is not fluent in English, the manufacturer's instructions and warnings shall be read to and discussed with the operator in the operator's native language by the purchaser/owner, making sure that the operator comprehends its contents.

Owner and/or user must study and maintain for future reference the manufacturers' instructions.

This manual should be considered a permanent part of the machine and should remain with it if machine is resold.

When ordering parts, please specify model, part number and serial number.

GENERAL SAFETY INFORMATION

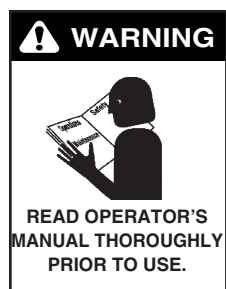

WARNING: *When using this machine basic precautions should always be followed, including the following:*

1. Read all the instructions before using the product.
2. To reduce the risk of injury, close supervision is necessary when a product is used near children.
3. Know how to stop the product and bleed pressures quickly. Be thoroughly familiar with the controls.
4. Stay alert – watch what you are doing.
5. Do not operate the product when fatigued or under the influence of alcohol or drugs.
6. Keep operating area clear of all persons.
7. Do not overreach or stand on unstable support. Keep good footing and balance at all times.
8. Follow the maintenance instructions specified in the manual.
9. Know the system application, limitations, and potential hazards.



WARNING: *This machine must be wired to the correct voltage. Refer to the information located on the serial plate.*

WARNING: *All wiring must be performed by a qualified electrician.*

WARNING: *Risk of Electric Shock*

DANGER – Improper connection of the equipment-grounding conductor can result in a risk of electrocution. Check with a qualified electrician or service personnel if you are in doubt as to whether this machine is properly grounded. Have proper power connections installed by a qualified electrician. Do not use any type of adaptor with this product.

GROUNDING INSTRUCTIONS

This product must be connected to a grounded, metal, permanent wiring system; or an equipment-grounding conductor must be run with the circuit conductors and connected to the equipment-grounding terminal located on the product in compliance with National Electrical Codes (NEC).

GROUND FAULT CIRCUIT INTERRUPTER PROTECTION

To comply with the National Electrical Code (NFPA 70) and to provide additional protection from the risk of electric shock, this machine should only be connected to a circuit protected by a ground fault circuit interrupter (GFCI).



WARNING: *Do not use near concentrations of flammable or explosive fluids such as gasoline, fuel oil, kerosene, solvents, etc. Do not use in explosive atmospheres. Liquids compatible with component materials should only be used. Failure to follow this warning can result in personal injury and/or property damage.*

10. The main power must be brought from the circuit breaker and wired into the electrical box on the Rec 2-20. This power supply must be run through conduit in compliance with local and national electrical codes. A power disconnect should be located near the machine for maintenance and emergency purposes.

IMPORTANT SAFETY INSTRUCTIONS

11. Protect all electrical wiring from sharp objects, hot surfaces, oil, sunlight, and chemicals. Avoid kinking the cords.

WARNING: If any cords or electrical wires appear to be frayed, damaged, or in poor condition, proceed with caution and immediately take steps to have the cords repaired or replaced.

12. Never make adjustments on the machine while it is in operation, except for those prescribed in this manual.
13. Follow the maintenance instructions specified in this manual.
14. Before servicing the machine, refer to all the MSDS's on the material identified in the waste stream. You must comply with all warnings and wear all protective clothing as stated on the MSDS's.
15. Inlet water temperature must not exceed 85°F.
16. The best insurance against an accident is precaution and knowledge of the equipment.
17. *Water Maze* is not liable for modifications or use of components not purchased from *Water Maze*.



18. Personal Safety:
 - a. Wear safety glasses and other applicable protective clothing at all times when working on this machine.

Refer to item #14 under Important Safety Information.

- b. Keep your work area clean, uncluttered and properly lighted
 - c. Replace all unused tools and equipment.
 - d. Keep visitors at a safe distance from work area.
19. Running the system without water will damage the pumps and will void the warranty.
20. Release all pressure within the system before servicing any component.
21. Drain all liquids from the component before servicing.

22. Check hoses for weak or worn conditions before each use, making certain that all connections are secure.
23. Periodically inspect pump and system components. Perform routine maintenance as required.
24. Do not touch an operating motor. Modern motors are designed to operate at high temperatures.
25. Do not touch any electrical component with wet hands, when standing on a wet or damp surface, or in water.
26. The pump motors are equipped with a thermal protector. Tripping is an indication of motor overloading as a result of operating at excessively high or low voltage, inadequate wiring, incorrect motor connections, or a defective motor or pump.
27. **Keep machine from freezing.**
28. Do not spray water directly at machine.

WARNING: This system contains moving parts in the control center and in the pumps. Follow safe practices when performing maintenance and when troubleshooting. Disconnect the power before servicing this machine. If the power disconnect is out of sight, lock it in the open position and tag it to prevent unexpected application of power.

WARNING: Make sure to take precautions when performing maintenance on the pump in the catch basin. Turn off the power to the pump and make sure electrical cords are well maintained.

APPLICATION AND INTENDED USE

Rec2-20 Water Management Unit:

The Rec2-20 water management unit should be installed as a **recycler to transport water between a water treatment system and local storage tank. The Rec2-20 unit can then be used to circulate and refresh stored water. An optional Ozone generator can be added further sanitize and de-odor the water. The Rec2-20 unit can also maintain water levels in the local storage tank, to prevent overflows and draining. Auxiliary parts are also available for hose and pressure washers.** The Rec2-20 should be installed as a component of a system that incorporates multiple water treatment technologies.

To assure the safety of the Rec2-20 unit, pretreatment of the waste water should be applied to remove as many solids and oils as possible prior to entering the Rec2-20.

Consult a Water Maze representative prior to combining the Rec2-20 with other pre-treating and post treating equipment.

TCLP Testing:

TCLP is one of the Federal EPA test methods that are used to characterize waste as either hazardous or non-hazardous for the purpose of disposal. TCLP is an acronym for Toxicity Characteristic Leaching Procedure. A TCLP test may be required prior to disposal of your solid waste. Consult a Water Maze representative for details.

Site Preparation:

The installation site surface should be of compacted materials, such as concrete, asphalt or pavement and capable of supporting the Rec2-20 treatment system.

INSTALLATION & OPERATING INSTRUCTIONS

The following instructions will provide adequate information to fully install your Water Maze Recycling System. Please follow these instructions step by step to ensure proper installation.

WARNING: A backflow preventer must be provided when connecting to a potable water supply to prevent back-siphonage into the water supply.

Equipment and Supplies Needed for Installation

Aside from having a general assembly of tools on hand, you will need to supply a few additional items to complete the installation of your system.

- Forklift
- Tape Measure
- Level

Equipment Installation

The model Rec2-20 water treatment system must be installed on a level surface.

- If surface is not level, shimming may be required.

Installation Checklist

- Are all piping and electrical float switches connected as shown on the Float piping and Connection Diagrams pages 10 and 11.
- Are floats connected as shown on the Junction Box wiring Diagram on page 34?
- Is the voltage correct?

START-UP

1. Make sure that all equipment is level.
2. Install float switches in infeed/sump tank and storage tank according to the Float Connection Diagram, page 11, included in this manual.
3. Connect piping according to Piping Connection Diagram, page 10, included with this manual.
4. Connect electrical power to electrical box: When connecting to the power supply, follow all electrical and safety codes as well as the most recent National Electric Code (NEC) and Occupational Safety and Health Act (OSHA). Ground system before connecting to the power supply.

WARNING: All wiring must be performed by a qualified electrician.

5. Use included Digital Timer Instructions, pages 12-13, to set clock and circulation/ozonating times.
6. Fill infeed/sump tank with water and ensure storage tank's water level is above the "Low Water Float".
7. Fill all inlet lines (two inlets from storage tank on right side and one from infeed source on left side) with water.

8. Open any valves between Rec2-20 module and storage tank, infeed/sump tank, drain, and fresh water source.

9. Press "ON" switch on control panel to begin Rec2-20 operations. To complete priming of infeed and circulation/ozone pumps, hold "ON" switch down for three seconds until light begins flashing. The flashing "ON" light indicated the machine is in a flushing routine that forces fresh water through plumbing to prime pumps. Flushing routine will last fifteen seconds, however, pumps will need to continue running for approximately one minute before they complete priming and reach capacity water flow. If pumps do not reach a high flow rate within one minute of flushing, repeat routine by holding down "ON" switch for three seconds, again.

UTILITY USAGE

Electrical: 230 Volts, 1 PH

Amps: 21.6 amps

OPERATING ENVIRONMENT

The Rec 2-20 is designed to work in a wide variety of operating conditions. In normal operating environments, the system should perform as specified. In extremely hot or cold environments certain precautions need to be taken.

Operating Conditions

Air Temperature Range 40° - 120°F

Cold Weather

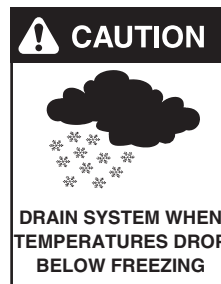

Protect the Rec 2-20 from damage that can occur when freezing water expands. Freezing water may cause pipes to burst.

Drain all pipes if a prolonged hard freeze is expected. Make sure all valves are open so water can completely drain from the system.



Cold Climate Conditions

In locations where freezing temperatures will be experienced on a regular basis or where very cold temperatures will be incurred, the water treatment system should be drained when the outside ambient temperature drops below freezing and/or the water system (Rec 2-20) should be housed in a heated structure. The warranty on the water treatment system does not provide for repair due to freezing conditions.

PRESSURE SWITCH AND PRESSURE TANK OPERATION



WARNING: Live electrical contacts are exposed, so disconnect power first and have work performed by a qualified electrician.

Remove cover of the pump pressure control switch to allow access to the two nuts used to adjust the pump operating pressure. The pressure switch on Water Maze equipment is set at the factory and should not have to be adjusted at start-up, but will need to be verified at start up and maintained regularly at least monthly.

1. The nut on the larger spring in the pump pressure switch, adjusts the pump cut in (cut on) and pump cut out (cut off) pressures simultaneously.
2. The nut atop the smaller spring in the pump pressure switch only controls the cut out range and is used to narrow or widen the gap between the pump cut in and cut out pressures.
3. To cycle the pump less frequently, the gap should be as wide as possible while still allowing the pump to shut off quickly when all outlets are closed. Adjust the smaller spring to widen the gap between pump in and out (on and off). 40-45 PSI (CLP, Rec2-20) or 30 PSI (EC1-300A) is desirable. Adjusting the larger spring should not be necessary.
4. When making pressure switch adjustments, make sure all pump outlets are off or closed, except for the one outlet valve used to relieve and build pressure while making pressure switch adjustments.

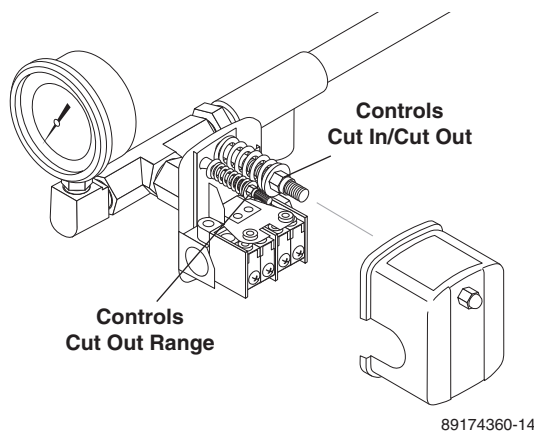

PRESSURE TANK OPERATION



WARNING! When the tank has been in service and a change to a higher pre-charge pressure is necessary because of a required change in the pressure switch setting, failure to follow instructions below can cause a rupture or explosion and could cause serious or fatal personal injury and/or property damage.

- Do not adjust or add pressure if there has been a loss of air.
 - Do not adjust the pre-charge pressure if there is visible exterior corrosion.
 - Do not adjust the pre-charge pressure if there has been a reduction of the pump cycle time or the pre-charge pressure compared to its initial setting. A reduction in pump cycle time can result from loss of tank corrosion and any re-pressurization or additional pressure could result in rupture or explosion.
 - Pressure tank pressure is factory set but will have to be checked regularly (at least monthly). Use an air pressure (tire) gauge. Before checking air pressure on the pressure tank, purge all water out of the tank by turning the pump on and pumping all water out of the pressure tank.
1. Our transfer pump water systems use a water pressure tank and water pump with these two pressure operation ranges:
Cut in (start pumping): 20 PSI
Cut out (stop pumping): 30 PSI (EC1-300A)
Cut out (stop pumping): 40-45 PSI (CLP, REC2-20)
 2. Typical factory set air pressure on bladder-type residential water pressure tanks are shipped from the factory with a standard pre-charge of:
18 psig for models WX-101 and WX-102
18 psig for models WX-103 and WX-203
18 psig for models WX-205 and WX-350
 3. Set the well tank air pressure to 2 PSI below the pump pressure switch cut-in pressure. This is usually 18 PSI.

MAINTENANCE INSTRUCTIONS

Hot Weather

The Rec 2-20 may encounter minor problems, such as a slight increase in odor, when operating in extremely hot temperatures in excess of 100° F.

Environmental

To reduce deterioration of equipment it is recommended that the Rec 2-20 Water Treatment System be protected from environmental elements such as rain, snow, hail, direct sunlight, as well as freezing temperatures.

MAINTENANCE INSTRUCTIONS

Daily and weekly maintenance is important for your system to function consistently and properly. Maintenance frequency depends on many factors, such as usage, volume of sludge, etc. On-site personnel should be trained and be aware of the daily and weekly maintenance that is required to meet these performance factors. We recommend the following:

Daily Schedule:

(Performed by customer personnel)

1. Become familiar with the control panel and make sure that the electrical switch is in the ON position. This will allow your system to operate automatically.
2. While operating the system, observe and repair any water leaks.

Weekly Maintenance Schedule:

(Performed by customer personnel)

1. Check pressure gauge inside of Rec2-20 to ensure it is operating between desired pressures of 20 and 40 psi.
2. Check storage tank water levels to ensure Rec2-20 is maintaining the desired quality of water.
3. Check all three pumps inside of Rec2-20 for any function abnormalities, ie: noise changes, increased vibrating, or rattling.

REC2-20 COMPONENT IDENTIFICATION

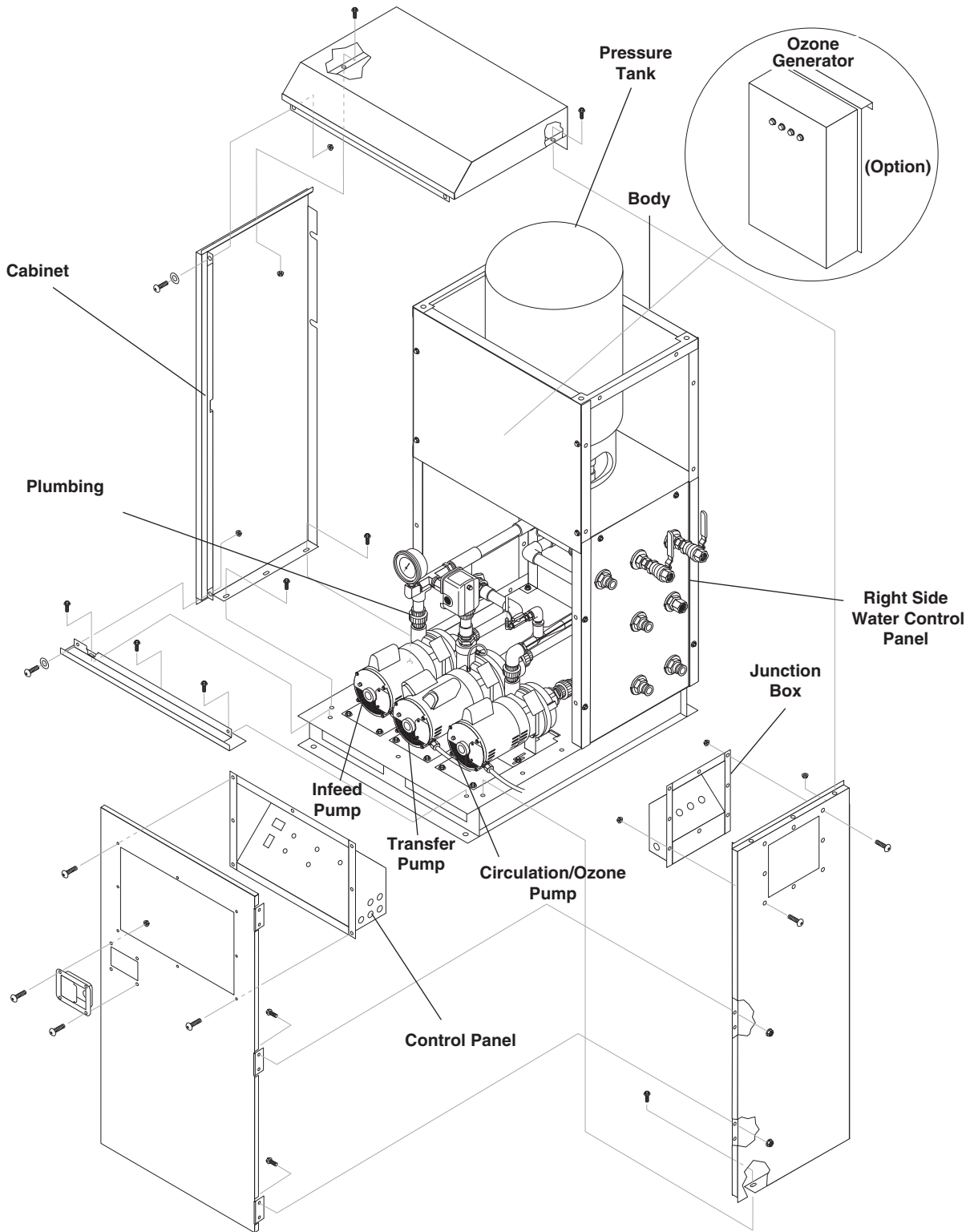

89174360-8

PIPING CONNECTION DIAGRAM

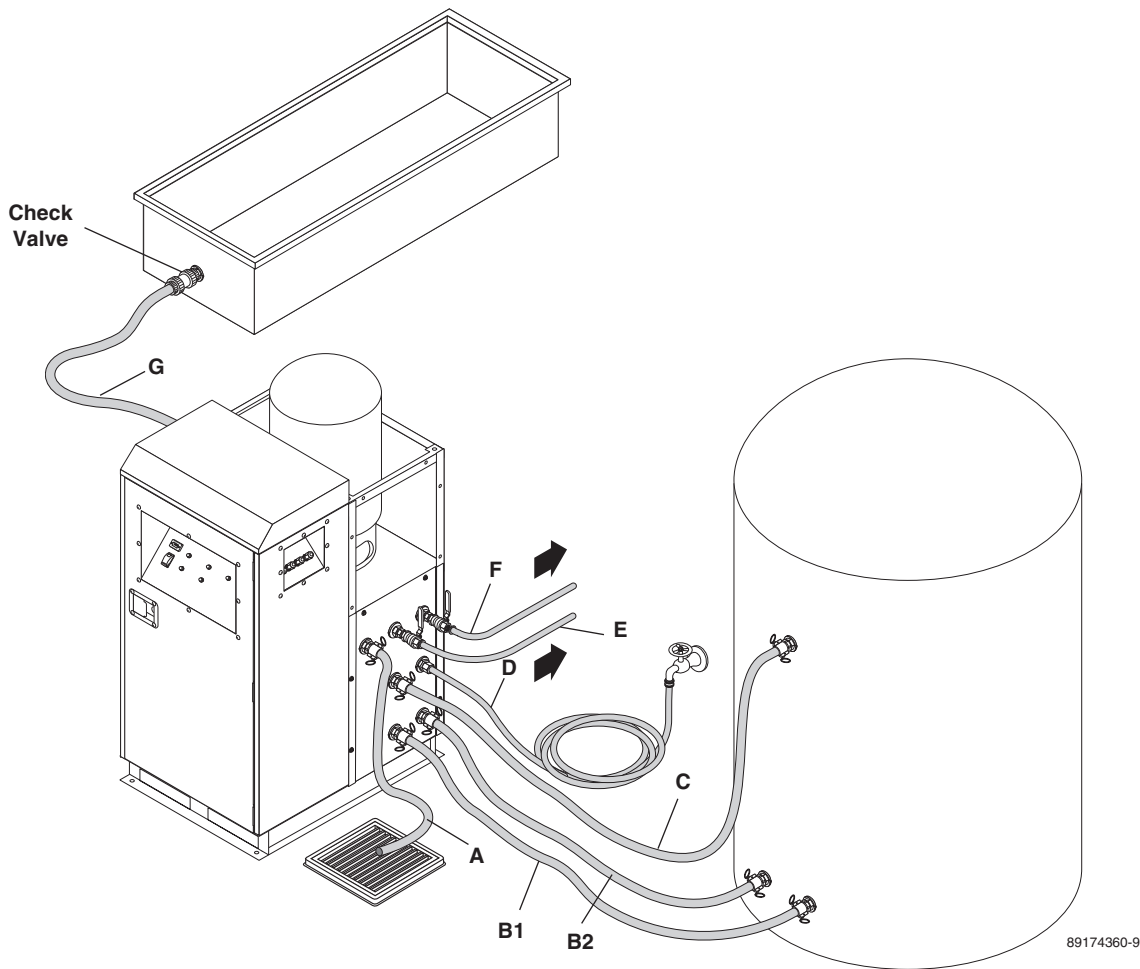

PIPING CONNECTION TABLE

CONNECTION	SIZE	EXTERIOR CONNECTION TYPE	DESCRIPTION	INSTALLATION RECOMMENDATIONS
A	1"	CAMLOCK, 1" HOSE BARB (8.711-811.0)	DRAIN OUTLET	No valves should be placed between outlet and drain in case water overflow needs to be purged.
B1, B2	1"	CAMLOCK, 1" HOSE BARB (8.711-811.0)	INLETS FROM STORAGE TANK	Valves should be installed inline for ease of maintenance.
C	1"	CAMLOCK, 1" HOSE BARB (8.711-811.0)	STORAGE TANK OUTLET	
D	1"	3/4" GARDEN HOSE, MALE	FRESH WATER INLET	Inlet should be directly connected to fresh water and should always be left open.
E	1"	3/4" GARDEN HOSE, FEMALE	PRESSURE WASHER OUTLET	
F	1"	3/4" GARDEN HOSE, FEMALE	AUXILIARY FRESH WATER OUTLET	Outlet is directly connected to fresh water inlet and can be used as normal wall faucet.
G	1"	CAMLOCK, 1" HOSE BARB (8.711-811.0)	INFEEED SOURCE INLET	Line from infeed /sump tank needs check valve (provided) installed near tank outlet, with flow directed away from tank.

FLOAT CONNECTION DIAGRAM

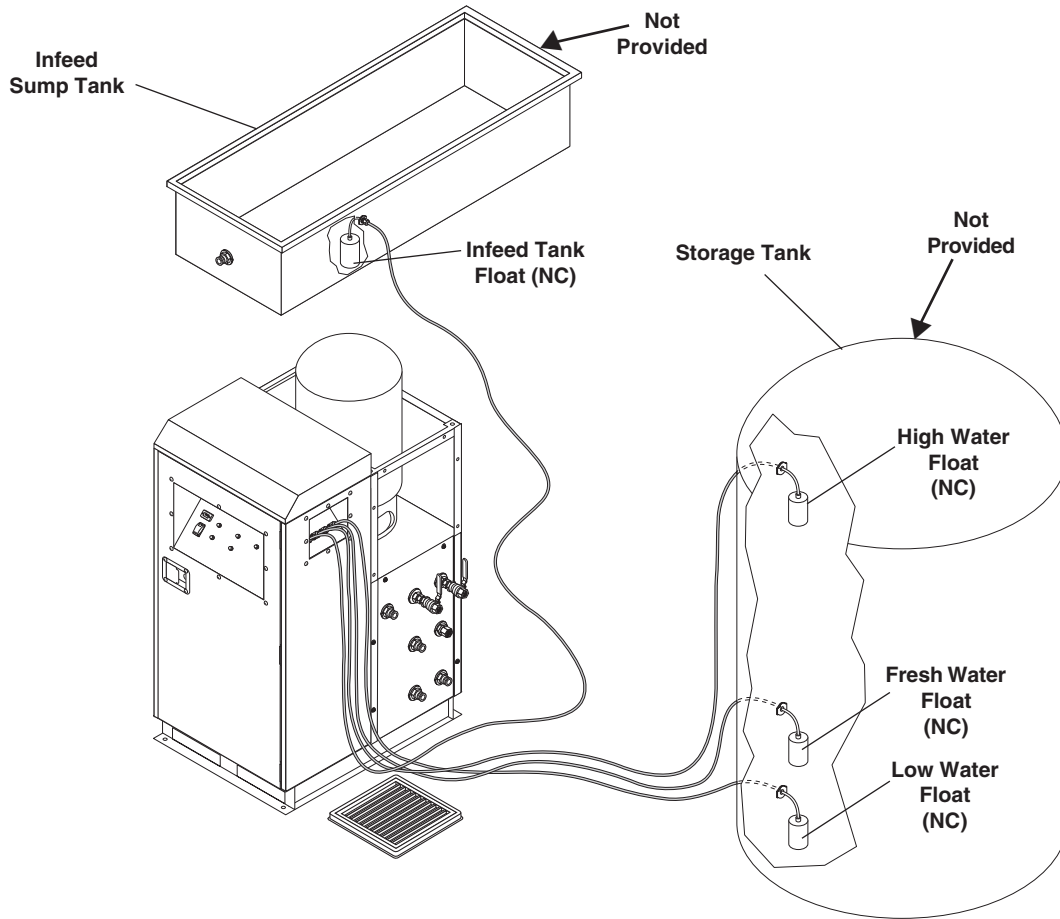

89174360-10

FLOAT CONNECTION TABLE

FLOAT NAME	FLOAT FUNCTION	PLACEMENT NOTES
INFEED TANK FLOAT (NOT PROVIDED) (WaterMaze # 8.716-143.0)	Signals REC2-20 module to remove water from infeed source.	Float needs to close (Lowered position) before infeed/sump tank water level drops below suction port to prevent dry running and loss of pump priming. For convenience, a "Delay Off" function for the infeed pump is available. To fine tune pumps turn off timing. See digital timer instructions to set function.
HIGH WATER FLOAT	Signals REC2-20 module to purge excess water from storage tank.	Float needs to open (raised position) before water reaches overflowing levels.
FRESH WATER FILL LEVEL FLOAT	Sets the water level that REC2-20 will fill to with fresh water.	Float will maintain a water level of at least its open or raised position.
LOW WATER FLOAT	Shuts off pumps if water level if too low for protection against dry running.	Float needs to close (lowered position) before storage tank level drops below suction ports to prevent dry running and loss of pump priming.

*All floats are to be wired into REC2-20 module junction box, as indicated by junction box label. See included junction box wiring diagram, page 34, for float placement on terminal block. Junction box terminal block can be reached by removing four bolts and blue cover plate seen in the exploded view of junction box.

DIGITAL TIMER INSTRUCTIONS

PARAMETER SETTINGS

The following are instructions on how to set the parameters on the digital timer, located in the electrical box, in Programming Mode. To define these settings please follow the steps below.

Setting the Clock:

In order for the system to function properly you must accurately set the correct time-of-day and date.

1. Press the **ESC** key located next to the display window and under the arrow key pad (see figure below). Pressing the **ESC** key will access the Parameter Assignment Menu.

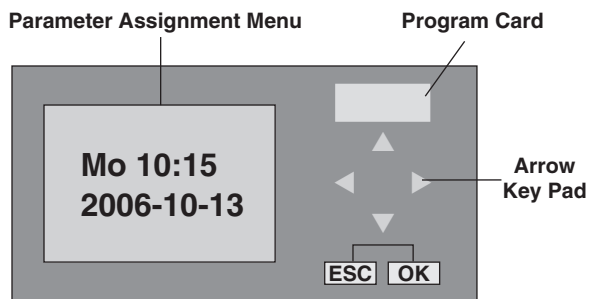

2. Using the up/down arrow keys ▲ or ▼, move the (>) cursor to 'Set' and press **OK** to accept.

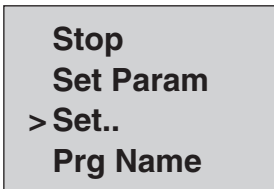

3. Move the (>) cursor to 'Clock' and press **OK** to accept.

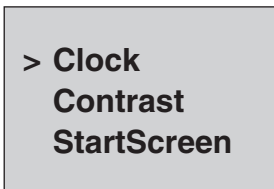

4. Move the (>) cursor to 'Set Clock' and press **OK** to accept 'Set Clock'.

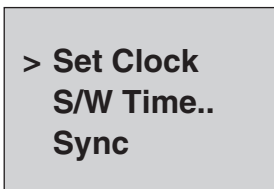

Note: When setting time on clock, use only military time.

The cursor is now positioned on the weekday and shows the following on the display window (see figure below).

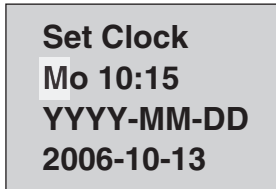

5. Select the day of the week by using the up/down arrow keys ▲ or ▼.
6. Move the cursor to the next position by using the left/right arrow keys ◀ or ▶.
7. To change the value use the up/down arrow keys ▲ or ▼.
8. To set the correct time-of-day and date, repeat steps 6 and 7.
9. To accept your entries press **OK**.
10. To go back to the previous menu at anytime press **ESC**.

DIGITAL TIMER INSTRUCTIONS

Setting water circulation times and ozone treatment for machines with option:

1. Press the **ESC** key located next to the display window and under the arrow key pad (see figure below). Pressing the **ESC** key will access the Parameter Assignment Menu.

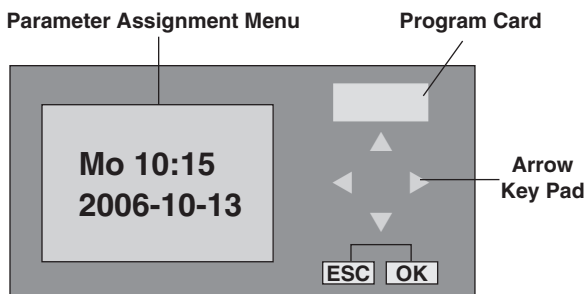

2. Using the up/down arrow key **▲** or **▼**, move the (>) cursor to 'Set Param' and press **OK** to confirm. The display window shows the first parameter shown (see figure below). You can change the value of the parameter in the same way as you did in programming mode:

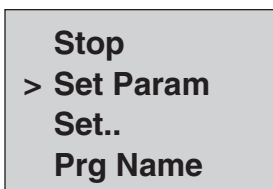

3. The display window shows **CIRC/OZ1, CIRC/OZ2, CIRC/OZ3, and DELAY OFF**. CIRC/OZ 1 comes factory set at 2 and 4, so water will circulate or be treated with Ozone, between 2 and 4 am Monday thru Friday. There are additional settings available, CIRC/OZ 2 and CIRC/OZ 3, if more circulating times are desired. Use the up/down arrow keys **▲** or **▼** to toggle through the function screen you would like to edit.
4. Press **OK** to edit the parameter that shows in the display window.

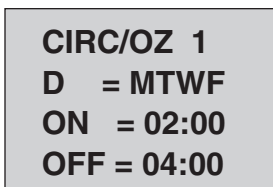

5. Using the left/right arrow key **◀** or **▶**, move the cursor to the desired field and use the up/down arrow key to change this value. Press **OK** to accept the value.
6. The DELAY OFF function can be used to delay the shut off of the Infeed pump in cases when additional water removal is required after the infeed float is lowered. This function should be used with caution to prevent the pump from over drawing the infeed source and dry running. The DELAY OFF function is factory set at 0 seconds.

OPERATION AND MAINTENANCE

CENTRIFUGAL PUMP

Your centrifugal pumps have been quality-built and engineered to give you efficient, dependable service. They are equipped with union connectors to make installation and future service easier.

The advanced design uses a single speed motor which reduces operation and maintenance to simple, common-sense procedures.

PUMP OPERATION

(Infeed Transfer and Ozone Pumps)

! WARNING



RISK OF ELECTRIC SHOCK: USE CAUTION WHEN HANDLING.

WARNING: Do not touch pumps, pump motors, water or discharge piping when the pumps are connected to electrical power. Do not handle a pump or pump motor with wet hands or when standing on a wet or damp surface or in water. Never touch a pump or discharge piping when a unit is operating or fails

to operate. Always disconnect the pump cord (power) before handling.

1. The shaft seal depends on water for lubrication. Do not operate the pump unless there is water. Dry running (pump not pumping water) will cause seal damage and eventual pump failure.
2. The motor is equipped with an automatic reset thermal protector. This means if the temperature in the motor should rise unduly, the switch will cut off all power before damage can be done to the motor. When the motor has cooled sufficiently, the switch will reset automatically and restart the motor. If the protector trips repeatedly (cycling on protector) the pump should be removed and checked for the cause of the difficulty. Low voltage, long extension cords, clogged impeller, very low head or lift, etc., could cause cycling. Cycling of the protector will cause eventual motor burnout.

PUMP MAINTENANCE

! WARNING



RISK OF ELECTRIC SHOCK: USE CAUTION WHEN HANDLING.

WARNING: Before attempting to service, disconnect power from unit. Do not handle the pump with wet hands or when standing on a wet or damp surface or in water. Failure to follow precautions can result in personal injury and /or property damage.

NOTE: Only qualified electricians or servicemen should attempt to repair this unit. Improper repair and/or assembly can cause an electrical shock hazard.

1. Bearings in this unit are pre-lubricated. No additional lubrication is necessary.
2. Cleaning - Occasionally clean the transfer pit and pump if dirt or foreign matter accumulate. Small stones, gravel, sand, dirt, silt, etc. can clog and damage the pump and pump seal, eventually causing pump failure.
3. Disassembly of the motor prior to expiration of the warranty will void the warranty. It may also cause internal leakage and damage to the unit. If repairs are required, return the pump to a local service station.
4. If the motor has been disassembled or the switch chamber opened after the warranty expiration date, the O-rings and gaskets must be replaced. Care must be taken to assure that the seals, the switch cover and air tube gaskets do not leak.
5. The pump should be checked for proper operation weekly or monthly by watching the operation of the pump. If anything has changed since the pump was new, the pump should be examined, and repaired if necessary.

TROUBLESHOOTING - PUMP

PROBLEM	POSSIBLE CAUSE	SOLUTION
INFEEED PUMP DOES NOT OPERATE	Sump or pre-treatment tank has low water level	Raise level in sump or pre-treatment tank.
	Control panel pump switch is in the OFF position	Confirm that control panel pump switch is in the ON position.
TRANSFER PUMP DOES NOT OPERATE	Storage has low water level	Ensure tank is filling with fresh water and wait.
	Pressure limit has been achieved	Need water demand for pump to start.
	Control panel pump switch is in the OFF position	Confirm that control panel pump switch is in the ON position.
PUMP DOES NOT OPERATE	Program timer is not set for current time	See Digital Timer Instructions page to reset circulation times.
	Storage tank has low water level	Ensure tank is filling with fresh water and wait.

TROUBLESHOOTING - PUMP

PROBLEM	POSSIBLE CAUSE	SOLUTION
ONE OF THE PUMPS DOES NOT TURN ON	Circuit breaker shut "OFF"	Turn "ON" circuit breaker.
	Accumulation of trash on float	Clean float.
	Float obstruction/ defective float	Check float path and provide clearance.
	Defective switch	Have pump serviced by authorized service center.
	Defective motor	Have pump serviced by authorized service center.
	Low line voltage	If voltage under recommended minimum, check size of wiring from main switch on property. If OK, contact power company.
ONE OF THE PUMPS WILL NOT SHUT OFF	Float obstruction	Check float and float rod path. Provide clearance.
	Pump is air locked (Infeed pump)	Shut power off for approximately 1 minute, then restart. Repeat several times to clear air from pump.
	Defective float switch	Disconnect switch, check with ohmmeter.
ONE OF THE PUMPS RUNS BUT DOES NOT DISCHARGE LIQUID	Lift too high for pump	Check rating table. See pages 32 and 33.
	Inlet to impeller plugged	Pull pump and clean.
	Low line voltage	If voltage under recommended minimum, check size of wiring from main switch on property. If OK, contact power company.
	Clogged impeller	Remove housing, unclog.
	Faulty motor protector	Replace pump.
ONE OF THE PUMPS DOES NOT DELIVER RATED CAPACITY	Low voltage, speed too slow	Check for proper supply voltage to make certain it corresponds to nameplate voltage.
	Impeller or discharge pipe is clogged	Pull pump and clean. Check pipe for scale or corrosion.
	Impeller wear due to abrasives	Replace worn impeller.
ONE OF THE PUMPS CYCLES CONTINUALLY	Low line voltage	If voltage under recommended minimum, check size of wiring from main switch on property. If OK, contact power company.
	Worn or defective pump parts or plugged impeller	Replace worn parts or entire pump. Clean parts if required.
	Pump air locked	Turn pump "ON" and "OFF" several times. Fill hose manually with water.
TRANSFER PUMP DOES NOT STARTUP	Lack of water in tank	Add water
	Bad low water protection float in tank	Replace float
	Pump switch off	Turn on main switch
TRANSFER PUMP DOES NOT SHUT OFF	Surge tank pressure too high	Lower air pressure to 18 psi
	Pressure switch cut off, setting too high	Lower cut off pressure to 40 psi Adjust small spring - rotate counterclockwise

TROUBLESHOOTING - PUMP MOTOR

PROBLEM	POSSIBLE CAUSE	SOLUTION
MOTOR WILL NOT RUN	Disconnect switch is "OFF"	Be sure switch is on.
	Breaker is tripped	Reset breaker.
	Starting switch is defective	Replace starting switch.
	Wires at motor are loose, disconnected or wired incorrectly	Refer to wiring instructions. Check and tighten all wiring.
MOTOR RUNS HOT AND OVERLOAD KICKS OFF	Motor is wired incorrectly	Refer to wiring instructions
	Voltage is too low	Check with power company. Install heavier wiring if wire size is too small. See wiring instructions.
	Defective float switch	Disconnect switch, check with ohmmeter.
MOTOR RUNS BUT NO WATER IS DELIVERED	Pump in a new installation did not pick up prime through: a. Improper priming b. Air leaks	a. Re-prime (3 or 4 times may be needed) by stopping and starting motor several times. b. Check all connections on suction line.
	Pump has lost its prime through: a. Air leaks b. Water level below suction of pump	a. Check all connections on suction line, air volume control, jet and shaft seal. b. Lower suction line into water and re-prime.
	Check valve is stuck in closed position	Replace check valve.
	Pipes are frozen	Thaw pipes. Bury pipes below the frost line. Heat pipes below frost line. Heat pit or pump house.

TROUBLESHOOTING - WATER SOLENOID

PROBLEM	POSSIBLE CAUSE	SOLUTION
VALVE LEAKS WHEN "OFF"	Dirt or debris on diaphragm seat	Clean diaphragm seat.
	Solenoid not fully closed after manual operation	Turn solenoid clockwise to fully seated position.
	Solenoid O-ring damaged or twisted	Turn off water, inspect O-ring. Reseat if twisted, replace solenoid valve.
	Diaphragm damaged	Turn off water, remove bonnet screws and inspect diaphragm for nicks or damage NOTE: Diaphragm has one bleed hole molded into it. Replace solenoid valve.
	Dirt interfering with solenoid operation	Turn off water, remove solenoid and flush seating surface in bonnet and at bottom of solenoid with water.
	Solenoid damaged	Turn off water supply and replace solenoid.
WATER WON'T SHUT OFF	Valve in manual "ON" position	Turn solenoid clockwise to "OFF" position.
	Diaphragm bleed hole blocked	Use Manual Flush Mode. Turn water supply "OFF" and immediately back "ON" to clear blockage. If still blocked, turn off water and inspect diaphragm looking for blockage.
	Damaged solenoid	Turn off water supply and replace solenoid.
LOW OR INADEQUATE FLOW CONDITION	Gate valve not fully open	Open gate valve fully.
	Pipeline blockage	Clear pipeline.
VALVE WON'T TURN ON ELECTRICALLY	No power to solenoid	Check floats in tank
	Low voltage	Check for proper voltage to unit.
	No water pressure	Make sure water pressure is available to valve. Turn off water, without cutting wires, unscrew and swap solenoids between valves. Turn on water and test again. If problem stems from the solenoid, replace solenoid.

TROUBLESHOOTING - WATER SEALS

PROBLEM	POSSIBLE CAUSE	SOLUTION
CRACKED OR BROKEN STATIONARY SEAT (CERAMIC)	Seal ran dry and heated up. When liquid reached seal faces it was cooler, causing thermal cracks	Check to insure seal chamber is full of liquid before starting pump. On high temperature application insure proper flushing at seal faces.
CARBON WASHER SCORED AND GROOVED	Dirty system	Have system cleaned and flushed. Consider use of Tungsten Carbide or Silicon Carbide Rings.
CARBON WASHER WORN UNEVENLY	Seal improperly installed	Check installation instructions for proper assembly.
BUNA DIAPHRAGM HARD OR BRITTLE. RAPID CARBON WEAR.	Air leak on suction side of pump	Check cover gasket, hand knobs, hose, clamps, etc. Replace or tighten as necessary.
DIAPHRAGM SOFT AND STICKY; APPEARS TO BE DISSOLVING.	Bellows not compatible with material being pumped	Consult dealer for recommendation advising of pumpage and temperature.
"OPTIONAL" OZONE GENERATOR DOES NOT TURN ON DURING PROGRAMMED CIRCULATION TIME (INDICATED BY GREEN LIGHTS ON OZONE BOX INSIDE REC2-20 CABINET)	Time or <u>Ozone</u> program is not set correctly	Consult manual for proper setting on adding additional ozone/recirculation time.
	<u>Ozone</u> generator power switch is not on	Turn on ozone power switch on cabinet.
	Green lights on ozone generator start off green then go dim, bright	Proper operation-If lights stay bright green, then problem with ozone bulb or ballast - refer to manual.

EXPLODED VIEW – BODY

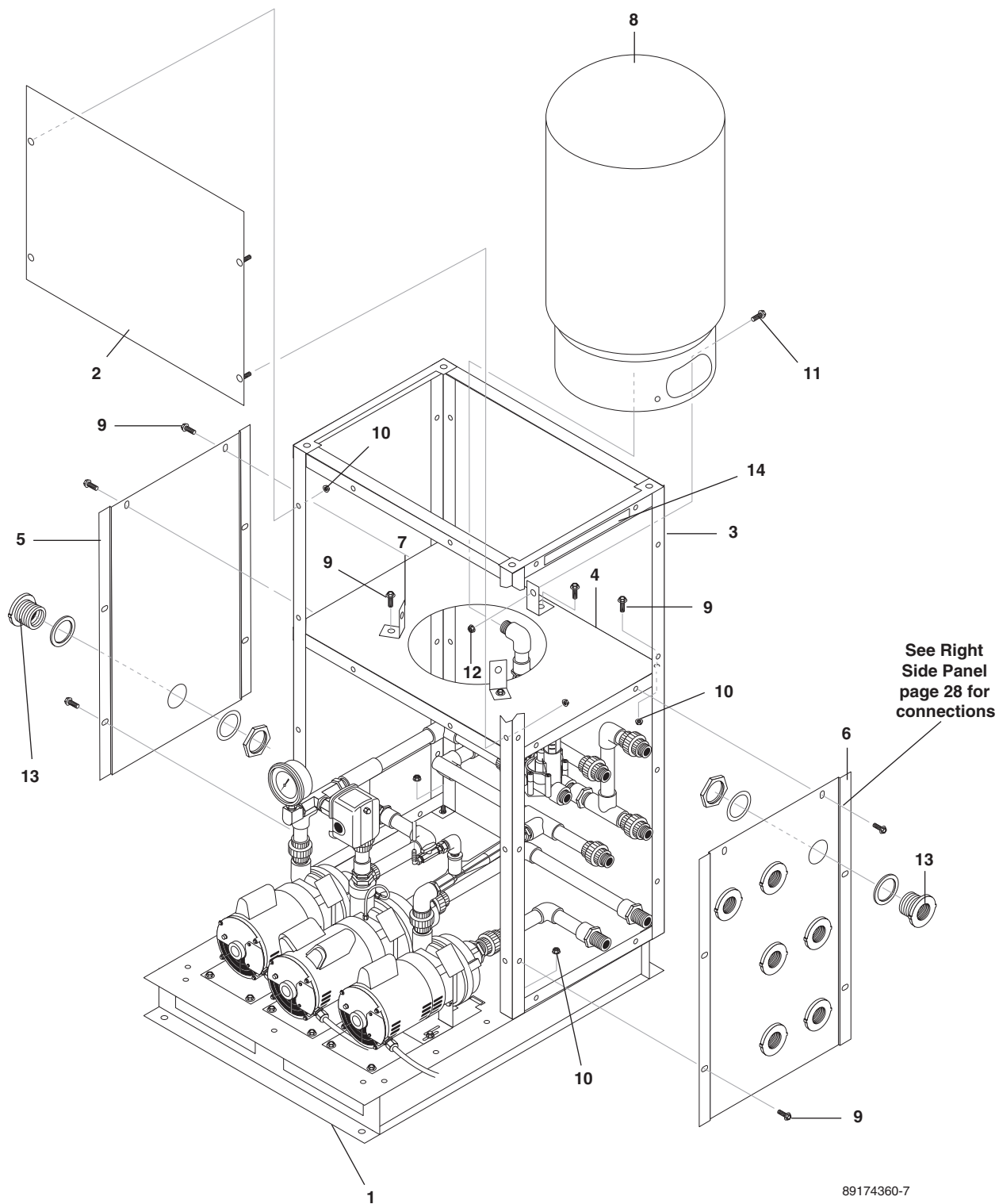

89174360-7

EXPLODED VIEW PARTS LIST– BODY

ITEM	PART NO.	DESCRIPTION	QTY	ITEM	PART NO.	DESCRIPTION	QTY
1	8.917-450.0	WLMT, Base Recycle	1	10	9.802-778.0	Nut, 5/16" Whiz Loc Flange	8
2	8.917-452.0	WLMT, Panel, Back, Recycle	1	11	9.802-754.0	Screw, 1/4" x 1/2" NC, Whiz Loc Flange	3
3	8.917-457.0	WLMT, Tank Stand Frame, Recycle	1	12	9.802-775.0	Nut, 1/4" Flange, ZN	3
4	8.917-435.0	WLMT, Top, Tank Stand, Recycle	1	13	8.706-484.0	Bulkhead, 1" Polypro	8
5	8.917-438.0	Panel, Left, Tank Stand, Recycle	1	14	9.800-348.0	Label, Do not stand on Frame	2
6	8.917-444.0	Panel, Right, Tank Stand, Recycle	1	15	9.800-016.0	▲ Label, Disconnect Power supply	1
7	8.917-449.0	Bracket, Tank Base, Recycle	3	16	9.800-347.0	▲ Label, Warnings	1
8	8.719-178.0	Tank, 20 Gal Prepressurizd, Blue, WTRSTX-202	1			▲ Not Shown	
9	9.803-277.0	Screw, 5/16" x 1/2", Whiz Loc Flange	19				

CABINET EXPLODED VIEW

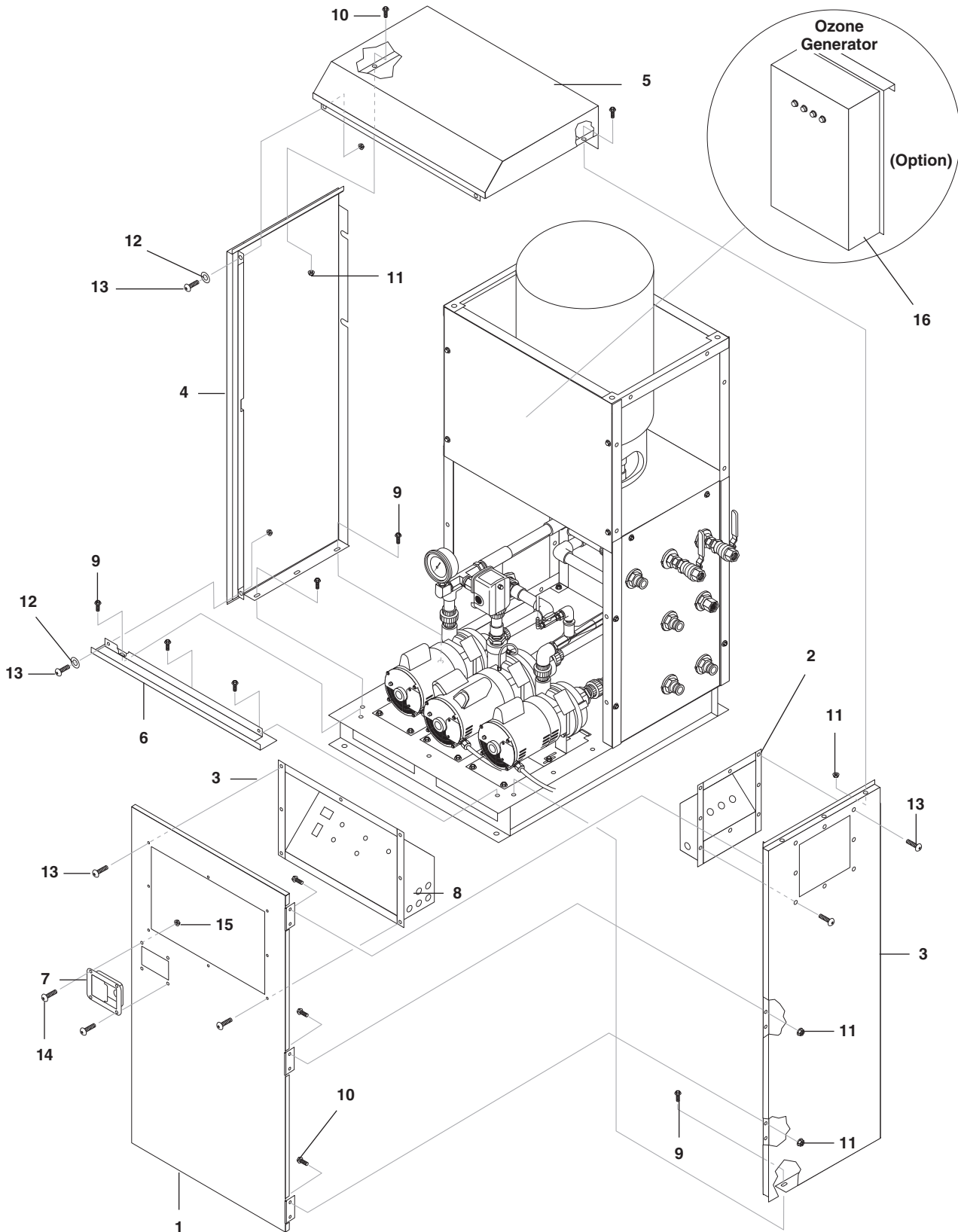

89174360-12

CABINET EXPLODED VIEW PARTS LIST

ITEM	PART NO.	DESCRIPTION	QTY
1	8.917-456.0	Wlmt, Door, Recycle	1
2	8.917-536.0	Wlmt, Junction Box, Recycle	1
3	8.917-431.0	Panel, Right Side, Cabinet, Recycle	1
4	8.917-432.0	Panel, Left, Cabinet, Recycle	1
5	8.917-428.0	Top, Cabinet, Recycle	1
6	8.917-430.0	Base, Cabinet, Recycle	1
7	8.719-087.0	Latch, Paddle Handle w/Key	1
8	8.917-435.0	Wlmt, Control Panel, Rec2-20	1
9	9.803-277.0	Screw, 5/16" x 1/2", Whiz Loc Flange	9
10	9.802-754.0	Screw, 1/4" x 1/2" NC, Whiz Loc Flange	12
11	9.802-775.0	Nut, 1/4" Flange, ZN	12
12	8.718-980.0	Washer, 5/16", Flat, SAE	4
13	9.803-541.0	Screw, 5/16-18 x 1/2 CS SOC BH NC ZN	20
14	8.718-753.0	Screw, 1/4"-20 x 3/4" PHIL PH SS M/S	4
15	8.718-882.0	Nut, 1/4-20 NC KEPS SS	4
16	8.905-717.0	Ozone Generator, Series 400 (Option only)	1

EXPLODED VIEW ELECTRICAL BOX

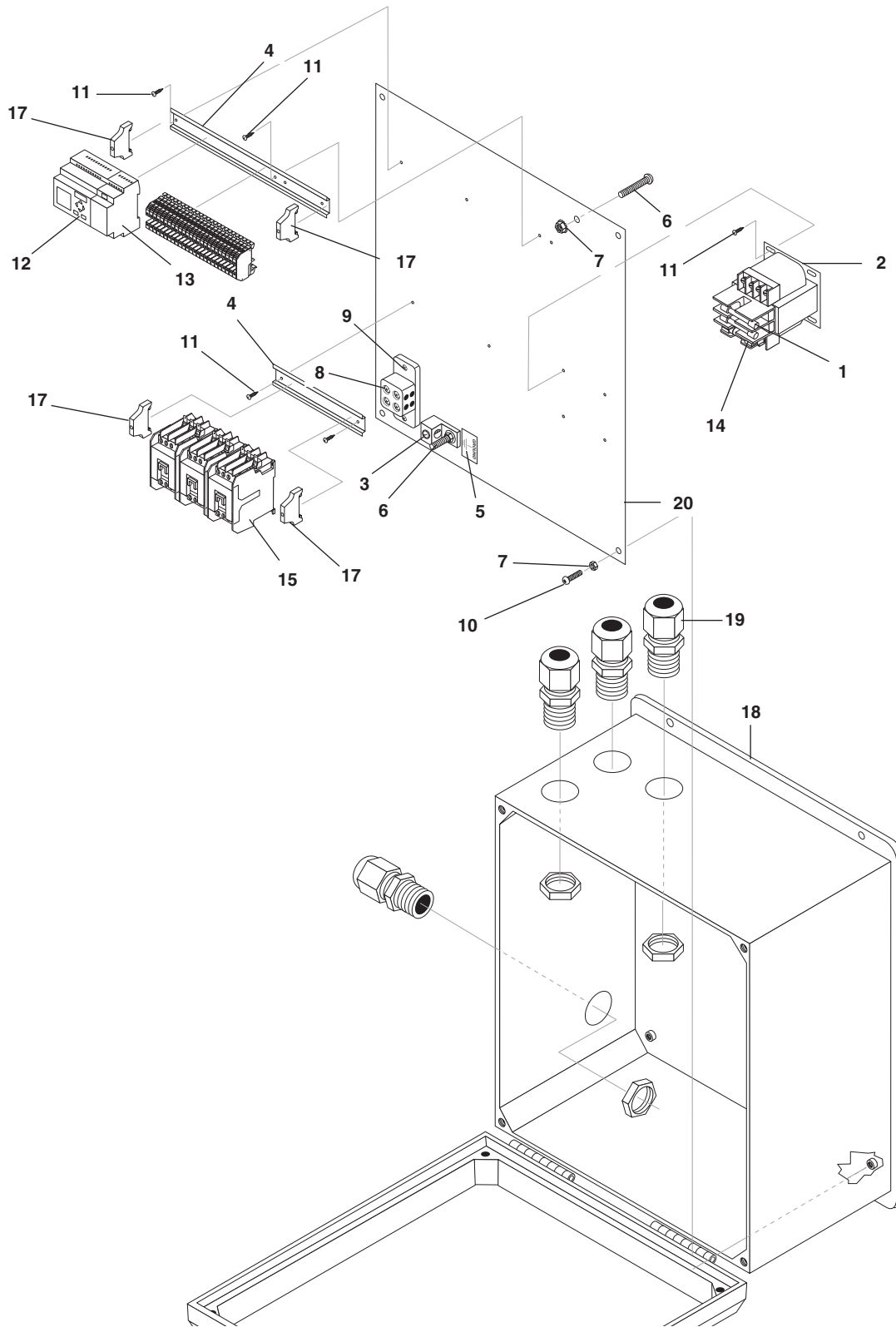

89174360-

ELECTRICAL BOX EXPLODED VIEW PARTS LIST

ITEM	PART NO.	DESCRIPTION	QTY
1	8.716-180.0	Fuse, KTK-R4 600V Midget Fuse (4 AMP)	2
2	8.716-883.0	Transformer, 208/230/460V- 24/115V, .050 KVA	1
3	8.716-460.0	Terminal, Grounding Lug, LAMA6-14Q	1
4	9.802-457.0	DIN Rail, 35 MM	Cut to Fit
5	9.800-040.0	Label, Ground Symbol	2
6	9.802-762.0	Screw, 10/32" x 1-1/4" RH, SL, BLK	2
7	9.802-695.0	Nut, 10/32" Keps	12
8	8.714-164.0	Terminal Block- 2 Position (Surface) BL-BL	1
9	8.718-937.0	Screw, #8 x 3/4", Phillips, Zinc PLTD, HEX, T	2
10	9.802-759.0	Screw, 10/32" x 1/2" BHSOC BLK	5
11	8.718-936.0	Screw, #8 x 1/2" Phillips, Zinc PLAT TEK	9
12	8.917-842.0	PLC, Programmed REC2-20	1
13	8.723-168.0	Expansion Module Siemens 6ED 10551HB000BA0	1
14	8.716-199.0	Fuse, FNM-6.25	1
15	8.724-267.0	Contractor, DP C25DNY151TL, 15 AMP	3
16	8.749-976.0	Terminal Block, Feed- through, Phoenix	25
17	9.804-595.0	End Bracket, Entrelec, 103-002-26	4
18	8.716-281.0	Box, Plastic, 14" x 16" x 6.75" W/Hinged Lid	1
19	9.802-518.0	Strain Relief, LT, STR, 3/4 NPT .49-.71D	4
20	8.917-612.0	Electrical Standoff, Recycle	1

CONTROL PANEL EXPLODED VIEW

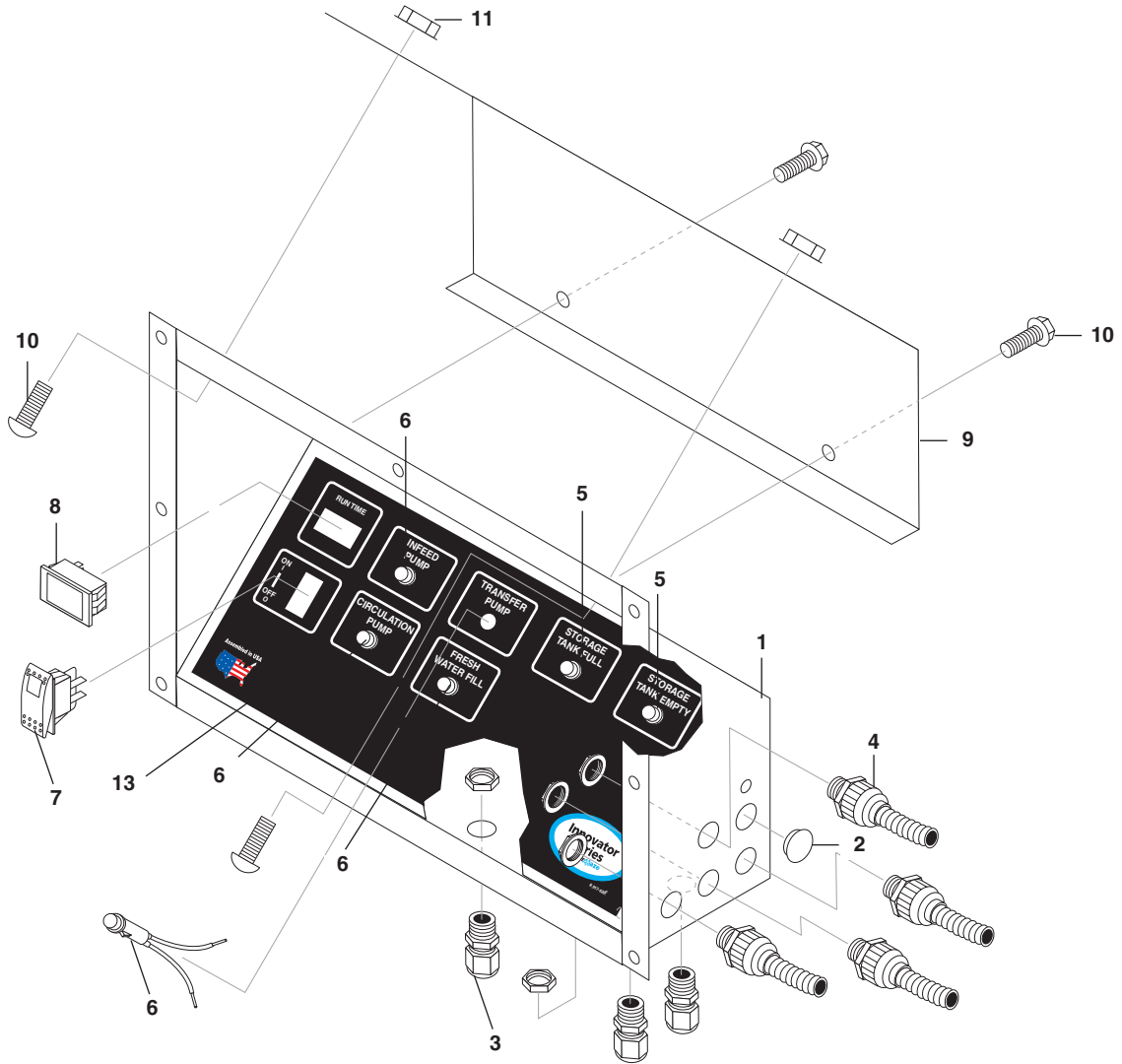

89174360-2

CONTROL PANEL EXPLODED VIEW PARTS LIST

ITEM	PART NO.	DESCRIPTION	QTY	ITEM	PART NO.	DESCRIPTION	QTY
1	8.917-455.0	Wlmt, Control Panel, Rec2-20	1	10	9.803-277.0	Screw, 5/16" x 1/2", Whiz Loc Flange	6
2	8.706-745.0	Plug, Plastic 0.812	1	11	9.802-778.0	Nut, 5/16" Whiz Loc Flange	4
3	9.802-518.0	Strain Relief 3/4"	3	12	9.802-514.0	Strain Relief 1/2" (Only On Machines With Ozone Generator, In Place Of Plug)	1
4	8.716-547.0	Strain Relief 1/2", Conduit	4	13	8.917-620.0	Label, Recycle Control Panel	1
5	9.803-651.0	Lamp Indicator, Red 28V	2	14	8.917-621.0	▲ Label, Recycle Descriptive Label	1
6	9.803-650.0	Lamp Indicator, Blue 28V	4			▲ Not Shown	
7	8.716-037.0	Switch, Rocker 24V	1				
8	9.802-283.0	Hour Meter	1				
9	8.917-445.0	Cover, Control, Rec2-20	1				

JUNCTION BOX EXPLODED VIEW

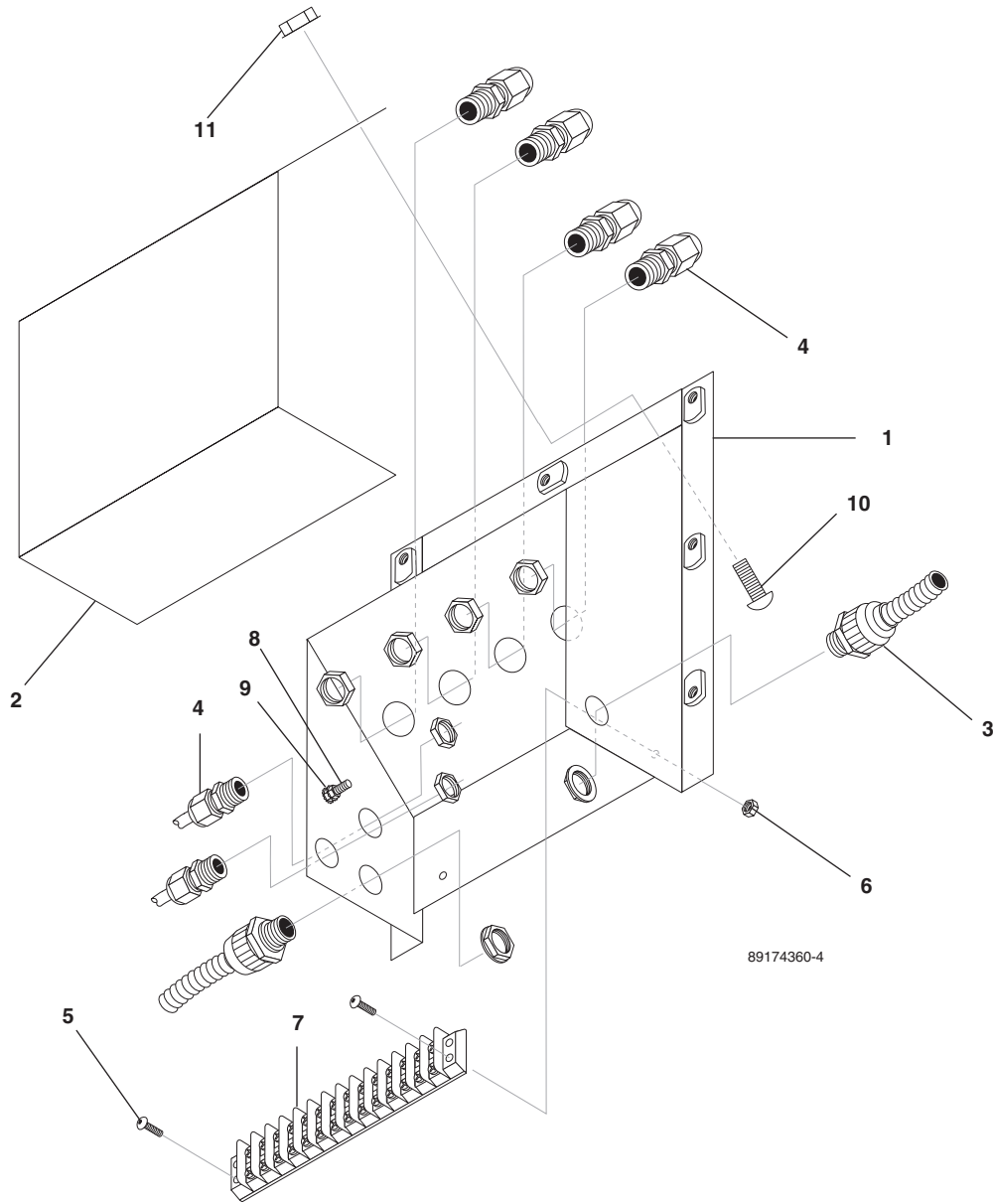

JUNCTION BOX EXPLODED VIEW PARTS LIST

ITEM	PART NO.	DESCRIPTION	QTY	ITEM	PART NO.	DESCRIPTION	QTY
1	8.917-536.0	Wlmt, Junction Box, Recycle	1	8	9.802-759.0	Screw, 10/32" x 1/2" BHSOC BLK	1
2	8.917-540.0	Cover, Junction Box, Recycle	1	9	9.802-695.0	Nut, 10/32" KEPS	2
3	8.716-547.0	Connector, 1/2" L/T, Straight, Black	2	10	9.803-277.0	Screw, 5/6" x 1/2", Whiz Loc Flange	4
4	9.802-514.0	Strain Relief, L/T, Str, 1/2 NPT, .23-.45D	6	11	9.802-778.0	Nut, 5/16" Whiz Loc Flange	4
5	9.802-749.0	Screw, 8/32" x 3/4" BHSOC	2	12	8.917-622.0	▲ Label, Recycle Junction Box1	
6	9.802-785.0	Nut, 8/32" KEPS	2			▲ Not Shown	
7	9.802-493.0	Block, Terminal, 16 Pole	1				

RIGHT SIDE WATER CONTROL PANEL EXPLODED VIEW

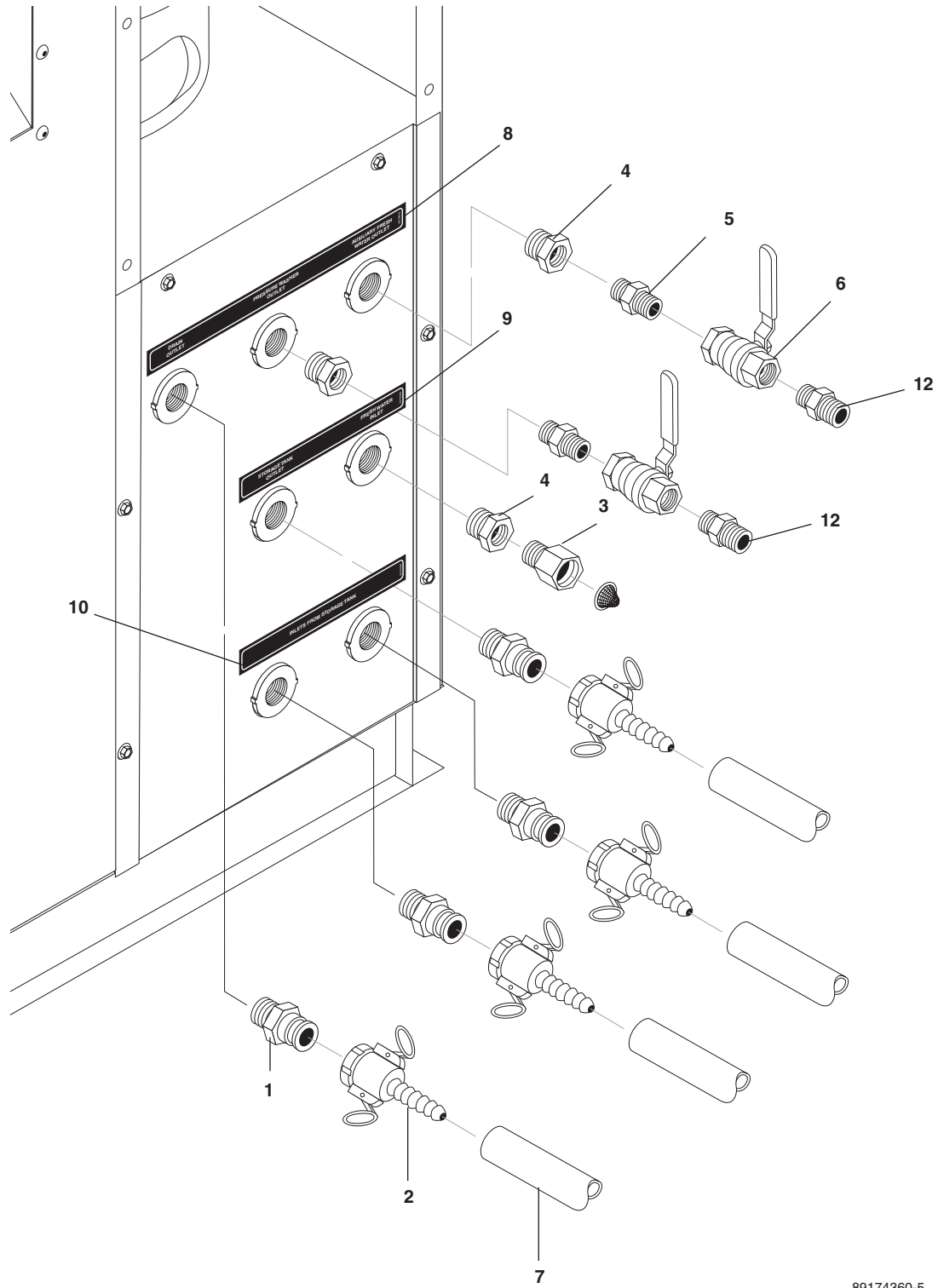

89174360-5

RIGHT SIDE PANEL EXPLODED VIEW PARTS LIST

ITEM	PART NO.	DESCRIPTION	QTY
1	8.706-707.0	Adapter, 1" Male x 1" Male Thrd. Camlock	5
2	8.706-709.0	Coupler, 1" FEM x 1" Hose Barb Camlock	5
3	9.802-146.0	Swivel, 1/2" MP x 3/4" GHF w/Strainer	1
4	8.706-926.0	Bushing, 1" x 1/2" Pipe, Brass	3
5	8.706-790.0	Nipple, 1/2" Close	2
6	8.707.211.0	Valve, 1/2" 8201 Brass Ball 400 PSI	2
7	8.711-811.0	Hose, 1" Gray Spiralite, per foot Not Provided	
8	8.917-624.0	Label, Recycle Outlet To Drain	1
9	8.917-625.0	Label, Recycle Outlet To Storage	1
10	8.917-626.0	Label, Recycle Inlets From Storage	1
11	8.917-627.0	▲ Label, Recycle Infeed Source Inlet	1
12	8.706-968.0	Nipple, 1/2" x 3/4" GH	2

▲ Not Shown

PLUMBING EXPLODED VIEW

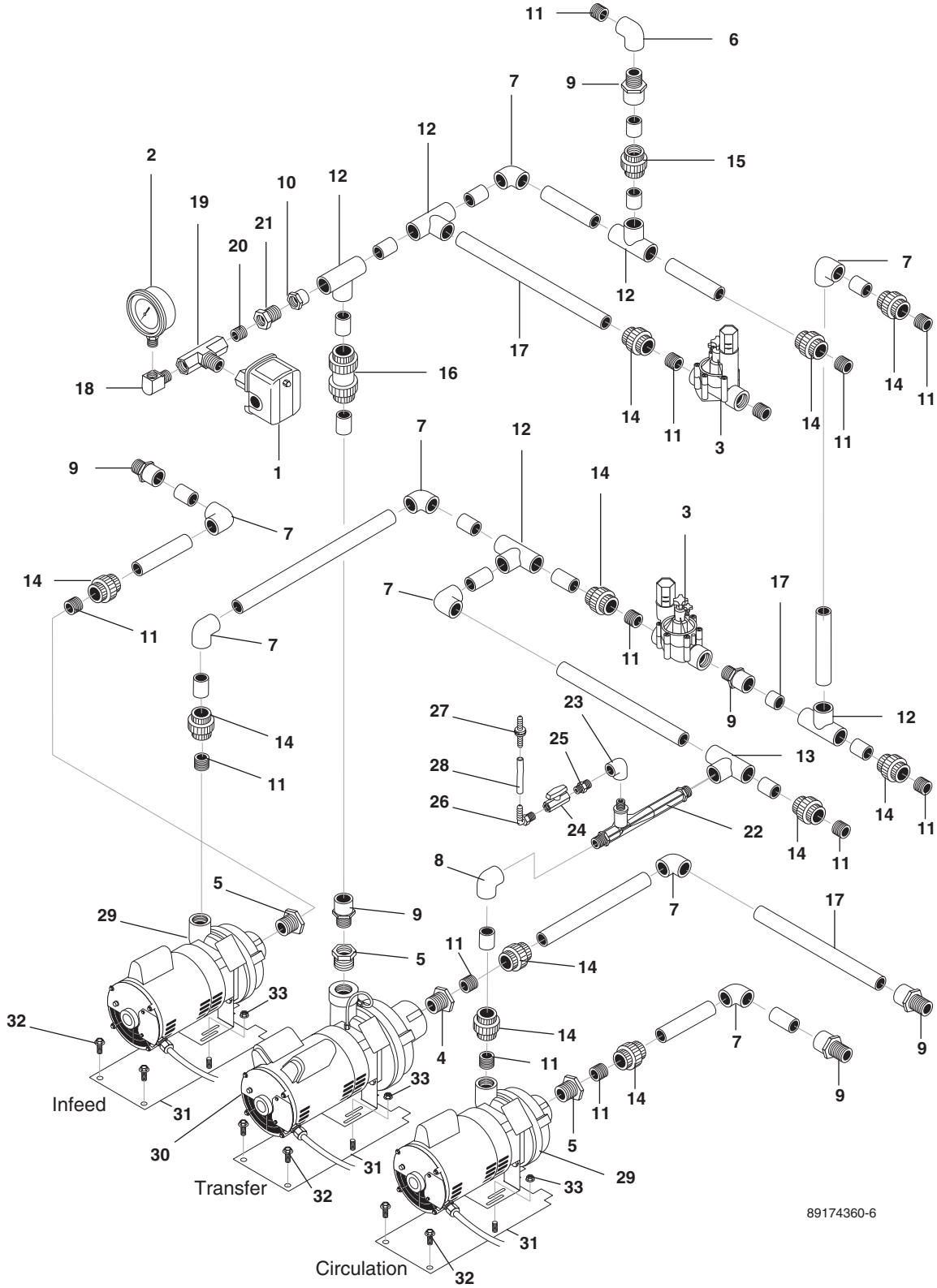

89174360-6

PLUMBING PARTS LIST

ITEM	PART NO.	DESCRIPTION	QTY
1	8.716-154.0	Switch, Pres SQ D, N/C Use W/2-10893, 2-1072	1
2	8.712-154.0	Gauge, Pressure 0-100 1/4" Bottom PG1-	1
3	8.716-697.0	Solenoid, Water Maze, PVC 24V P/N 100DVF	2
4	8.706-404.0	Bushing, 1 1/2" x 1" MT x FT, PVC 80	1
5	8.706-405.0	Bushing, 1 1/4" x 1" MT x FT, PVC 80	3
6	8.706-376.0	Elbow, 1" FIPT x FIPT, PVC 80	1
7	8.706-373.0	Elbow, 1" S x S, PVC 80, 90°	8
8	8.706-378.0	Elbow, 1" SLIP x FIPT, PVC 80, 90°	1
9	8.706-409.0	Adapter, 1" MT x SLIP, PVC 80	6
10	8.706-447.0	Adapter, 1" , 3/4" S x FIPT, PVC 80	1
11	8.706-439.0	Nipple, 1", PVC, Close	13
12	8.706-430.0	Tee, 1" S x S, PVC 80	5
13	8.706-432.0	Tee, 1" FT x SLIP x SLIP, PVC 80	1
14	8.706-471.0	Union, 1" SLIP x FMLE THRED, PVC 80 SPEA	11
15	8.706-597.0	Union, 1" S x S, PVC 80 "SPEARS"	1
16	8.707-300.0	Valve, 1" PVC Ball Check	1
17	8.706-366.0	Pipe, 1", PVC 80, /FT	Cut to fit
18	8.706-827.0	Elbow, 1/4" Street	1
19	8.706-854.0	Tee, 1/4" Branch Male	1
20	8.706-777.0	Nipple, 1/4", Close	1
21	8.706-923.0	Bushing, 3/4" x 1/4" Pipe	1
22	8.709-431.0	Injector	1
23	8.706-370.0	Elbow, 1/2" FIPT x FIPT	1
24	8.706-587.0	Nipple, 1/2" x 1/2"	1
25	8.707-321.0	Valve, 1/4"	1
26	8.706-588.0	Connector, 3/8" x 1/4" Male Elbow	1
27	8.707-355.0	Check Valve	1
28	8.711-733.0	Tubing, 3/8" Vinyl	3 in
29	8.715-393.0	Pump, 3/4 HP 1 PH	2
30	8.715-394.0	Pump, 1.5 HP 1 PH	1
31	8.917-454.0	WLMT, Pump Base	3
32	9.802-277.0	Screw, 5/16" x 1/2" Whiz Loc Flange	6
33	9.802-778.0	Nut, 5/16" Whiz Loc Flange	6

INFEED & CIRCULATION PUMP EXPLODED VIEW

#8.715-393.0 3/4 HP 1PH

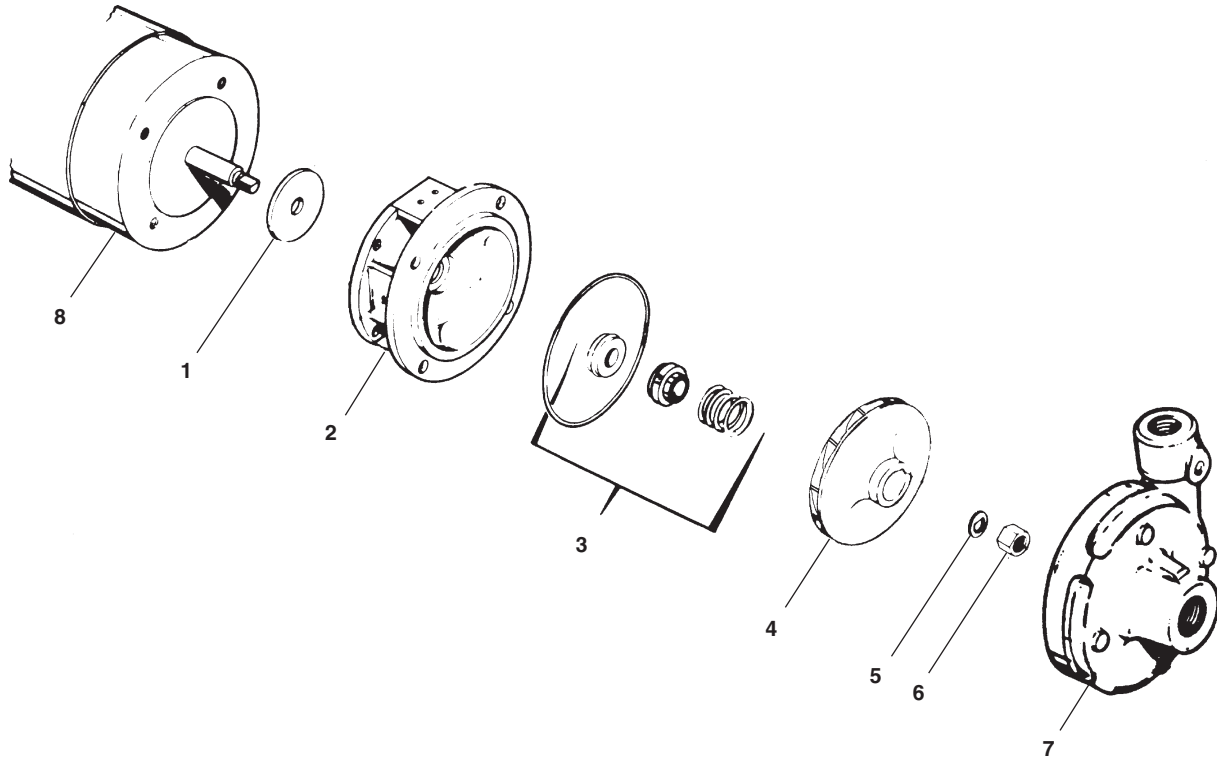

INFEED & CIRCULATION PUMP EXPLODED VIEW PARTS LIST

ITEM	PART NO.	DESCRIPTION	QTY
1	8.718-520.0	Flinger	1
2		Adapter	1
3	8.718-524.0	Seal	1
4		4.5" Impeller	1
5		Washer	1
6		Nut	1
7		Case	1
8		Motor, 3/4 HP 230V 1 PH	1

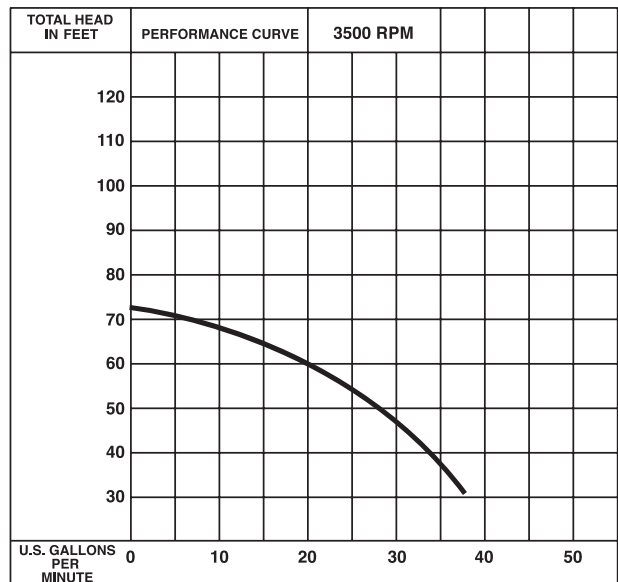

BRAND	MODEL NO.	SIZE		AMPS	VOLTS	PHASE	MAXGPM, PSI
		INLET	OUTLET				
SCOT	12	1-1/4"	1"	5.5	230	1	See Chart Above

TRANSFER PUMP EXPLODED VIEW PARTS LIST

#8.715-394.0 • 1.5 HP • 115/230V • 1PH

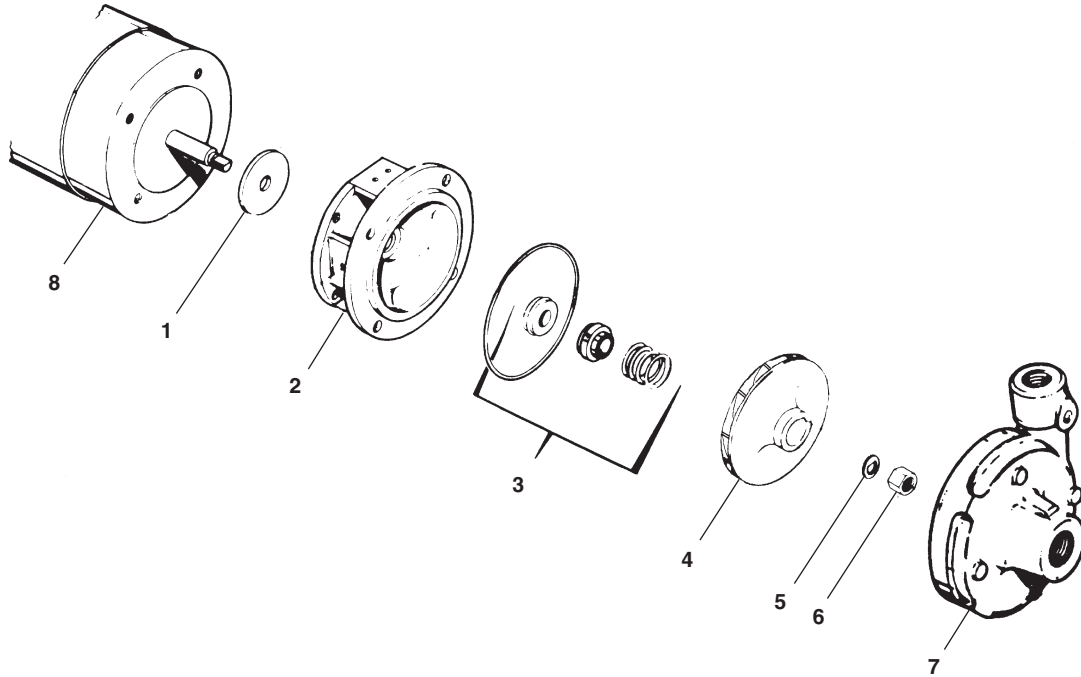

ITEM	PART NO.	DESCRIPTION	QTY
1	8.718-520.0	Washer	1
2		Base	1
3		Seal	1
4	8.718-532.0	5.13 Impeller,	1
5		Washer	1
6		Nut	1
7	8.718-529.0	Head	1
8		Motor, 1-1/2 HP 115/230 1 PH	1

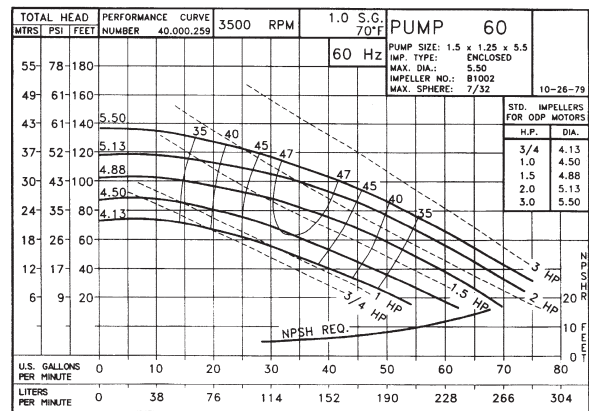

MODEL NO.	SIZE		AMPS	VOLTS	PHASE	MAXGPM, PSI
	INLET	OUTLET				
60	1-1/2"	1-1/4"	6.8, 3.4	115/230	1	See Chart Above

JUNCTION BOX WIRING DIAGRAM

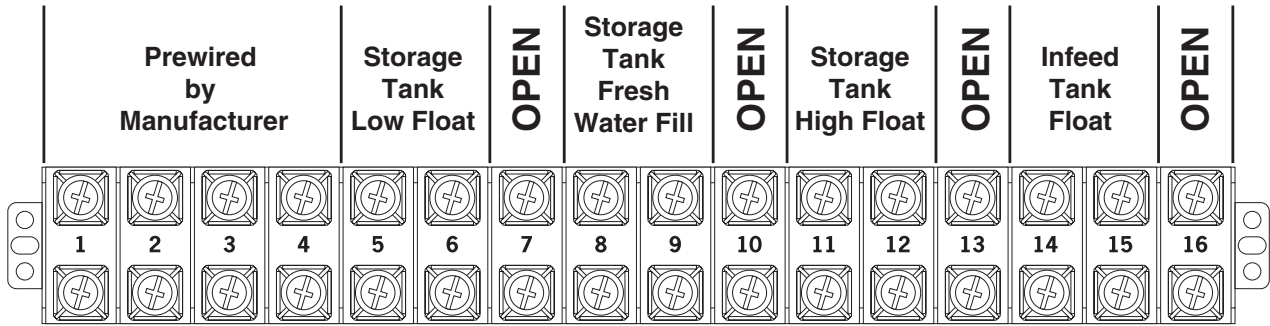

89174360-11

Bottom prewired by manufacturer

OZONE GENERATOR

Ozone...Nature's Purification Agent

Ozone is produced in nature or artificially by man. In the Earth's atmosphere, ozone is formed when oxygen is exposed to ultraviolet light or an electrical charge as during thunderstorms. Ozone's primary function in nature is to purify the air we breathe and screen us from harmful rays of the sun. In a similar fashion, Water Maze systems use ozone to disinfect water because ozone has a number of characteristics that make it ideal for water treatment.

Ozone's Characteristics:

Ozone is well suited for water treatment and its unique characteristics are described below:

- Ozone works up to 3,000 times faster than chlorine to kill bacteria and destroy harmful microorganisms.
- Ozone is a more powerful oxidizing agent than chlorine and bromine and has a better ability to remove water contamination.
- Ozone will not form harmful by-products, like THM's (a problem with drinking water) or chloramines (by-product of chlorine responsible for odors, skin irritations and burning eyes).
- Ozone will not alter the water's pH, thereby reducing pH fluctuations.
- Ozone coagulates small particles in water so clarity is dramatically improved.
- Ozone acts as a deodorizer removing unpleasant odors from water.

How the Water Maze Ozone System Works:

Because ozone is unstable, it cannot be packaged and used at a later date. For this reason, ozone is always produced where utilized.

Point-of-use-ozone generation is simple. This powerful disinfectant is produced from ambient air surrounding the generator using special ultraviolet lamps located inside the system's cabinet. To generate the ozone, air movement is created through the use of an air compressor or water venturi. As air passes over these unique lamps, the oxygen contained in the air is converted. The resulting ozone gas is subsequently introduced to the water in the inlet pipeline, where oxidation and disinfection immediately take place.

OZONE GENERATOR MAINTENANCE:



WARNING: Never look at an unshielded ozone lamp while operating the unit. This lamp will cause severe eye and skin damage. There is a green indicator light which will dim when the unit is operating properly and will turn bright green if there is a malfunction. See product description for location

of the indicator light.

LAMP TESTING PROCEDURE

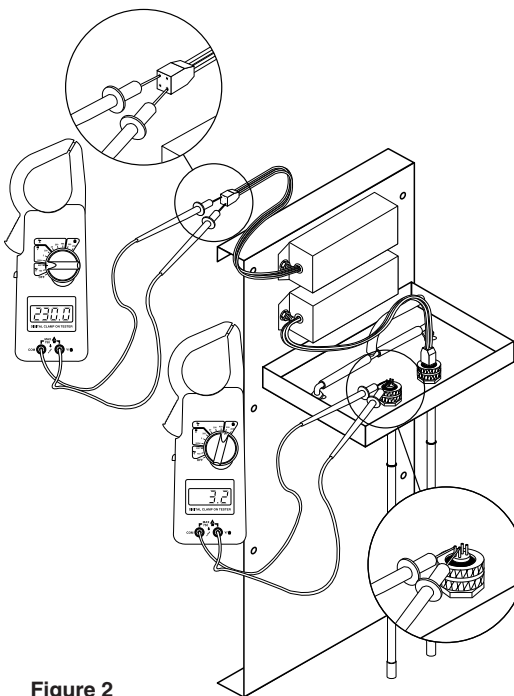

Figure 2

Lamp:

The light has a 9,000 hour life expectancy.

Testing the Lamp:

To test the ozone lamp use a voltmeter set on ohms. First, remove the ozone cover and unplug the lamp plug from the ozone lamp. **NOTE:** There are two filaments - an upper and a lower - inside the lamp. Place one of the voltmeter leads on one of the lamp prongs and, with the other lead, touch all of the three remaining prongs. If continuity is not achieved on both upper and lower filaments, replace the ozone lamp (Part #6-0534). (See figure 2 below.)

OZONE GENERATOR OPERATOR'S MANUAL

Testing the Ballast:

To test the power pack, use a voltmeter set on the correct voltage (230V). Place one of the voltmeter leads into the lamp plug where the white wire goes into it and plug the other voltmeter lead into the lamp plug where the blue wire goes into it. If no voltage is present, replace the ozone ballast (Part # 8.716-590.0) If the voltage tests out right and the bulb is good, but the bulb will still not turn on, replace the ballast. The internal starter in the ballast has gone bad.

Replacing the Lamp:

Lamps are available from your Water Maze Dealer should it need to be replaced. Simply turn off the power, remove the screws on the power pack cover and remove the cover. Disconnect the plug on the end of the ozone lamp. Now, loosen the lamp holder locking ring from around the end of the lamp by turning it counterclockwise and removing it. Remove the lamp by grabbing the rubber bushing around the end of the lamp and pulling it straight out. Remove the rubber bushing from the lamp and install it on your new lamp making sure the outer edge of the bushing is flush with the outer edge of the silver end cap on the lamp. Now, slide the lamp back into the reaction chamber. The lamp holder may now be reinstalled and tightened. Reinstall the plug onto the lamp and replace the power pack cover.

CAUTION: Keep the lamp free of fingerprints and dust particles by only handling the metal end caps on the lamp. You can clean the lamp with rubbing alcohol and a soft cloth. A dirty lamp will not allow maximum ozone output.

Specifications:

Energy required:

230VAC max., 800 Amp/Ballast

Power Consumption:

20 Watts

Average Lamp Life:

9,000 Hours

Lamp Wavelength:

185nm

OZONE GENERATOR OPERATOR'S MANUAL

OZONE GENERATOR EXPLODED VIEW (8.905-715.0)

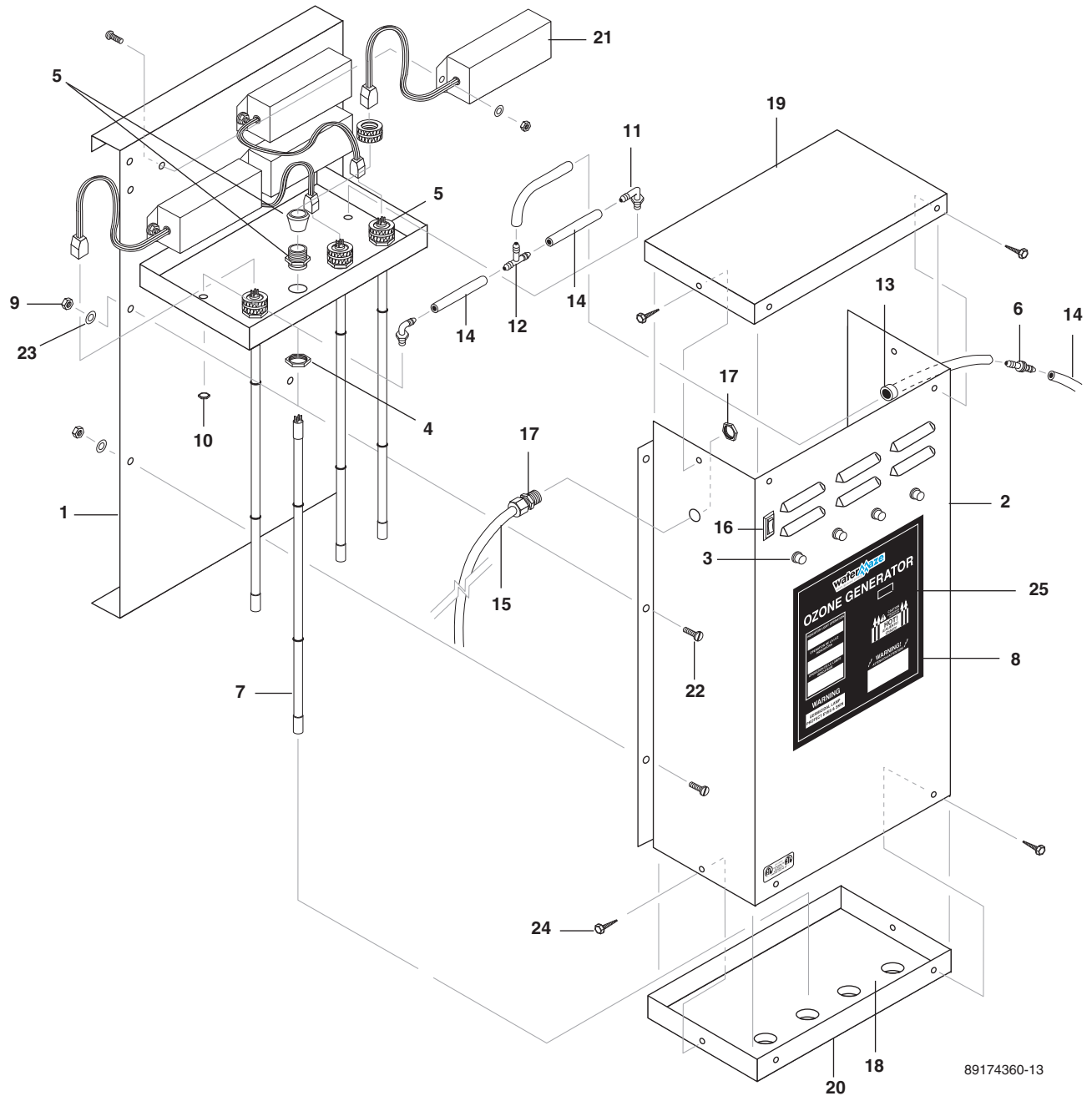

89174360-13

OZONE GENERATOR OPERATOR'S MANUAL

OZONE GENERATOR EXPLODED VIEW PARTS LIST

ITEM	PART NO.	DESCRIPTION	QTY
1	8.913-357.0	Ozone Box, Back, 400	1
2	8.913-360.0	Ozone Box, Front, 400	1
3	9.802-455.0	Light, Indicator, Green	4
4	9.802-523.0	Locknut, 3/4" Conduit	4
5	8.716-583.0	Connector, Aluminum Cord SCH1037	4
6	8.707-355.0	Ozone Check Valve	1
7	8.716-600.0	Lamp, Ozone Replacement	4
8	8.724-584.0	Label, Ozone Generator	1
9	9.802-696.0	Nut, 10/32", NF ST ST KEP	12
10	8.706-570.0	Locknut, 3/8", Nylon	2
11	8.706-585.0	Connector, 3/8" x 3/8", Male Elbow (Poly)	2
12	8.706-594.0	Tee, 3/8" Poly	1
13	8.706-733.0	Bushing, 1/2" Snap	1
14	8.711-733.0	Tubing, 3/8" x 1/2", Vinyl	6
15	9.802-423.0	Cord, Service, SEO, 16/3 /ft.	8
16	9.802-453.0	Switch, Curvette, 120V & 220V	1
17	9.802-515.0	Strain Relief, 1/2" NPT Ozone Gen	1
18	8.706-545.0	Cushion, 1/2", 13-3/4" x 5-3/4", Rubber, 400	1
19	8.913-358.0	Ozone Box, Top, 400	1
20	8.913-359.0	Ozone Box, Bottom, 400	1
21	8-716-590.0	Ballast, 120/240V, Ozone Generator	4
22	9.804-566.0	Screw, 10/32" x 1/2" Slot Pan MS ZN	12
23	8.718-968.0	Washer, 10 x SAE ZN	12
24	9.802-798.0	Screw, #10 x 1/2" Tek Hex Head	8
25	8.900-511.0	Label, 220V, Ozone Generator	1



WARRANTY

ACCESSORIES AND PARTS WARRANTY

LIMITED MINIMUM 90 DAY WARRANTY

We warrant to the original consumer that each new part and accessory sold by Watermaze will be free from manufacturing defects in materials or workmanship in normal service for the duration specified by the original component manufacturer with a 90 day minimum from date of purchase, provided it is installed properly and the equipment is maintained in accordance with Watermaze instructions and manuals. Components manufactured by Watermaze such as frames, and handles have a 2 year warranty from date of purchase.

Our obligation under this warranty is expressly limited as to the replacement or repair, at our option, at Watermaze Camas, Washington 98607, or at a service facility designated by us, for such part or parts as inspection shall disclose to have been defective.

EXCLUSIONS:

This warranty does not apply to defects caused by casualty or unreasonable use, including faulty repairs by others and failure to provide reasonable and necessary maintenance.

LIMITATION OF LIABILITY

Watermaze's liability for special, incidental, or consequential damages is expressly disclaimed. In no event shall Watermaze liability exceed the purchase price of the product in question. Watermaze makes every effort to ensure that all illustrations and specifications are correct, however, these do not imply a warranty that the product is merchantable or fit for a particular purpose, or that the product will actually conform to the illustrations and specifications. Our obligation under this warranty is expressly limited at our option to the replacement or repair at a service facility or factory designated by us, of such part or parts as inspection shall disclose to have been defective. **THE WARRANTY CONTAINED HEREIN IS IN LIEU OF ALL OTHER WARRANTIES, EXPRESS OR IMPLIED, INCLUDING ANY IMPLIED WARRANTY OF MERCHANTABILITY OR FITNESS FOR A PARTICULAR PURPOSE ARE EXPRESSLY LIMITED TO THE DURATION OF THIS WRITTEN WARRANTY.** This warranty gives you specific legal rights and you may also have other rights which vary from state to state. Watermaze does not authorize any other party, including authorized Watermaze Distributors, to make any representation or promise on behalf of Watermaze, or to modify the terms, products conforms to local codes, While Watermaze attempts to assure that its products meet national codes, it cannot be responsible for how the customer chooses to use or install the product. Some states do not allow limitations on how long an implied warranty lasts or the exclusion or limitation of incidental or consequential damages, so the above limitation or exclusion may not apply to you.

TO OBTAIN WARRANTY SERVICE:

Purchaser must bring the accessory parts to an authorized Watermaze Distributor. For the distributor nearest you consult our web page: www.wmaze.com or write: Watermaze, 4275 NW Pacific Rim Blvd, Camas, WA 98607.



LIMITED NEW PRODUCT WARRANTY WASH WATER / WATER TREATMENT SYSTEMS

WHAT THIS WARRANTY COVERS

All *WATER MAZE* water treatment systems are warranted by the original purchaser to be free from defects in materials and workmanship under normal use, for the periods specified below. This Limited Warranty, subject to the exclusions shown below, is calculated from the date of the original purchase, and applies to the original components only. Any parts replaced under this warranty will assume the remainder of the part's warranty period. A 60 day grace period will be given for installation.

ONE YEAR PARTS AND 30 DAY LABOR WARRANTY:

All components excluding normal wear items as described below.

WARRANTY PROVIDED BY OTHER MANUFACTURERS:

Motors, which are warranted by their respective manufacturers, are serviced through these manufacturers' local authorized service centers. *WATER MAZE* cannot provide warranty on these items.

WHAT THIS WARRANTY DOES NOT COVER

This warranty does not cover the following items:

1. Normal wear items, such as seals, filters, gaskets, O-rings, packings, pistons, brushes, filtering media, ozone bulbs, sensors, UV scanners, oil-skimmer belt, impedance sensor. Minor leaks covered first time on original start-up only.
2. Damage or malfunctions resulting from accidents, abuse, modifications, alterations, incorrect installation, improper servicing, failure to follow manufacturer's maintenance instructions, or use of the equipment beyond its stated usage specifications as contained in the operator's manual.
3. Damage due to freezing, sludge build-up, chemical deterioration (oxidation, chloride or fluoride corrosion), and rust.
4. Damage to components from fluctuations in electrical or water supply.
5. Normal maintenance service, including adjustments.
6. Transportation to service center, field labor charges, or freight damage.
7. Consumables and water quality.

WHAT YOU MUST DO TO OBTAIN WARRANTY SERVICE

While not required for warranty service, we request that you register your *WATER MAZE* Product by returning the completed registration card. In order to obtain warranty service on items warranted by *WATER MAZE*, you must return the product to your Authorized *WATER MAZE* Dealer, freight prepaid, with proof of purchase, within the applicable warranty period. If the product is permanently installed, you must notify your Authorized *WATER MAZE* Dealer of the defect. Your Authorized *WATER MAZE* Dealer will file a claim with *WATER MAZE*, who must subsequently verify the defect. In most cases, the part must be returned to *WATER MAZE* freight prepaid with the claim. For warranty service on components warranted by other manufacturer's, your Authorized *WATER MAZE* Dealer can help you obtain warranty service through these manufacturers' local authorized service centers.

LIMITATION OF LIABILITY

WATER MAZE'S liability for special, incidental, or consequential damages is expressly disclaimed. In no event shall *WATER MAZE'S* liability exceed the purchase price of the product in question. *WATER MAZE* makes every effort to ensure that all illustrations and specifications are correct, however, these do not imply a warranty that the product is merchantable or fit for a particular purpose, or that the product will actually conform to the illustrations and specifications. Our obligation under this warranty is expressly limited at our option to the replacement or repair at a service facility or factory designated by us, of such part or parts as inspection shall disclose to have been defective. **THE WARRANTY CONTAINED HEREIN IS IN LIEU OF ALL OTHER WARRANTIES, EXPRESS OR IMPLIED, INCLUDING ANY IMPLIED WARRANTY WATER QUALITY, MERCHANTABILITY OR FITNESS FOR A PARTICULAR PURPOSE ARE EXPRESSLY LIMITED TO THE DURATION OF THIS WARRANTY.** This warranty gives you specific legal rights and you may also have other rights which vary from state to state. *WATER MAZE* does not authorize any other party, including authorized *WATER MAZE* Distributors, to make any representation or promise on behalf of *WATER MAZE*, or to modify the terms, conditions, or limitations in any way. It is the buyer's responsibility to ensure that the installation and use of *WATER MAZE* products conforms to local codes. While *WATER MAZE* attempts to assure that its products meet national codes, it cannot be responsible for how the customer chooses to use or install the product. Some states do not allow limitations or exclusion or limitation of incidental or consequential damages, so the above limitation or exclusion may not apply to you.

