



# HWE

## OPERATOR'S MANUAL

---

■ HWE-4020C

■ HWE-4030C

---



---

For technical assistance or the Hotsy Dealer nearest you, consult our web page at [www.Hotsy.com](http://www.Hotsy.com) or call 360-833-1600

# CONTENTS

---

Introduction & Important Safety Information	3-4
Pre-Operation Check	4
Component Identification	5
Assembly Instructions	6-7
Operating Instructions	8
Detergents & General Cleaning Techniques	9
Shut Down Procedures	10
Storage	10
Preventative Maintenance & Oil Change Record	11
Maintenance	12
Troubleshooting	13-15
V ä[[â\ ç	

Model Number \_\_\_\_\_

Serial Number \_\_\_\_\_

Date of Purchase \_\_\_\_\_

The model and serial numbers will be found on a decal attached to the pressure washer. You should record both serial number and date of purchase and keep in a safe place for future reference.

# INTRODUCTION & IMPORTANT SAFETY INFORMATION

Thank you for purchasing a Hotsy Pressure Washer.

This manual covers the operation and maintenance of the HWE-4020C and HWE-4030C washers. All information in this manual is based on the latest product information available at the time of printing.

Hotsy, Inc. reserves the right to make changes at any time without incurring any obligation.

## Owner/User Responsibility:

The owner and/or user must have an understanding of the manufacturer's operating instructions and warnings before using this Hotsy pressure washer. Warning information should be emphasized and understood. If the operator is not fluent in English, the manufacturer's instructions and warnings shall be read to and discussed with the operator in the operator's native language by the purchaser/owner, making sure that the operator comprehends its contents.

Owner and/or user must study and maintain for future reference the manufacturers' instructions.

**This manual should be considered a permanent part of the machine and should remain with it if machine is resold.**

**When ordering parts, please specify model and serial number.**

## IMPORTANT SAFETY INSTRUCTIONS

**WARNING: When using this machine basic precautions should always be followed, including the following:**

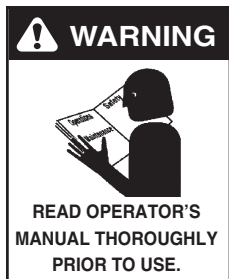

**WARNING: To reduce the risk of injury, read operating instructions carefully before using.**

1. Read the owner's manual thoroughly. Failure to follow instructions could cause malfunction of the machine and result in death, serious bodily injury and/or property damage.
2. Know how to stop the machine and bleed pressures quickly. Be thoroughly familiar with the controls.
3. Stay alert — watch what you are doing.
4. All installations must comply with local codes. Contact your electrician, plumber, utility company or the selling distributor for specific details.
5. This machine requires that it be installed by a qualified electrician. This product shall only be connected to a power supply receptacle protected by a ground fault circuit interrupter.



**WARNING: Keep water spray away from electric wiring or fatal electric shock may result.**

6. To protect the operator from electrical shock, the machine must be electrically grounded. It is the responsibility of the owner to connect this machine to a UL grounded

Receptacle of proper voltage and amperage ratings. Do not spray water near electrical components. Do not touch machine with wet hands or while standing in water. Always disconnect power before servicing.

**CAUTION: Spray gun kicks back — hold with both hands.**

7. Grip spray-gun and wand securely before starting this machine. Failure to do this could result in bodily injury from a whipping wand.



**WARNING: Flammable liquids can create fumes which can ignite causing property damage or severe injury.**

**WARNING: Risk of fire. Do not install or operate near any flammable liquids.**

**WARNING: Before obtaining access to electric terminals, all supply circuits must be disconnected.**

9. Electrical appliances shall be installed only in locations where combustible dusts and flammable gases or vapors are not present. Do not store or use gasoline near this machine.



**WARNING: High pressure developed by these machines will cause personal injury or equipment damage. Keep clear of nozzle. Use caution when operating. Do not direct discharge stream at people, or severe injury or death will result.**

**WARNING: Risk of injection or severe injury. Keep clear of nozzle. Do not direct discharge stream at persons. This equipment is to be used only by trained operators.**

10. Never make adjustments on machine while it is in operation.

## IMPORTANT SAFETY INFORMATION



**WARNING:** *High pressure spray can cause paint chips or other particles to become airborne and fly at high speeds. To avoid personal injury, eye and foot safety devices must be worn.*

11. Eye, hand and foot safety devices must be worn when using this equipment.
12. Machines with spray guns should not be operated with the spray gun in the off position for extended periods of time as this may cause damage to the pump.
13. Protect from freezing.
14. Protect discharge hose from vehicle traffic and sharp objects.
15. To prevent a serious injury, be certain quick coupler on discharge hose has locked before using pressure washer.
16. Before disconnecting discharge hose from hot water outlet, disconnect power supply, open spray gun to relieve back pressure in hose and use protective gloves.
17. Do not allow acids, caustic or abrasive fluids to pass through the pump.
18. Inlet water supply must be cold and clean fresh water.
19. The best insurance against an accident is precaution and knowledge of the machine.
20. Hotsy will not be liable for any changes made to our standard machines, or any components not purchased from Hotsy.
21. To reduce the risk of injury, close supervision is necessary when a machine is used near children. Do not allow children to operate the pressure washer. **This machine must be attended during operation.**
22. Do not overreach or stand on unstable support. Keep good footing and balance at all times.
23. Follow the maintenance instructions specified in the manual.
24. When making repairs disconnect from electrical source.
25. Do not operate this product when fatigued or under the influence of alcohol or drugs. Keep operating area clear of all persons.
26. **WARNING: Do not use below garage floor or grade level.**

## PRE-OPERATION CHECK

- Heat module water level
- Pump oil (SAE 30W non-detergent oil)
- Cold water supply (6 gpm • 5/8" • 20 psi)
- Proper power supply
- Hose, wand, nozzles (nozzle sizes per serial plate)
- Water filter (intact, non restrictive)
- Read installation and operation instructions



**Follow the maintenance instructions specified in the manual.**

# COMPONENT IDENTIFICATION

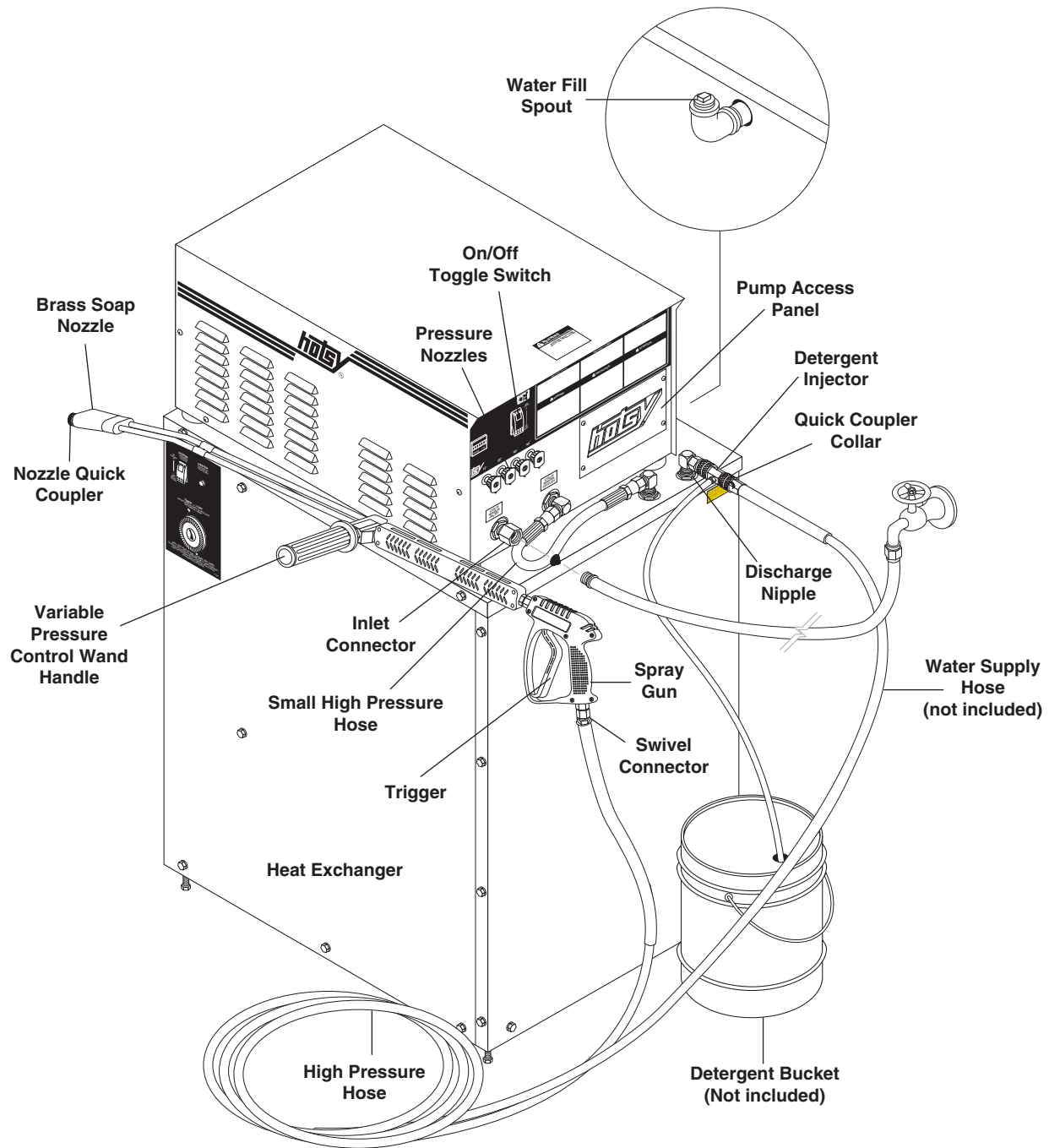

**Pump** — Delivers a specific gpm to the high pressure nozzle which develops pressure.

**Spray Gun** — Controls the application of water and detergent onto cleaning surface with trigger device. Includes safety latch.

**Detergent Injector** — Allows you to siphon and mix detergents.

**Wand** — Must be connected to the spray gun.

**Heat Exchanger** — Has a stainless steel coil suspended into an 80 gallon water tank that is heated to 200° by heating elements.

**High Pressure Hose** — Connect one end to water pump high pressure discharge nipple and the other end to spray gun.

**Unloader Valve** — Safety device which, when the spray gun closes, prevents over pressurization (Not Shown.)

**NOTE:** If trigger on spray gun is released for more than 2 minutes, water will leak from the pump protector. Warm water will discharge from pump protector onto floor. This system prevents internal pump damage.

# ASSEMBLY INSTRUCTIONS

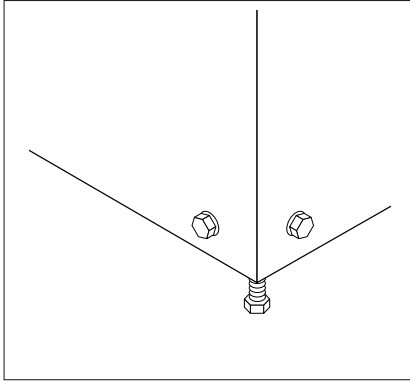

**STEP 1:** Place machine in a convenient location providing ample support, drainage and room for maintenance. Remove pallet bolts and remove pallet, then re-install bolts to level machine by adjusting (machine must be level).

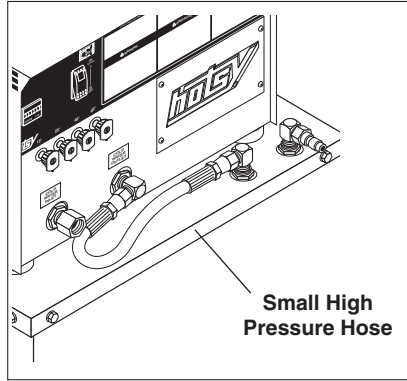

**STEP 2:** Place the pump package on top of the heat exchange and attach the small high pressure hose to the fittings as shown.

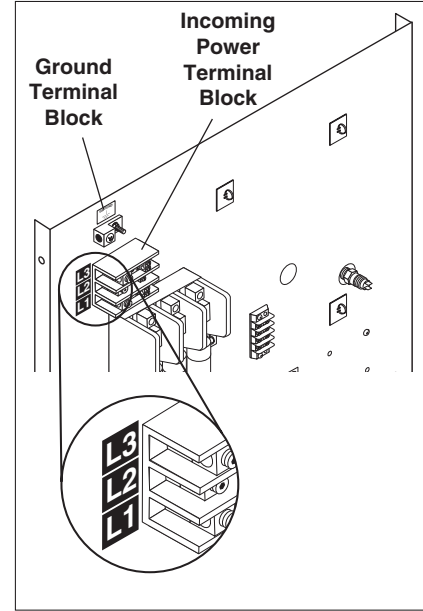

**STEP 3:** Remove the hex head screws from electrical access panel. **NOTE:** bottom right screw will only loosen; access panel is designed to pivot on this screw. Once access panel is rotated out of the way, attach the electrical harness from the pressure washer to the heating module as follows:

- a. Feed pressure washer wire harness through the upper wire hole located on the side of the machine (See item 16 on page 20).
- b. On the right side of the incoming power terminal block, connect the black wire to line L1, the red wire to line L2, and the white wire to line L3.
- c. Attach the green wire to the ground terminal block.

**CAUTION:** Have qualified electrician attach the proper supply cord to the terminal labeled L1, L2 and L3.

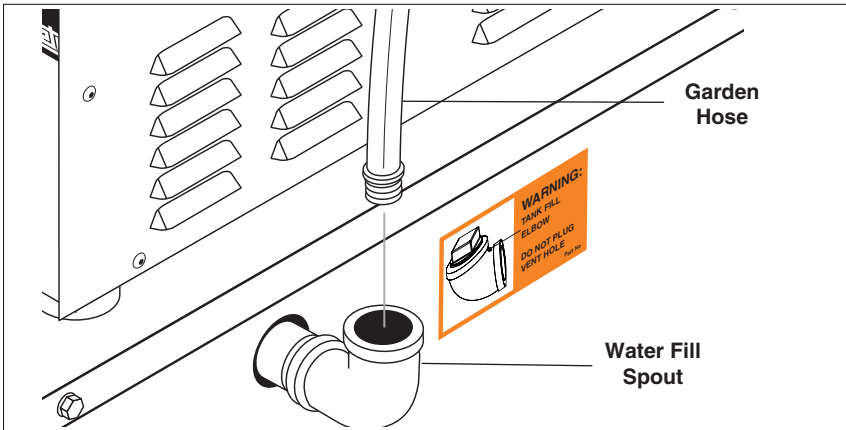

**STEP 4:** Do not turn power on to equipment until the heating module is filled with water, as severe damage may occur to heater elements.

Prior to shipping, a rust inhibitor powder was added to the hot water tank. This powder will mix with the added water to prevent rust build-up inside the tank.

Install water fill spout (item 15, page 20, shipped loose). Spout opening should be facing up. Insert water hose and fill. Do not over fill to allow for thermal expansion. (Maximum is 80 gallons). After heater tank has been filled to the top, operate for one week and then add one quart of oil to slow evaporation. Be sure to replace spout plug, hand tight only.

Turn on main power supply to unit. Set 7 day programmable timer to desired ON/OFF time and switch machine power on, Water will heat up to operating temperature in 30 to 60 minutes. The heater will turn off automatically when 200°F is reached. Water will come out of heater fill spout due to heat expansion. However, this will stop after temperature is reached.

Leave main power on to the machine to ensure hot water on pump start up.

# ASSEMBLY INSTRUCTIONS

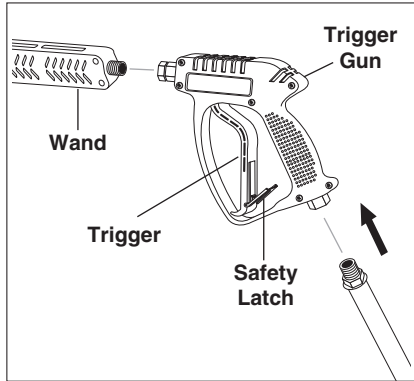

**STEP 5:** Attach variable pressure control wand to spray gun using teflon tape on threads to prevent leakage. Position safety latch to prevent trigger from being pulled.

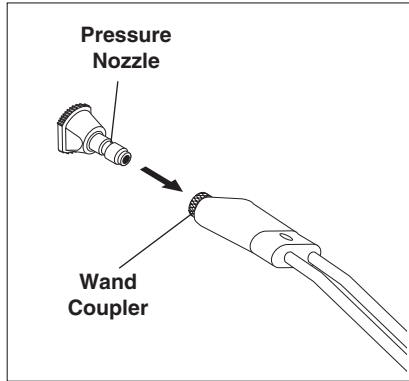

**STEP 6:** Pull the spring-loaded collar of the wand coupler back to insert your choice of pressure nozzle. **CAUTION: Never replace nozzles without engaging the safety latch on the spray gun trigger.**

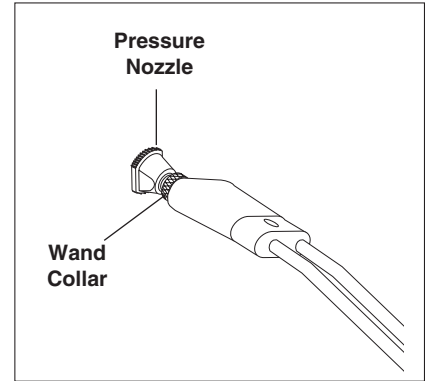

**STEP 7:** Release the coupler collar and push the nozzle until the collar clicks. Pull the nozzle to make sure it is seated properly.

**WARNING: These machines are designed for indoor use. Machine must be stored indoors when not in use.**

# OPERATING INSTRUCTIONS

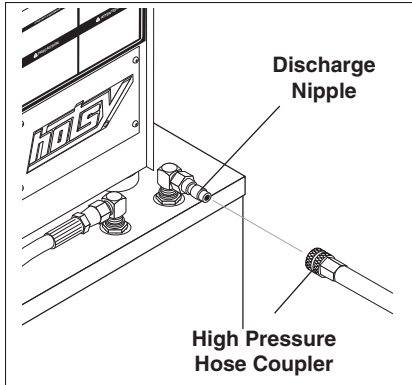

**STEP 1:** Connect the high pressure hose quick coupler to the discharge nipple by sliding the quick coupler collar back and inserting the quick coupler onto the discharge nipple and pushing the quick coupler collar forward to secure it. Secure desired pressure nozzle into variable pressure wand coupler.

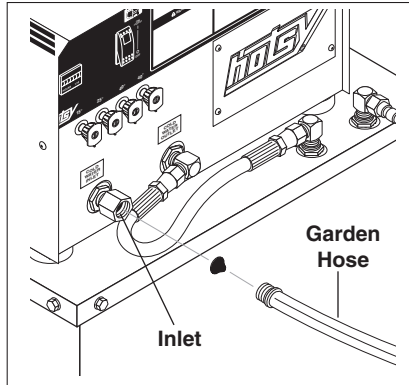

**STEP 2:** Connect water supply hose (garden hose) to inlet connector. Do not allow acid or abrasives to be pumped through system. Turn on water.

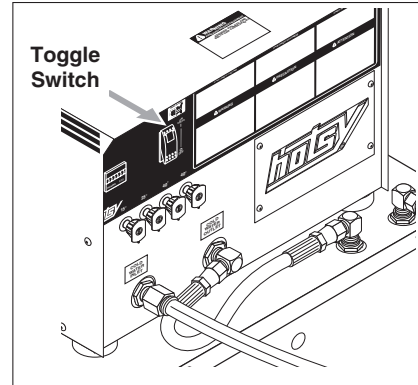

**STEP 3:** Place toggle switch in the ON position and then pull the trigger on the spray gun to activate a pressure switch which will then start the machine. The ON position is for auto shut down.

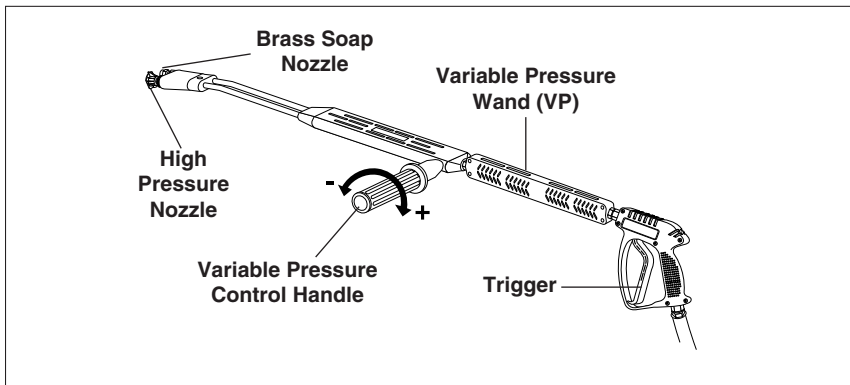

**STEP 4:** Turn the variable pressure control handle clockwise to increase pressure.

Selection of high or low pressure is accompanied by turning the handle. **NOTE:** High pressure nozzle must be inserted at end of wand to obtain high pressure. To apply soap read Detergents & General Cleaning Techniques section.

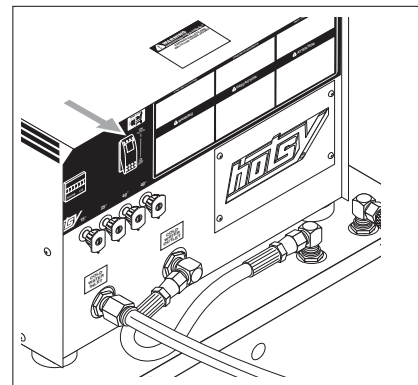

**STEP 5:** To stop machine, release the spray gun and machine will automatically stop in approximately 12 seconds. If machine is going to be unattended for long periods of time, turn water supply off and place switch in OFF position.

**NOTE:** When removing or replacing hoses, wand and nozzles, move switch to OFF position, open spray gun to release pressure before removing discharge hose.



# DETERGENTS & GENERAL CLEANING TECHNIQUES

## WARNING

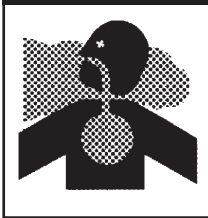

**WARNING:** Some detergents may be harmful if inhaled or ingested, causing severe nausea, fainting or poisoning. The harmful elements may cause property damage or severe injury.

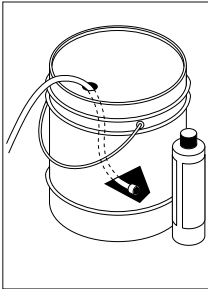

**STEP 1:** Use detergent designed specifically for pressure washers. Household detergents could damage the pump. Prepare detergent solution as required by the manufacturer. Fill a container with pressure washer detergent. Place the filter end of detergent suction tube into the detergent container.

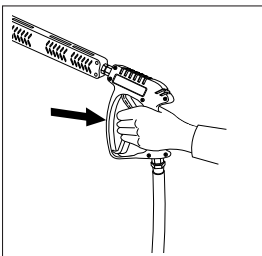
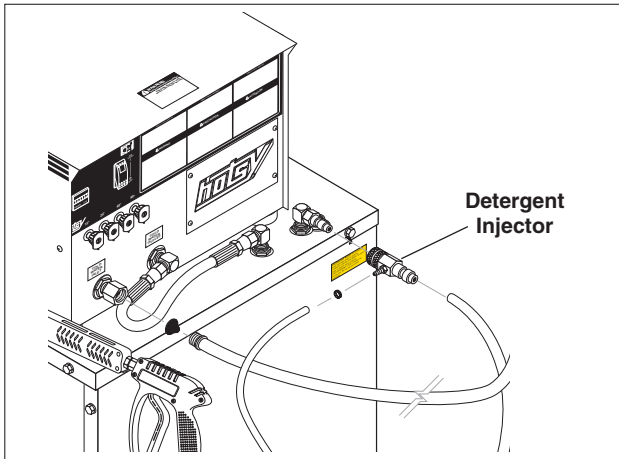

**STEP 2:** Apply safety latch to spray gun trigger. Open variable pressure wand handle to low pressure which allows water through black detergent nozzle. **NOTE:** Detergent cannot be applied during high pressure.

**STEP 3:** With the motor running, pull trigger to operate machine. Liquid detergent is drawn into the machine and mixed with water. Apply detergent to work area. Do not allow detergent to dry on surface.

**IMPORTANT:** You must flush the detergent injection system after each use by placing the suction tube into a bucket of clean water, then run the pressure washer in low pressure for 1-2 minutes.

## THERMAL PUMP PROTECTION

If you run your pressure washer for 3-5 minutes without pressing the trigger on the spray gun, circulating water in the pump can reach high temperatures. When the water reaches this temperature, the pump protector engages and cools the pump by discharging the warm water onto the ground. This thermal device prevents internal damage to the pump.

## CLEANING TIPS

Pre-rinse cleaning surface with fresh water. Place detergent suction tube directly into cleaning solution and apply to surface at low pressure (for best results, limit your work area to sections approximately 6 feet square and always apply detergent from bottom to top). Allow detergent to remain on surface 1-3 minutes. Do not allow detergent to dry on surface. If surface appears to be drying, simply wet down surface with fresh water. If needed, use brush to remove stubborn dirt. Rinse at high pressure from top to bottom in an even sweeping motion keeping the spray nozzle approximately 1 foot from cleaning surface. Use overlapping strokes as you clean and rinse any surface. For best surface cleaning action spray at a slight angle.

## Recommendations:

- Before cleaning any surface, an inconspicuous area should be cleaned to test spray pattern and distance for maximum cleaning results.
- If painted surfaces are peeling or chipping, use extreme caution as pressure washer may remove the loose paint from the surface.
- Keep the spray nozzle a safe distance from the surface you plan to clean. High pressure wash a small area, then check the surface for damage. If no damage is found, continue to pressure washing.

## CAUTION - Never use:

- Bleach, chlorine products and other corrosive chemicals
- Liquids containing solvents (i.e., paint thinner, gasoline, oils)
- Tri-sodium phosphate products
- Ammonia products
- Acid-based products

These chemicals will harm the machine and will damage the surface being cleaned.

## RINSING

It will take a few seconds for the detergent to clear. Apply safety latch to spray gun. Turn variable pressure control handle to high pressure. **NOTE:** You can also stop detergent from flowing by simply removing detergent siphon tube from bottle.

## SHUTDOWN PROCEDURES

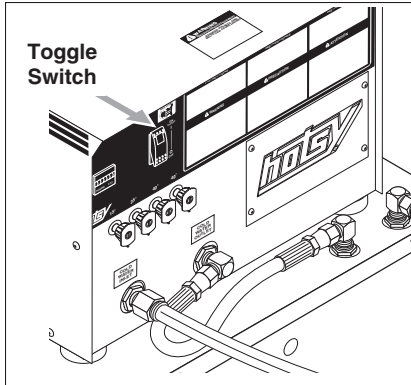

**STEP 1:** Rinse all lines (and injector) with clean water, to remove any soap residue then turn toggle switch off.

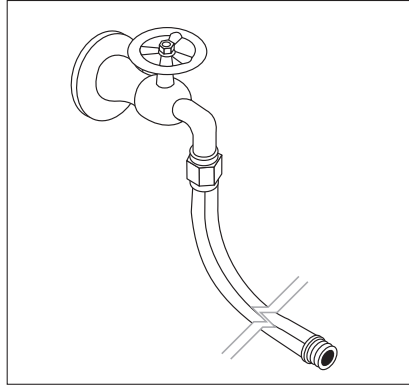

**STEP 2:** Turn off water supply.

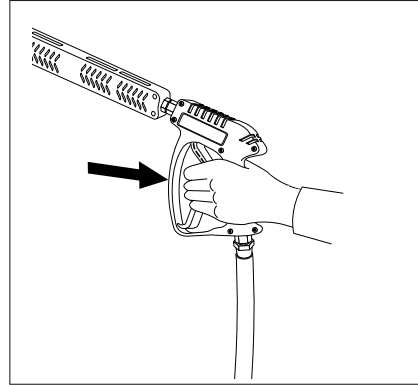

**STEP 3:** Open spray gun to relieve remaining pressure and remove water supply hose.

In freezing conditions, disconnect water supply and open spray gun to allow water to drain, then turn off motor.

**CAUTION:** Do not allow pump to run longer than 5 minutes without water. Disconnect all hoses to allow water to drain.

**CAUTION:** With machine off, open spray gun to release pressure before removing discharge hose.

## STORAGE

### Pump Storage



**CAUTION**

**CAUTION:** Always store your pressure washer in a location where the temperature will not fall below 32° F (0° C). The pump in this machine is susceptible to permanent damage if frozen.

**FREEZE DAMAGE IS NOT COVERED BY WARRANTY.**

If you must store your pressure washer in a location where the temperature is below 32° F, you can minimize the chance of damage to your machine by draining your machine as follows:

1. Stop the pressure washer and detach supply hose and high pressure hose. Squeeze the trigger of the spray gun to drain all water from the wand and hose.
2. Restart pressure washer and let it run briefly (about 5 seconds) until water no longer discharges from the high pressure outlet.

## PREVENTATIVE MAINTENANCE

This pressure washer was produced with the best available materials and quality craftsmanship. However, you as the owner have certain responsibilities for the correct care of the equipment. Attention to regular preventative maintenance procedures will assist in preserving the performance of your equipment. Contact your Hotsy dealer for maintenance. Regular preventative maintenance will add many hours to the life of your pressure washer. Perform maintenance more often under severe conditions.

Pump Oil	Inspect	Daily inspect the oil level
	Change	After first 50 hours, then every 500 hours or annually
Replace High Pressure Nozzle		Every 6 months
Replace Quick Connect		Annually
Clean Water Screen/Filter		Weekly
Replace HP Hose		Annually if there is any sense of wear
Grease Motor		Every 10,000 hours
Inspect Heater Module Tank Water Level		Weekly

## OIL CHANGE RECORD

Date Oil Changed Month/Day/Year	Estimated Operating Hours Since Last Oil Change

---

## MAINTENANCE

---

**Daily:**

To ensure a problem free system, simple visual checks can be performed. Check for leaks in inlet supply, pumping system, pump to heater hose, heater, spray gun(s) and high pressure hose. Check for normal operating functions and pump oil level/condition. Check nozzle condition. If badly worn or leaking conditions are found, qualified personnel should repair or replace components with new original or equivalent manufacturers parts.

Check equipment for proper operation. Nozzle spray should be uniform in flow, angle, and pressure. Clean if nozzle is plugged and replace if worn. If a heavy pulsation in the hose or spray is observed, repair of the pumping system is required.

**Weekly:**

After the first week of operation, it is recommended 1 quart (1 litre) of motor oil be added to the heat exchanger tank through the 1-1/4" fill pipe. This oil creates a vapor barrier and slows evaporation of water in the tank.

Check heat exchanger water level. The level must be up to the filler pipe neck. Add water if necessary. If cold water has been added, heating may cause the expanding water to escape through the filler plug. This will stop after operating temperature has been reached.

**Monthly:**

Check system for operation. Automatic start/stop, hot high pressure water, and smooth operation should be noted.

Change oil in pump crankcase. Note the condition of the oil when drained. If found to be creamy, water seals in pump may have to be removed and replaced.

## TROUBLESHOOTING

<b>PROBLEM</b>	<b>POSSIBLE CAUSE</b>	<b>SOLUTION</b>
<b>LOW OPERATING PRESSURE</b>	Faulty pressure gauge	Install new gauge.
	Insufficient water supply	Use larger garden hose; clean filter washer at water inlet.
	Old, worn or incorrect spray nozzle	Match nozzle number to machine and/or replace with new nozzle.
	Plumbing or hose leak	Check plumbing system for leaks. Retape leaks with teflon tape.
	Faulty or misadjusted unloader valve (where applicable)	Adjust unloader for proper pressure. Install repair kit when needed.
	Worn packing in pump	Install new packing kit.
	Fouled or dirty inlet or discharge valves in pump	Clean inlet and discharge valves.
	Worn inlet or discharge valves	Replace with valve kit.
	Leaking pressure control valve (where applicable)	Rebuild or replace as needed.
<b>FLUCTUATING PRESSURE</b>	Valves worn	Check and replace if necessary.
	Blockage in valve	Check and clean out if necessary.
	Pump sucking air	Check water supply and suction line for air seepage at joints.
	Worn piston packing	Check and replace if necessary.
<b>PRESSURE LOW AFTER PERIOD OF NORMAL USE</b>	Nozzle worn	Check and replace if necessary.
	Inlet or discharge valves blocked or worn	Check and clean or replace if necessary.
	Unloader valve seat worn	Check and replace if necessary.
<b>PUMP NOISY</b>	Air in suction line	Check water supply connections on suction line.
	Broken or weak inlet or discharge valve springs	Check and replace if necessary.
	Foreign matter in valves	Check and clean if necessary.
	Worn bearings	Check and replace if necessary.
<b>PRESENCE OF WATER IN PUMP OIL</b>	Water sprayed at machine	Change oil. Direct spray away from machine.
	High humidity in air	Check and change oil twice as often.
	Piston packing worn. Oil seal worn	Check and replace if necessary.

## TROUBLESHOOTING

PROBLEM	POSSIBLE CAUSE	SOLUTION
<b>OIL SQUIRTS OUT OF OIL CAP ON PUMP</b>	Pump overfilled with oil	Maintain oil level at red dot on sight glass at rear of pump or at top of notch on dipstick (where applicable).
<b>WATER DRIPPING FROM UNDER PUMP</b>	Piston packing worn	Check and replace if necessary.
	O-Ring plunger retainer worn	Check and replace if necessary.
	Cracked piston	Check and replace if necessary.
<b>OIL DRIPPING</b>	Oil seal worn	Check and replace if necessary.
<b>EXCESSIVE VIBRATION IN DELIVERY LINE</b>	Irregular functioning of the valves	Check and replace if necessary.
<b>SYSTEM WILL NOT START</b>	Power, water, auto switch not on	Check and turn on.
	Motor overload tripped	Check and reset.
	Control fuse blown (2 or 3 amp)	Check and replace.
	Pressure switch faulty	Check, clean or replace.
	Timer faulty	Check and replace.
<b>SYSTEM WILL NOT STOP</b>	Water leak in discharge line	Repair water leak.
	Pressure switch faulty	Disconnect at timer. If unit stops, replace pressure switch.
	Timer resistor faulty	Replace timer.
<b>SYSTEM STOPS AFTER APPROXIMATELY 10 SECONDS AND THEN RESTARTS</b>	Faulty pressure switch	Check and replace.
	Leak in system	Fix leak.
<b>WATER IS NOT HOT</b>	Tank water low	Check for leaks and fill.
	Temperature or level controls faulty	Check and replace.
<b>MOTOR "HUMS" BUT DOES NOT TURN</b>	Electric motor single phasing	Check for blown fuse or loose power line connections.
<b>PUMP RUNNING NORMALLY BUT LOW WATER PRESURE</b>	Air leak in inlet	Check water supply and possibility of air entering water connections.
	Faulty pressure unloader	Bypass pressure unloader by wiring spray gun open. If good PSI, turn machine off and replace regulator. <b>DO NOT RELEASE SPRAY GUN WHILE BYPASSING UNLOADER.</b>

## TROUBLESHOOTING

PROBLEM	POSSIBLE CAUSE	SOLUTION
<b>WATER ESCAPING FROM FILL PIPE ON HEAT EXCHANGER</b>	Cold water added to heat exchanger	Will stop once at operating temperature.
	Ruptured coil or leaking	Check, repair or replace fittings.
<b>UNLOADER DOES NOT GO INTO BYPASS OR WILL CYCLE ITSELF</b>	Spray gun or hose is leaking to atmosphere	Check and repair all leaks.
	Check plunger either did not move or did not seal	Remove discharge port. Clean and inspect the check plunger. Replace the o-ring if needed.
	Actuator o-ring failure	Remove actuator plunger assembly and inspect o-ring and back-up rings. Replace if necessary.
<b>SPIKES TOO HIGH</b>	Slow moving actuator; this may be caused by bad o-rings either on the plunger or inside the actuator fitting.	Remove the actuator assembly to inspect the o-ring and back-up rings. The actuator assembly will have to be disassembled to inspect and/or replace the o-rings in the actuator fitting.
	Spring tension	Adjustment should stop when pressure is no longer affected by further compression of the spring.
	Hose length	Hose length can affect the amount of spike pressure. Long lengths of hose may cause high spike pressures.
<b>SYSTEM WON'T COME UP TO PRESSURE</b>	Water is leaking between ball and seat	Disassemble inlet fitting and check for contaminants or worn parts. Clean or replace as needed.
	O-Rings on actuator plunger are bad	Remove actuator assembly and inspect o-ring and back-up rings. Replace if necessary.
	Locknut may be improperly set	Readjust locknut. <b>NOTE:</b> The locknut is inside the spring on models that have the stem exposed above the spring.
	Tip/GPM combination is incorrect	Check actual GPM on unrestricted pump and size tip accordingly.
	Tip worn- the GPM may be greater than expected with a worn tip	Replace tip.
	Bad gauge - the pressure may be higher than the gauge shows	Replace gauge.



**HOTSY LIMITED NEW PRODUCT WARRANTY  
PRESSURE WASHERS  
WHAT THIS WARRANTY COVERS**

All Hotsy pressure washers are warranted by Hotsy to the original purchaser to be free from defects in materials and workmanship under normal use, for the periods specified below. This Limited Warranty is subject to the exclusions shown below, is calculated from the date of the original purchase, and applies to the original components only. Any parts replaced under this warranty will assume the remainder of the part's warranty period.

**SEVEN YEAR PARTS AND ONE YEAR LABOR WARRANTY:**

Components manufactured by Hotsy, such as frames, handles, top and bottom wraps, float tanks, fuel tanks, belt guards, and internal components on the oil-end of HOTSYS manufactured pumps. General, AR, Liberty, Comet and swash and wobble plate pumps have a one year warranty. Heating coils have a five year warranty from date of original machine purchase.

**ONE YEAR PARTS AND ONE YEAR LABOR WARRANTY:**

All other components, excluding normal wear items as described below, will be warranted for one year on parts and labor. Parts and labor warranty on these parts will be for one year regardless of the duration of the original component manufacturer's part warranty.

**WARRANTY PROVIDED BY OTHER MANUFACTURERS:**

Motors, generators, and engines, which are warranted by their respective manufacturers, are serviced through these manufacturers' local authorized service centers. Hotsy is not authorized and has no responsibility to provide warranty service for such components.

**WHAT THIS WARRANTY DOES NOT COVER**

This warranty does not cover the following items:

1. Normal wear items, such as nozzles, spray guns, discharge hoses, wands, quick couplers, seals, filters, gaskets, O-rings, packings, pistons, pump valve assemblies, strainers, belts, brushes, rupture disks, fuses, pump protectors.
2. Damage or malfunctions resulting from accidents, abuse, modifications, alterations, incorrect installation, improper servicing, failure to follow manufacturer's maintenance instructions, or use of the equipment beyond its stated usage specifications as contained in the operator's manual.
3. Damage due to freezing, chemical deterioration, scale build up, rust, corrosion, or thermal expansion.
4. Damage to components from fluctuations in electrical or water supply.
5. Normal maintenance service, including adjustments, fuel system cleaning, and clearing of obstructions.
6. Transportation to service center, field labor charges, or freight damage.

**WHAT YOU MUST DO TO OBTAIN WARRANTY SERVICE**

In order to obtain warranty service on items warranted by Hotsy, you must return the product to your Authorized Hotsy Distributor, freight prepaid, with proof of purchase, within the applicable warranty period. If the product is permanently installed, you must notify your Authorized Hotsy Distributor of the defect. Your Authorized Hotsy Distributor will file a claim with Hotsy, who must subsequently verify the defect. In most cases, the part must be returned to Hotsy freight prepaid with the claim. For warranty service on components warranted by other manufacturer's, your Authorized Hotsy Distributor can help you obtain warranty service through these manufacturers' local authorized service centers.

**LIMITATION OF LIABILITY**

Hotsy's liability for special, incidental, or consequential damages is expressly disclaimed. In no event shall Hotsy's liability exceed the purchase price of the product in question. Hotsy makes every effort to ensure that all illustrations and specifications are correct, however, these do not imply a warranty that the product is merchantable or fit for a particular purpose, or that the product will actually conform to the illustrations and specifications. Our obligation under this warranty is expressly limited at our option to the replacement or repair at a service facility or factory designated by us, of such part or parts as inspection shall disclose to have been defective. **THE WARRANTY CONTAINED HEREIN IS IN LIEU OF ALL OTHER WARRANTIES, EXPRESS OR IMPLIED, INCLUDING ANY IMPLIED WARRANTY OF MERCHANTABILITY OR FITNESS FOR A PARTICULAR PURPOSE ARE EXPRESSLY LIMITED TO THE DURATION OF THIS WRITTEN WARRANTY.** Hotsy does not authorize any other party, including authorized Hotsy Distributors, to make any representation or promise on behalf of Hotsy, or to modify the terms, conditions, or limitations in any way. It is the buyer's responsibility to ensure that the installation and use of Hotsy products conforms to local codes. While Hotsy attempts to assure that its products meet national codes, it cannot be responsible for how the customer chooses to use or install the product. Some states do not allow limitations on how long an implied warranty lasts or the exclusion or limitation of incidental or consequential damages, so the above limitation or exclusion may not apply to you. This warranty gives you specific legal rights and you may also have other rights which vary from state to state.

**HOTSY**

[www.hotsy.com](http://www.hotsy.com)



---

If you are looking for replacement parts for your Hotsy, please contact your local dealer. You can find a dealer by calling Hotsy at 800-525-1976 or by visiting [www.hotsy.com](http://www.hotsy.com).

---

If you need service on your pressure washer, contact your local Hotsy dealer or visit [www.Hotsy.com](http://www.Hotsy.com). Smart phone users scan the code below to link directly to the Service Request page.

